

# PRODUCT DATA DRAWING

REVISION HISTORY			
REV	DESCRIPTION	DATE	APPROVED
A	DCN 54597	6/24	SEE PDM

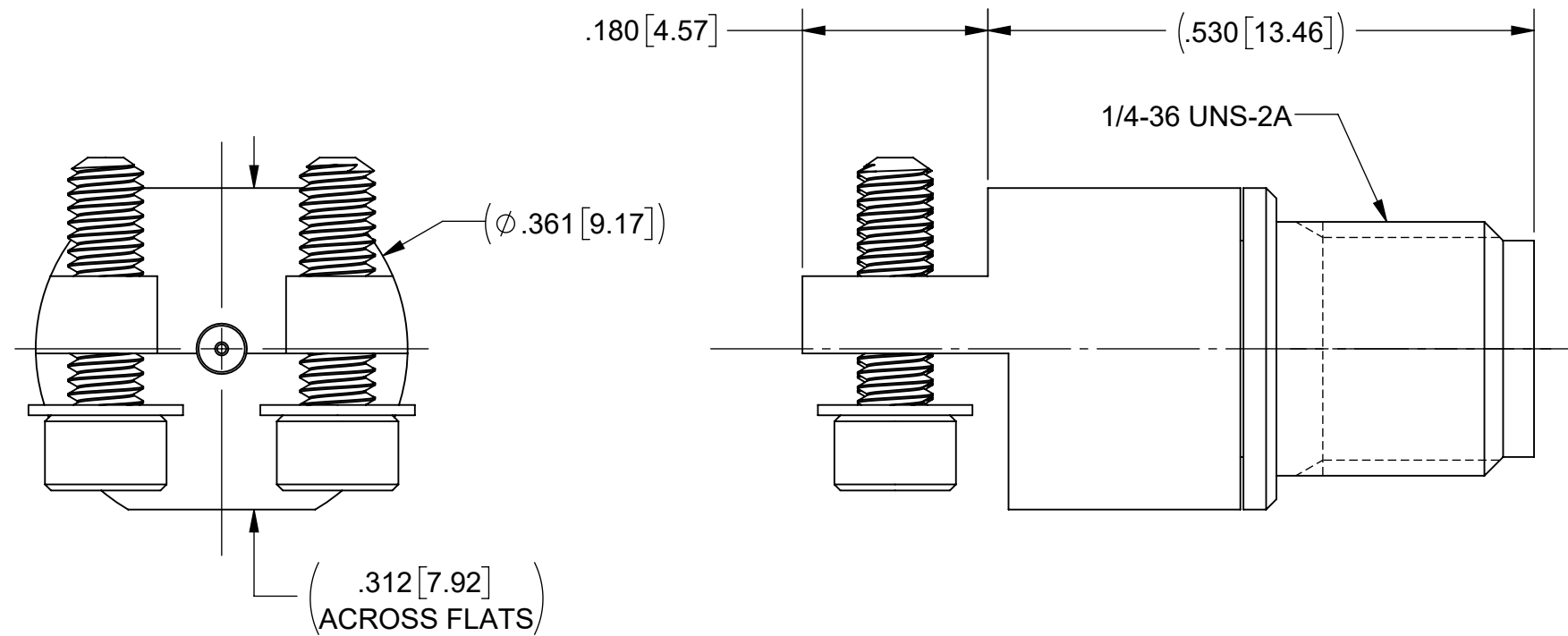
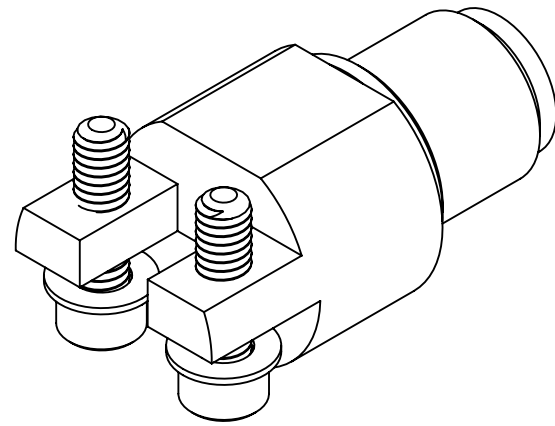

## MATERIAL:

**BODIES & INSERT:** STAINLESS STEEL PER AMS 5640, ALLOY UNS S30300, TYPE 1 OR ASTM A582 TYPE 303, CONDITION A.

**CONTACT:** BERYLLIUM COPPER PER ASTM B196, ALLOY No. UNS C17300, TD04.

**PIN:** KOVAR PER ASTM-F15

**GLASS:** CORNING 7070

**BEAD:** ULTEM 1000

**SCREWS AND WASHERS:** 18-8 STAINLESS STEEL

## FINISH:

**BODIES, CONTACT & PIN:** GOLD PER ASTM B488, TYPE II, CODE C, CLASS 1.27, OVER NICKEL PER AMS-QQ-N-290, CLASS 1, .00005" MIN.

**INSERT:** PASSIVATED PER AMS 2700

## PERFORMANCE:

**IMPEDANCE:** 50 OHMS  
**FREQ. RANGE:** DC TO 40.0 GHz.

## NOTES:

1. MOUNTING SCREWS INTENDED FOR USE AS A SOLDER REFLOW FIXTURING AID.

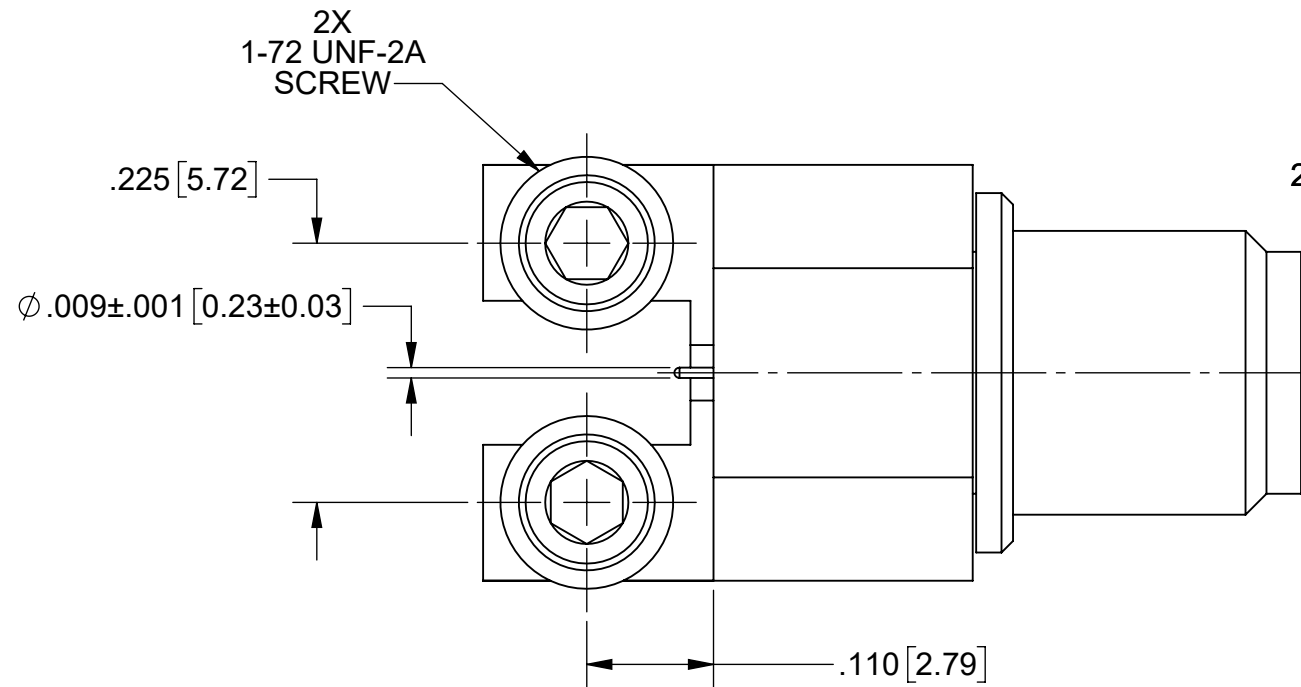

## RECOMMENDED MOUNTING PATTERN

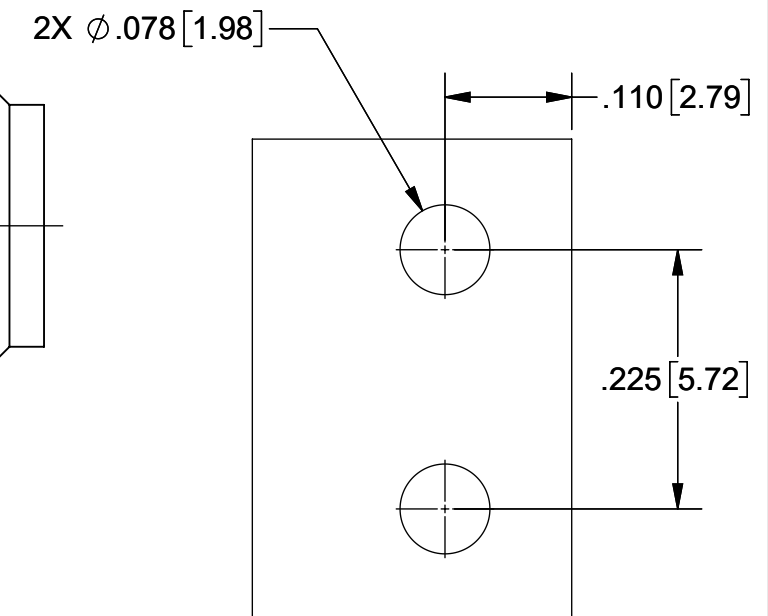

MATERIAL: SEE NOTES	DIMENSIONS ARE IN INCHES TOLERANCES: FRACTIONAL: ±1/64 ANGULAR: X° ±1'0" X'X' ±15'	UNLESS OTHERWISE SPECIFIED 1) ALL DIMENSIONS ARE IN INCHES (MILLIMETERS) 2) ALL DIMENSIONS ARE AFTER PLATING. 3) BREAK CORNERS & EDGES .005 R. MAX. 4) CHAM. 1ST & LAST THREADS. 5) SURFACE ROUGHNESS 63-MIL-STD-10. 6) DIA.'S ON COMMON CENTERS TO BE CONCENTRIC WITHIN .005 T.I.R. 7) REMOVE ALL BURRS	 <b>TITLE:</b> 2.92mm F TORQUE RESISTANT EDGE LAUNCH CONNECTOR
FINISH: SEE NOTES	DECIMAL: X ±.030 .XX ±.010 .XXX ±.005	INTERPRET DIMENSIONS AND TOLERANCES PER ASME Y14.5M - 1994	
SURFACE AREA: N/A	THIRD ANGLE PROJECTION	DRAWN: JPM 6/12/24	SIZE DWG. NO. 1521-60235
<b>PROPRIETARY</b> THE INFORMATION CONTAINED IN THIS DRAWING IS THE SOLE PROPERTY OF SV MICROWAVE, INC. ANY REPRODUCTION IN PART OR AS A WHOLE WITHOUT THE WRITTEN PERMISSION OF SV MICROWAVE, INC IS PROHIBITED.		CHECKED: SEE PDM	SCALE: 6:1
		APPROVED: SEE PDM	SHEET 1 OF 1