

REVISION HISTORY			
REV	DESCRIPTION	DATE	APPROVED
-	NRN 38670	03/14	STW

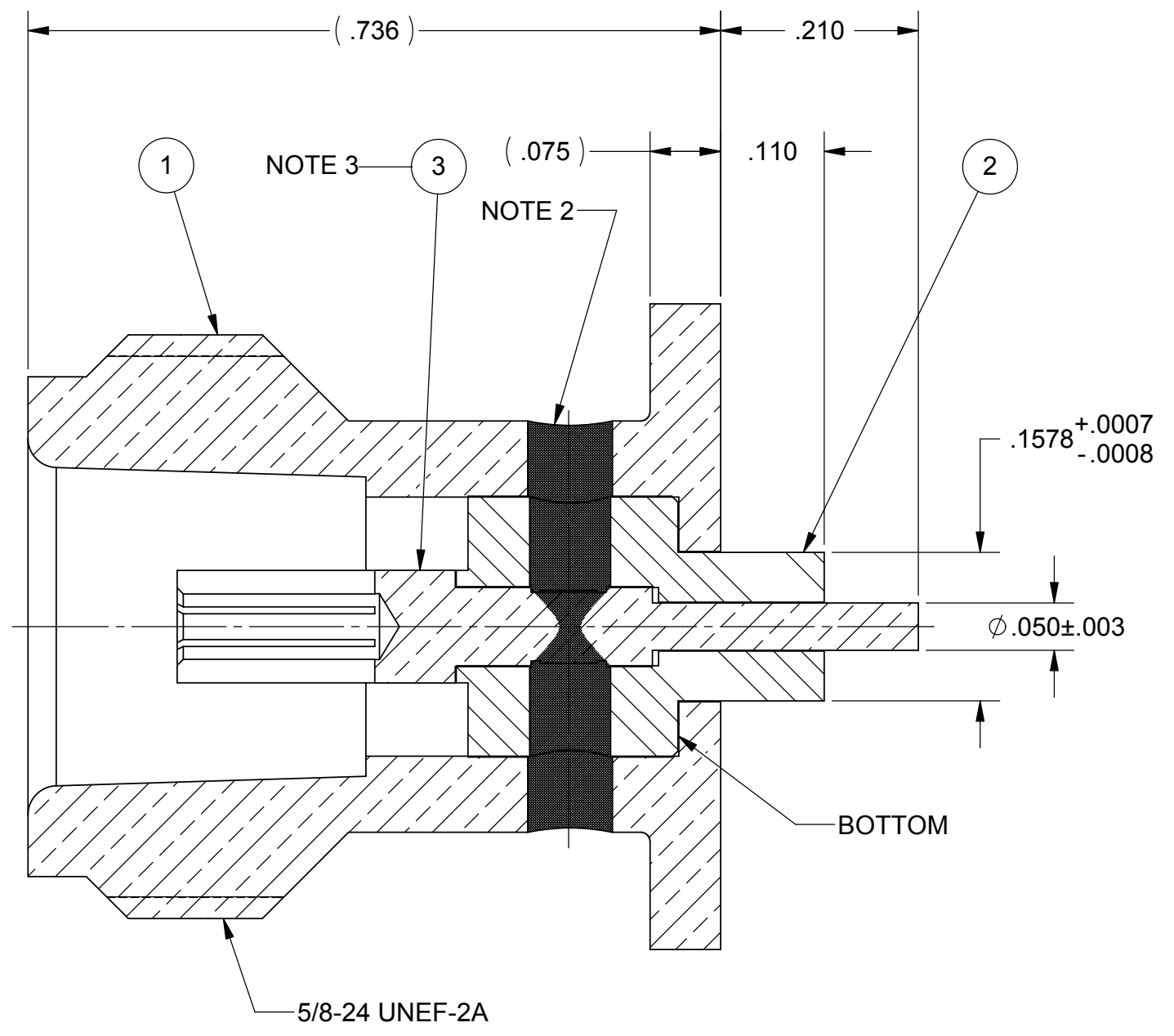

SECTION A-A

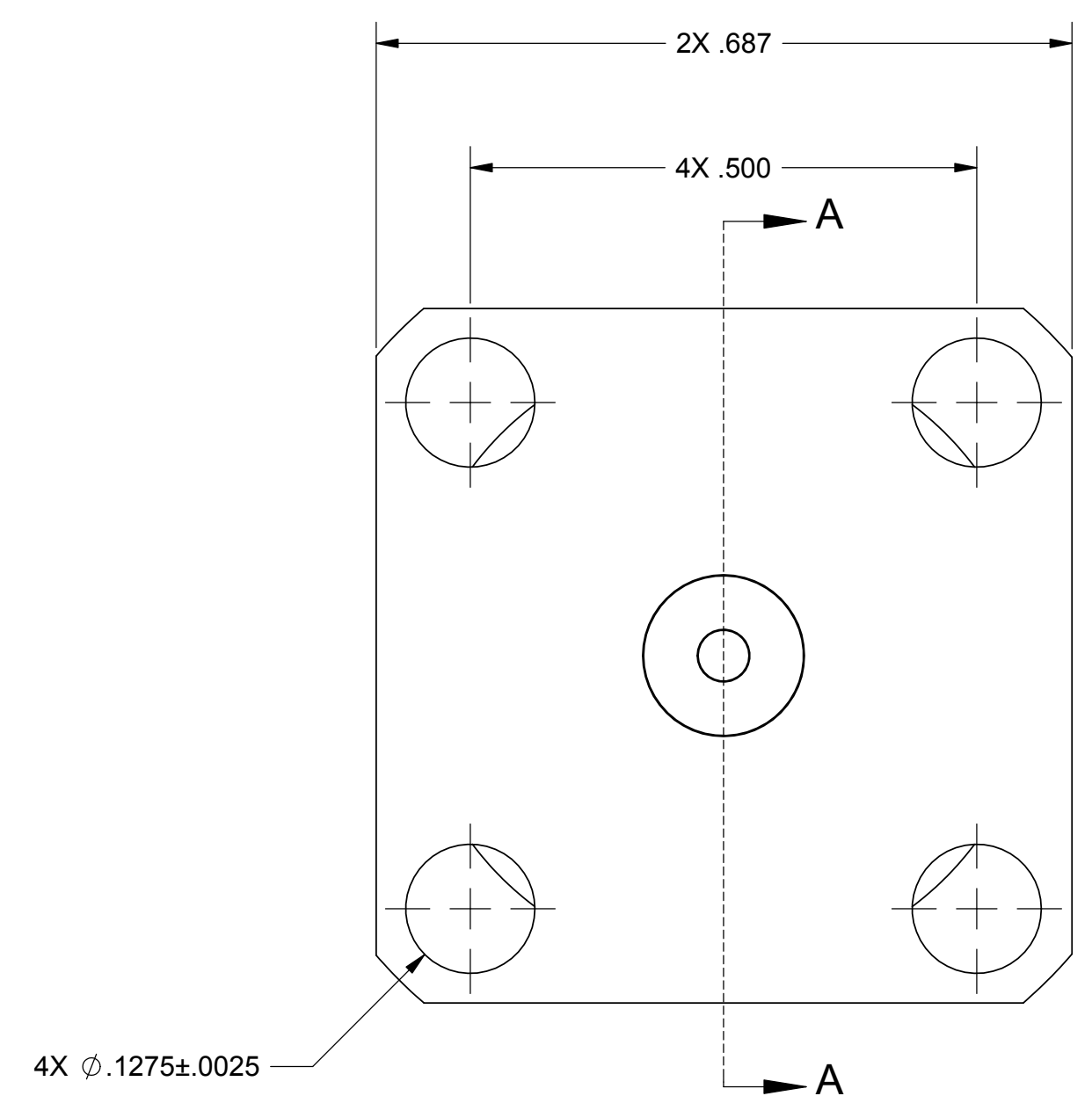

MATERIAL: PER BOM	DIMENSIONS ARE IN INCHES TOLERANCES:	UNLESS OTHERWISE SPECIFIED 1) ALL DIMENSIONS ARE AFTER PLATING. 2) BREAK CORNERS & EDGES .005 R. MAX. 3) CHAM. 1ST & LAST THREADS. 4) SURFACE ROUGHNESS 63 / MIL-STD-10. 5) DIA.'S ON COMMON CENTERS TO BE CONCENTRIC WITHIN .005 T.I.R. 6) REMOVE ALL BURRS	SV Microwave, Inc. 2400 Centrepark West Drive, Suite 100 West Palm Beach, FL 33409
FINISH: PER BOM	FRACTIONAL: ±1/64 ANGULAR: X° ±1'0" X'X' ±15'		
PROPRIETARY THE INFORMATION CONTAINED IN THIS DRAWING IS THE SOLE PROPERTY OF SV MICROWAVE, INC. ANY REPRODUCTION IN PART OR AS A WHOLE WITHOUT THE WRITTEN PERMISSION OF SV MICROWAVE, INC IS PROHIBITED.	DECIMAL: X ±.030 .XX ±.010 .XXX ±.005	DRAWN: BNK 03/20/14	TITLE: TYPE N JACK PANEL RECEPTACLE
	INTERPRET DIMENSIONS AND TOLERANCES PER ASME Y14.5M - 1994	THIRD ANGLE PROJECTION	CHECKED: STW 03/20/14
		APPROVED: STW 03/20/14	SCALE: 6:1
		E.M. SIMULATION: N/A	SHEET 1 OF 2