

NOTES:

1. MATERIALS AND FINISHES:
 - BODY - ZINC DIECAST, NICKEL PLATING
 - CONTACT - PHOSPHOR BRONZE, GOLD PLATING
 - INSULATOR - DELRIN, NATURAL
 - LOCK WASHER & SOLDER TAG - BRASS, NICKEL PLATING
 - HEX NUT - STAINLESS STEEL, NICKEL PLATING
2. ELECTRICAL:
 - A. IMPEDANCE: 50 OHM
 - B. DIELECTRIC WITHSTANDING VOLTAGE: 1000 VRMS, MIN.
3. MECHANICAL:
 - A. DURABILITY: 500 CYCLES, MIN.
 - B. TEMPERATURE RANGE: -40°C TO +85°C
4. MAX. PANEL THICKNESS IS 3.3 [.130]
5. PACKAGING:
 - A. QUANTITY: SINGLE PACK
 - B. BAG TO BE MARKED: AMPHENOL RF
31-221-RFX
B6351D4-ND3G-50
DATE CODE

THIRD ANGLE PROJ.

REVISIONS

REV	DESCRIPTION	DATE	ECO	APPR
A	RELEASE TO MFG.	5/3/91	38063	DR
B	UPDATE HEX NUT PART PLATING SPEC.	13-Feb-15	-----	SH
H	SEE SHEET 1	11/24/00	43339	CPM
J	SYNC, UPDATE THE DRAWING FORMAT \RD-DMI6052501S2	13-Apr-16	00884	SH
K	ADD PACKAGING INFORMATION IN NOTE 5 \RD-DMI7021601S2	25-Oct-16	03103	KEN
L	HEX NUT MATERIAL WAS CHANGED	31-Aug-18	-----	KCE

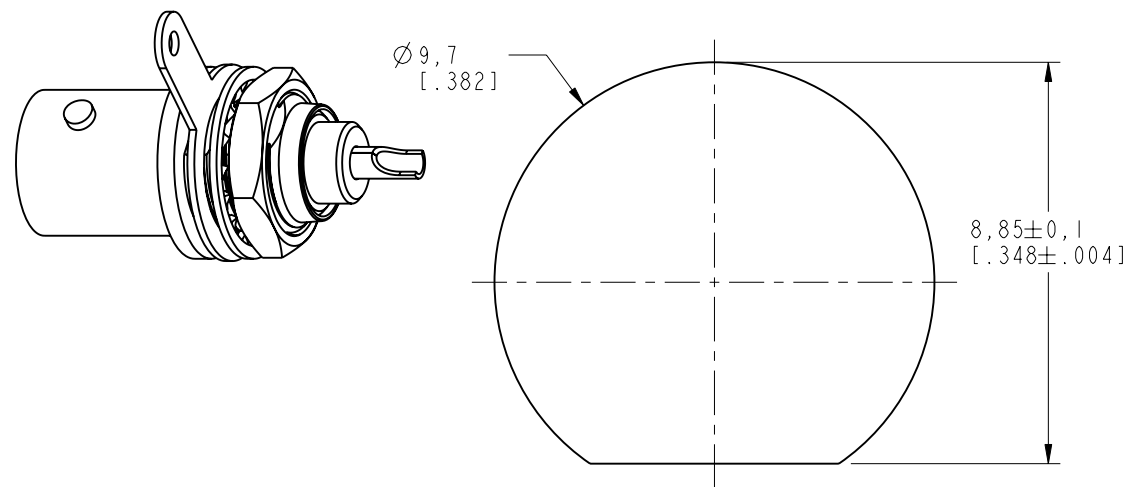

RECOMMENDED MOUNTING HOLE

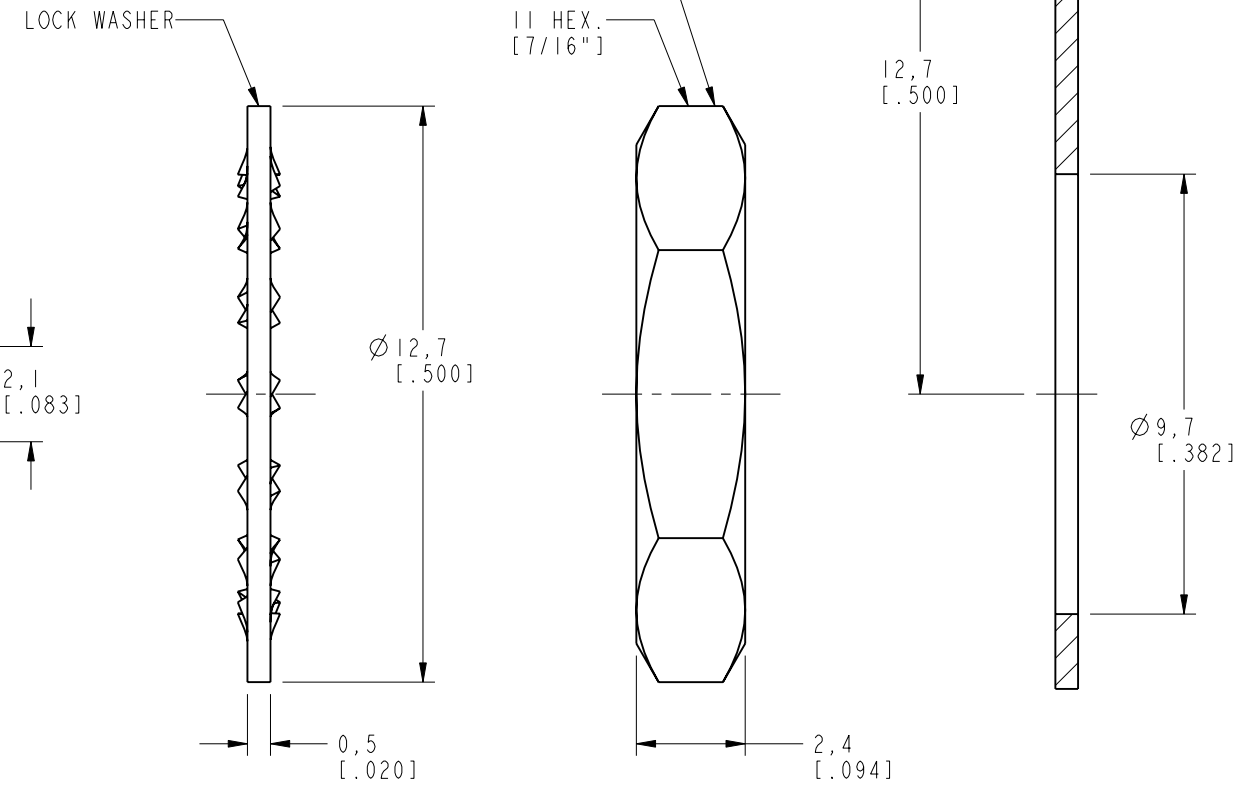
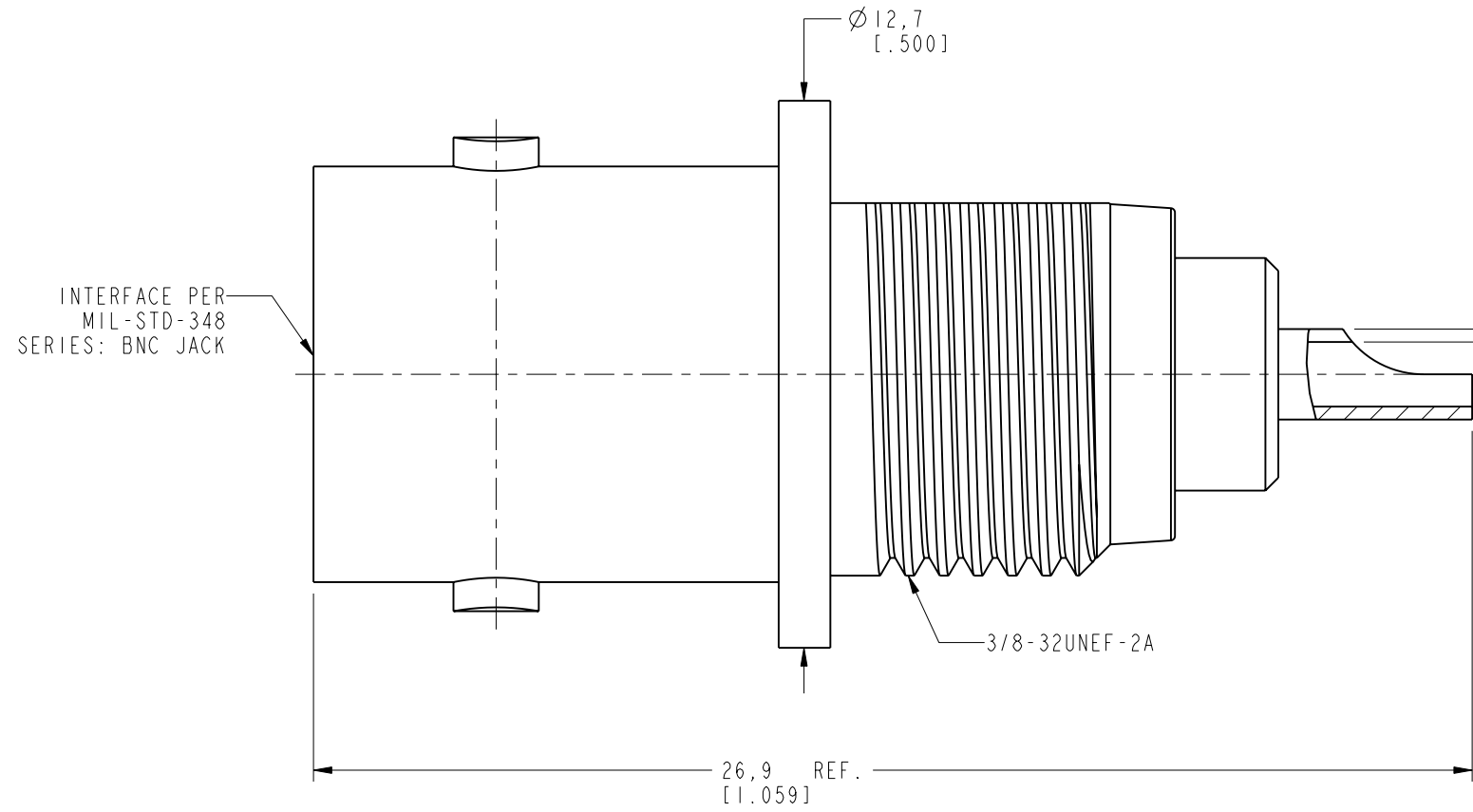

CUSTOMER OUTLINE DRAWING
ALL OTHER SHEETS ARE FOR INTERNAL USE ONLY

UNLESS OTHERWISE SPECIFIED, DIMENSIONS ARE IN METRIC AND TOLERANCES ARE: <0.5mm ±0.05mm 0.5 - 6mm ±0.1mm 6 - 30mm ±0.2mm 30 - 120mm ±0.3mm ANGLES ±1°	MATERIAL	DRAWN	DATE	TITLE BNC BULKHEAD RECEPTACLE JACK	Amphenol RF www.amphenolrf.com
	SEE NOTES	S. DUAN	31-Aug-18		
NOTICE - These drawings, specifications, or other data (1) are, and remain the property of Amphenol corp. (2) must be returned upon request; and (3) are confidential and not to be disclosed to any person other than those to whom they are given by Amphenol Corp. the furnishing of these drawings, specifications, or other data by Amphenol Corp., or to any other person to anyone for any purpose is not to be regarded by implication or otherwise in any manner licensing, granting rights to permitting such holder or any other person to manufacture, use or sell any product, process or design, patented or otherwise, that may in any way be related to or disclosed by said drawings, specifications, or other data.	REFERENCE AND CONFIGURATION LEVEL: In Work	ENGINEER	DATE	SCALE: 4.0:1.0	SHEET 2 OF 3
	FINISH	S. HSIEH	08-Sep-06	DWG SIZE	REV
			APPROVED	DATE	B
		S. HSIEH	31-Aug-18		
		CAD FILE			
					DRAWING NO. B6351D4-ND3G-50
					ITEM NO. 016351AAF0IND5F
					PART NO. 31-221-RFX