

# RIGHT ANGLE PLUG CRIMP ATTACHMENTS FOR FLEXIBLE CABLE

For Cable Group Legend, see page 69

## RIGHT ANGLE SOLDER PLUG — SEMI-RIGID CABLE

P.N.	Cable Group	Finish	Insulation	Impedance	Crimp Tool
112617	10	Nickel/Gold	Teflon	50	N/A
112614	11	Nickel/Gold	Teflon	50	N/A

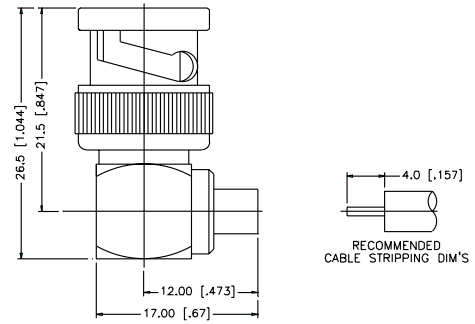

## RIGHT ANGLE CRIMP/CRIMP PLUG — STANDARD CABLE

P.N.	Cable Group	Finish	Insulation	Impedance	Crimp Tool
Brass Shell					
112182	01	Nickel	Delrin	50	A
112184	03	Nickel	Delrin	50	A
112185	03	Nickel	Delrin	75	A
112540	08	Nickel	Teflon	75	E
112539	15	Nickel	Teflon	75	A
Diecast Shell					
112186	01	Nickel	Delrin	50	A
112189	03	Nickel	Delrin	75	A

Remark: Crimp/Crimp Type

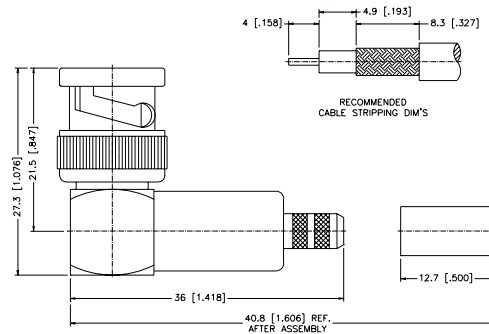

## RIGHT ANGLE CRIMP/CRIMP PLUG — PLENUM CABLE

P.N.	Cable Group	Finish	Insulation	Impedance	Crimp Tool
Brass Shell					
112190	02	Nickel	Delrin	50	A
112193	04	Nickel	Delrin	75	A
Diecast Shell					
112194	02	Nickel	Delrin	50	A
112197	04	Nickel	Delrin	75	A

Remark: Crimp/Crimp Type

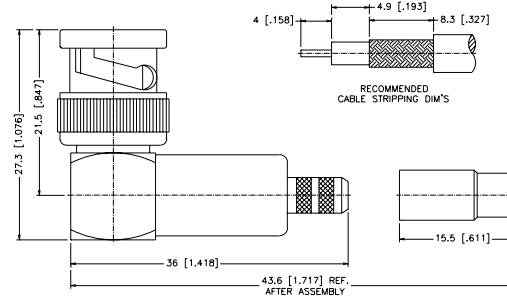
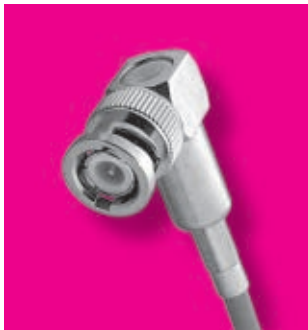

## RIGHT ANGLE CRIMP/CRIMP PLUG — MINIATURE CABLE

P.N.	Cable Group	Finish	Insulation	Impedance	Crimp Tool
Brass Shell					
112198	05	Nickel	Delrin	50	B
112199	06	Nickel	Delrin	75	B
Diecast Shell					
112200	05	Nickel	Delrin	50	B
112201	06	Nickel	Delrin	75	B

Remark: With teflon sleeve Hex. crimp size .178" Crimp/Crimp Type

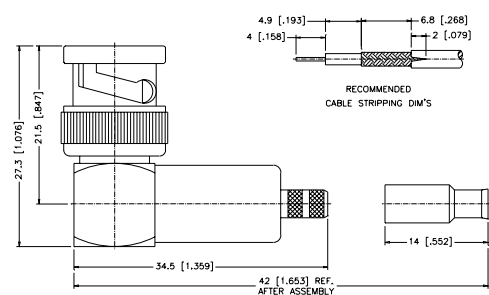

For Reverse Polarized connectors, add RP to standard part number. Contact Connex marketing for availability. For Crimp Tool information, see page 183.

