

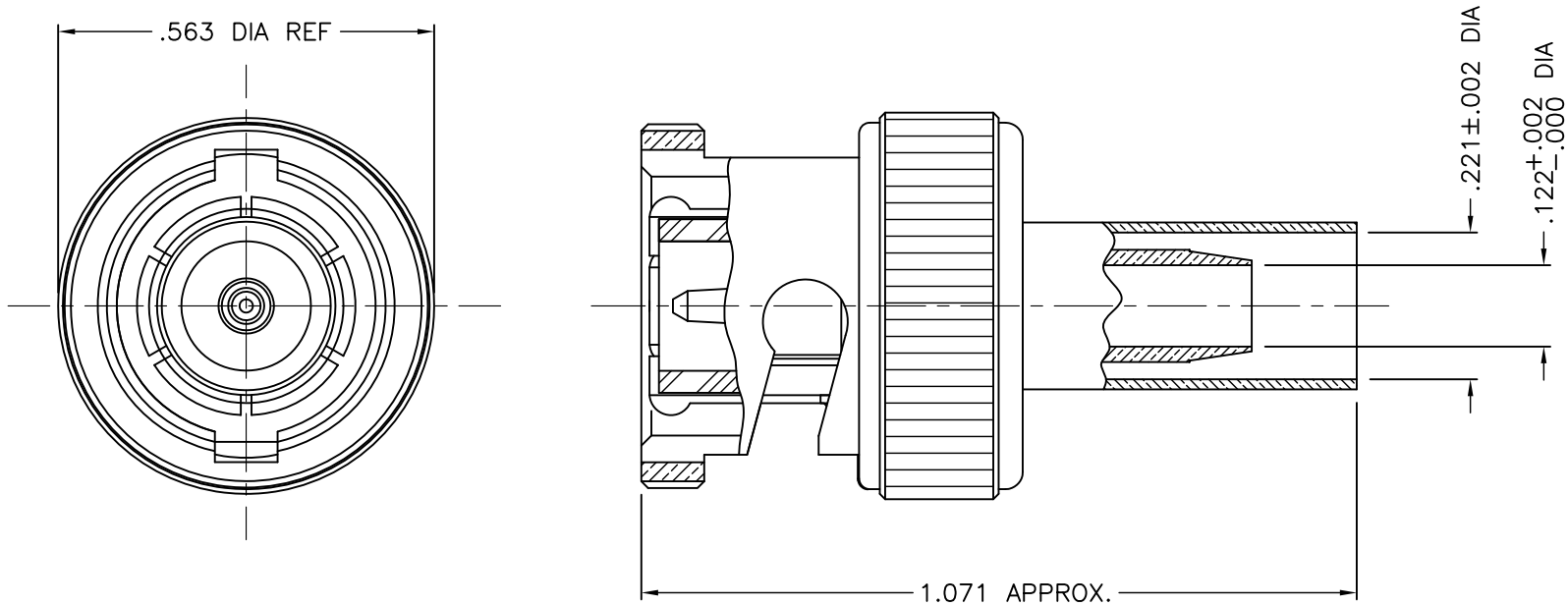

1003-013-A00E-2



NOTES:

1. ASSEMBLED CONNECTOR INTERFACE IS DESIGNED IN ACCORDANCE WITH MIL-STD-348.
2. MATERIAL: SPRING WASHER - BERYLLIUM COPPER PER ASTM B196.
 INSULATOR - TEFLON PER ASTM D1710
 GASKET - SILICONE RUBBER PER ZZ-R-765
 CRIMP SLEEVE - D.H.P. COPPER CDA ALLOY 122
 ALL OTHER METAL PARTS - BRASS PER ASTM B16
3. FINISHES: CONTACT - GOLD PLATE PER MIL-G-45204
 SPRING WASHER - NICKEL PLATE PER QQ-N-290
 ALL OTHER METAL PARTS - SILVER PLATE PER QQ-S-365

M39012/16-0014

DELTA ELECTRONICS MFG. CORP. Beverly, MA 01915				
TITLE: BNC CRIMP PLUG FOR RG-55, 142, 223, & 400/U CABLES - CAPTIVE CONTACT				
Drawn by BJM	Scale 4/1	Ckd. by MR	Engr Appd MR	FILE NAME: 1003013A00E-002T
5/27/09				
CODE IDENT.-00795		1003-013-A00E-2		

UNLESS OTHERWISE SPECIFIED: TOLERANCES: 3 PLACES = ±.005, 2 PLACES = ±.02, ANGLES = ±1/2'	-	OUTLINE	5/27/09
	ALT.	REVISIONS	DATE

THESE DRAWINGS AND SPECIFICATIONS ARE THE PROPERTY OF DELTA ELECTRONICS MFG CORP. AND SHALL NOT BE REPRODUCED, OR COPIED OR USED AS THE BASIS FOR THE MANUFACTURE OR SALE OF APPARATUS OR DEVICES WITHOUT THEIR EXPRESS WRITTEN CONSENT.