

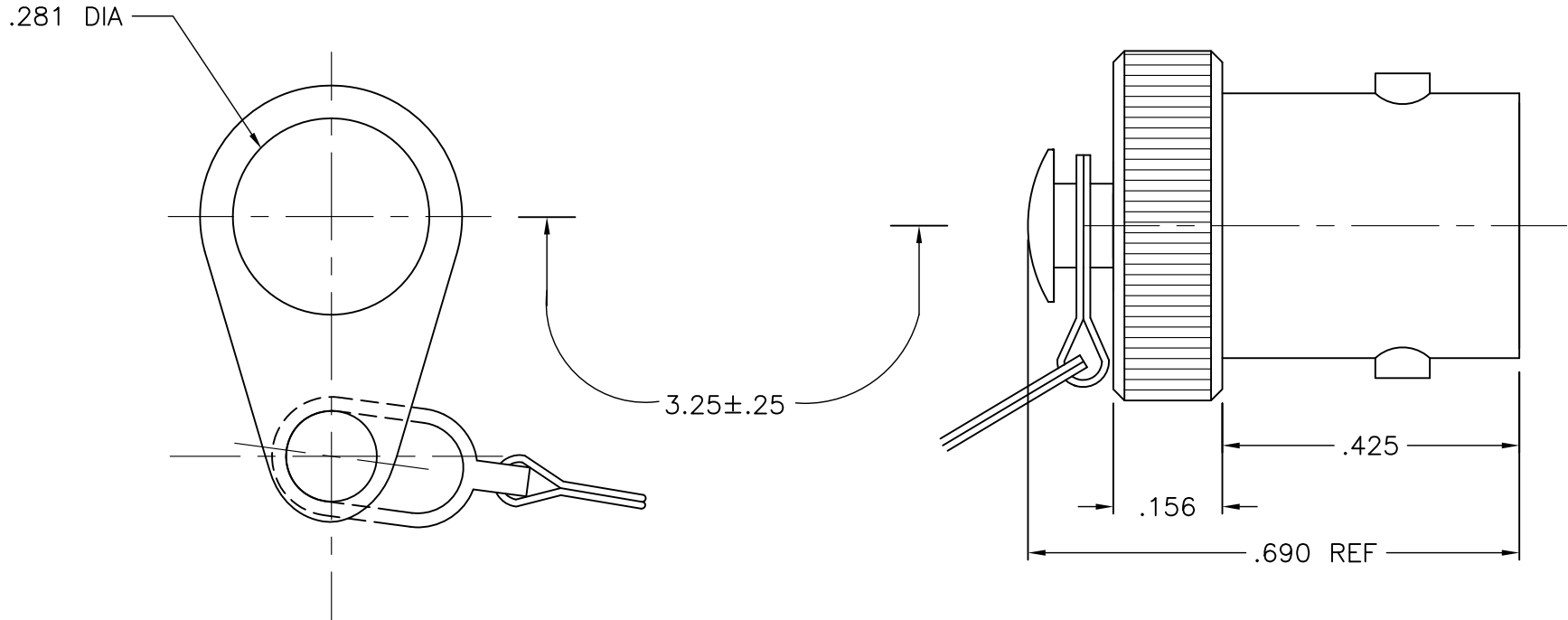

1033-000-A00B



**NOTES:**

1. MATERIAL: LUG - CORROSION RESISTANT STEEL PER ASTM A582  
 BODY AND RIVETS - BRASS PER ASTM B16  
 CHAIN - STAINLESS STEEL
2. FINISHES: BODY - SILVER PLATE PER QQ-S-365  
 RIVETS - NICKEL PLATE PER QQ-N-290  
 CHAIN AND LUG - PASSIVATE PER QQ-P-35

M39012/25-0009

UNLESS OTHERWISE SPECIFIED: TOLERANCES: 3 PLACES = ±.005, 2 PLACES = ±.02, ANGLES = ±1/2°, SURFACE FINISH = 63

-	OUTLINE	10/24/03
ALT.	REVISIONS	DATE

DELTA ELECTRONICS MFG. CORP. Beverly, MA 01915

TITLE: DUST CAP FOR BNC PLUG  
 - WITH SAFETY CHAIN

Drawn by BJM 10/24/03	Scale 4/1	Ckd. by MR	Engr Appd MR	FILE NAME: 1033000A00B-000T
-----------------------------	--------------	---------------	-----------------	--------------------------------

CODE IDENT.-00795 1033-000-A00B

THESE DRAWINGS AND SPECIFICATIONS ARE THE PROPERTY OF DELTA ELECTRONICS MFG CORP. AND SHALL NOT BE REPRODUCED, OR COPIED OR USED AS THE BASIS FOR THE MANUFACTURE OR SALE OF APPARATUS OR DEVICES WITHOUT THEIR EXPRESS WRITTEN CONSENT.