

1101-031-N003-3

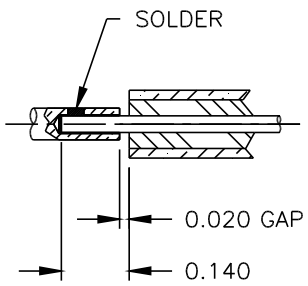

RECOMMENDED CABLE TRIMMING INSTRUCTIONS

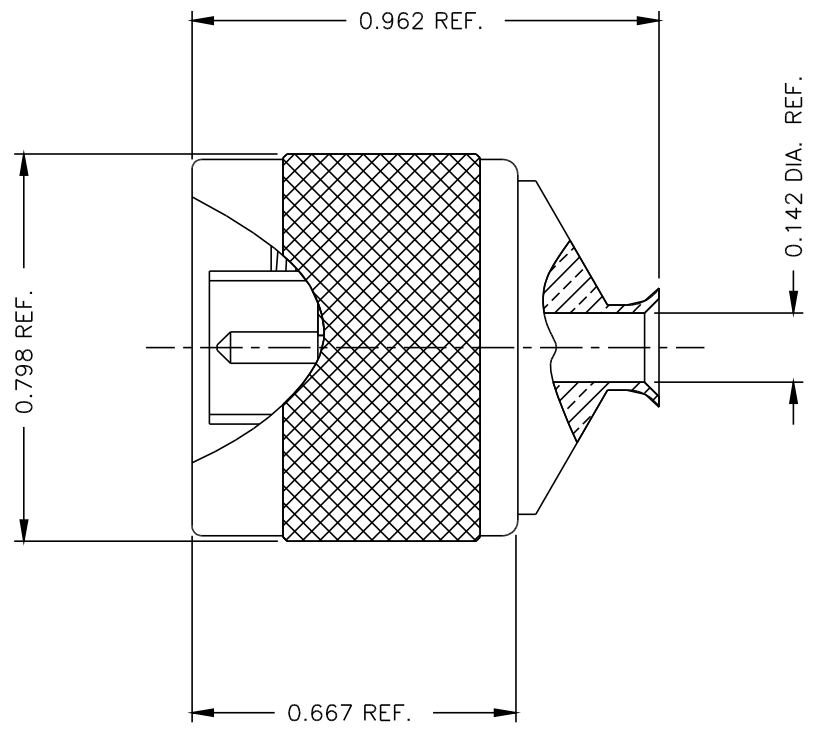

DELTA ELECTRONICS MFG. CORP. Beverly, MA 01915			
TITLE SERIES "N" (M) PLUG FOR (.141 DIA.) SEMI RIGID CABLE			
MATERIAL BRASS			
FINISH NUT		BODY & CONTACT	
NICKEL		GOLD	
Drawn by	Scale	Ckd. by	Mfg. Appd.
nct	4/1		
11-8-93			
Engr. Appd.		Engr. Appd.	
Alt. Revisions		Date	FILE NAME: 1101031N003-003T PLT @ 4/1
11-8-93			
ENGR APPD		MFG APPD	
CODE IDENT.-00795		1101-031-N003-3	

LB./M	FT./M	Stock Size
TOLERANCES: UNLESS OTHERWISE SPECIFIED; DECIMALS = ±.005, FRACTIONS = ±1/64, ANGLES = ±1/2° REMOVE ALL BURRS AND SHARP EDGES.		
THESE DRAWINGS AND SPECIFICATIONS ARE THE PROPERTY OF DELTA ELECTRONICS MFG. CORP. AND SHALL NOT BE REPRODUCED, OR COPIED, OR USED AS THE BASIS FOR THE MANUFACTURE OR SALE OF APPARATUS OR DEVICES WITHOUT THEIR EXPRESS WRITTEN CONSENT.		