

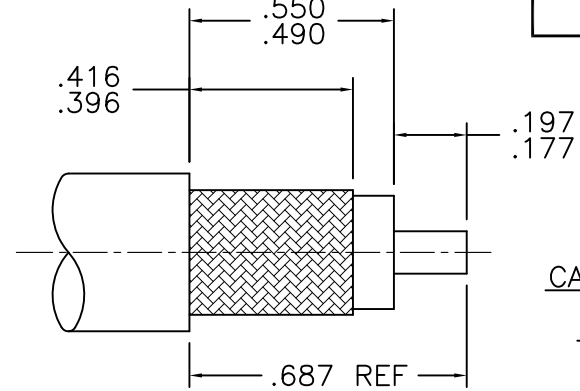

1119018A72E-000

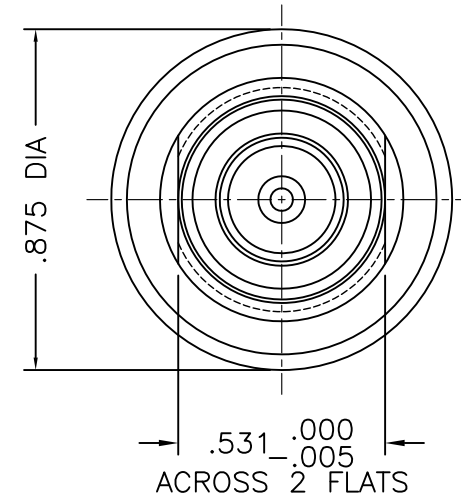

CABLE TRIMMING
DIMENSIONS

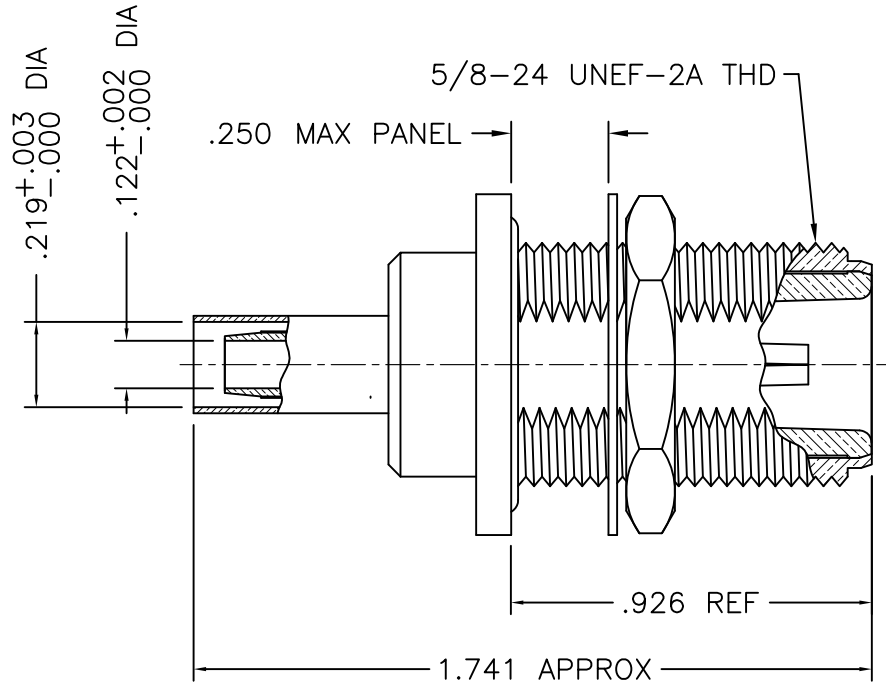

NOTES:

1. ASSEMBLED CONNECTOR INTERFACE IS DESIGNED IN ACCORDANCE WITH MIL-STD-348.
2. MATERIAL: BODY & HEX NUT- BRASS PER ASTM B16
 LOCKWASHER- SPRING STEEL
 CONTACT- PHOSPHOR BRONZE PER QQ-B-750
 BUSHING- BRASS PER ASTM B16.
 GASKET- SILICONE RUBBER PER ZZ-R-765
 INSULATOR- TEFLON PER ASTM D1710
 CRIMP SLEEVE- D.H.P. COPPER CDA ALLOY 122
3. FINISHES: CONTACT- GOLD PLATE PER MIL-G-45204
 ALL OTHER METAL PARTS- SILVER PLATE PER QQ-S-365

M39012/03-0503

C	REVISED	5/9/13
B	REDRAWN	5/13/97
ALT.	REVISIONS	DATE

DELTA ELECTRONICS MFG. CORP. Beverly, MA 01915

TITLE: 'N' (F) SHORT CRIMP BULKHEAD MOUNT
 JACK FOR RG-142/U CABLE

TOLERANCES UNLESS OTHERWISE SPECIFIED: 3 PLACES = ±.005 2 PLACES = ±.01 ANGLES = ±1/2°	Drawn by RWP 11/26/96	Scale 2/1	Ckd. by	FILE NAME: 1119018A72E-000T
---	-----------------------------	--------------	---------	--------------------------------

CODE IDENT.-00795

1119018A72E-000