

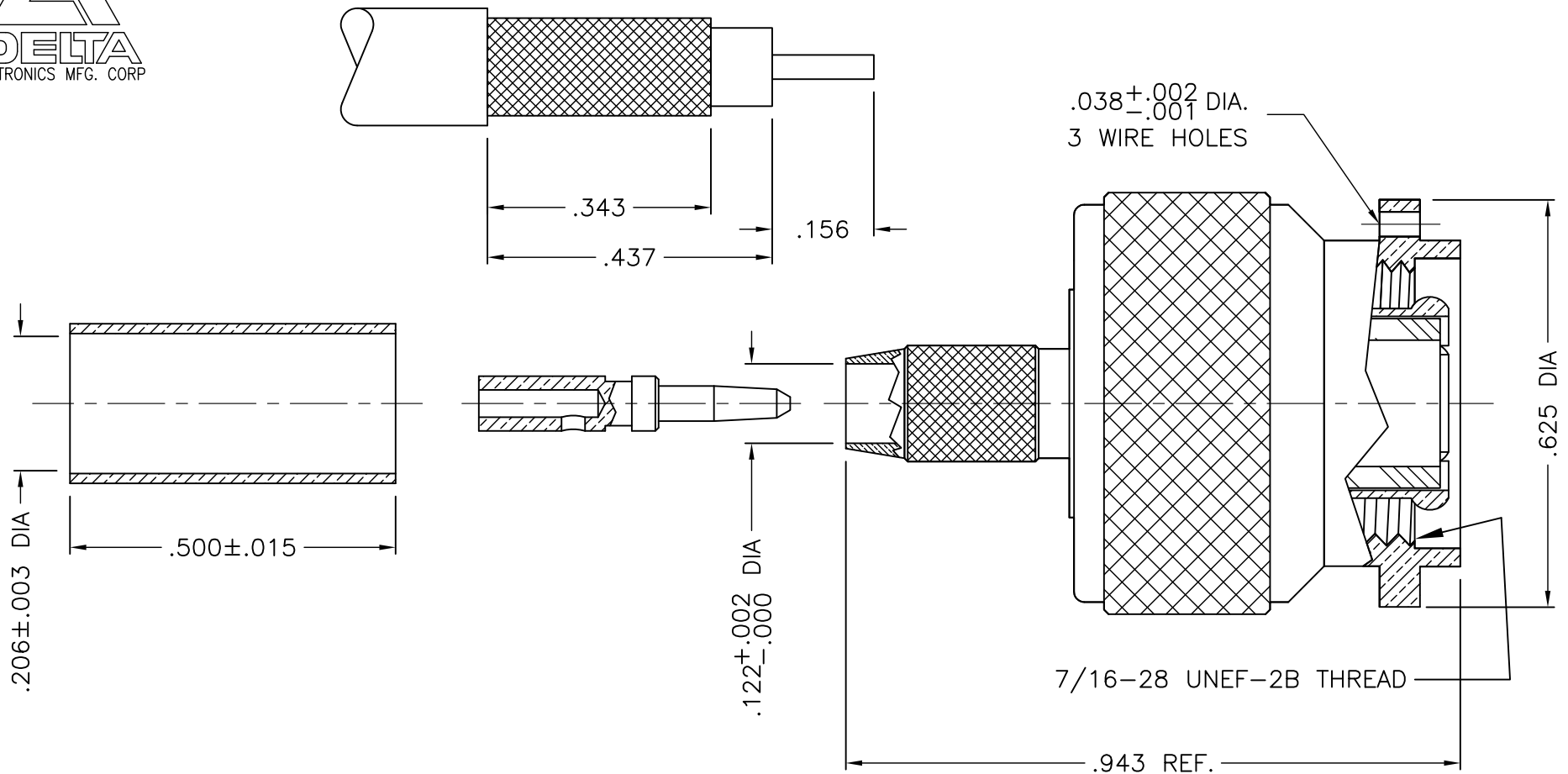

RECOMMENDED CABLE TRIM DIMENSIONS

1203-017-A00E-2



NOTES:

1. ASSEMBLED CONNECTOR INTERFACE IS DESIGNED IN ACCORDANCE WITH MIL-STD-348.
2. MATERIAL: BODY & CONTACT - BRASS PER ASTM B16
 CONTACT FINGERS - BERYLLIUM COPPER PER B196
 GASKET - SILICONE RUBBER PER A-A-59588
 INSULATOR - TEFLON PER ASTM D1710
 CRIMP SLEEVE - D.H.P. COPPER CDA ALLOY 122
3. FINISHES: RETAINING RING - NOT PLATED
 CONTACT - GOLD PLATE PER ASTM B488
 ALL OTHER METAL PARTS - SILVER PLATE PER QQ-S-365

M39012/26-0010

DELTA ELECTRONICS MFG. CORP. Beverly, MA 01915

TITLE: "TNC" CRIMP PLUG FOR RG-58 & 303/U CABLE - CAPTIVE CONTACT

UNLESS OTHERWISE SPECIFIED: TOLERANCES: 3 PLACES = ±.005, 2 PLACES = ±.02, ANGLES = ±1/2°

-	OUTLINE	10/28/09
ALT.	REVISIONS	DATE

Drawn by ADK 10/28/09	Scale 4/1	Ckd. by MR	Engr Appd MCD	FILE NAME: 1203017N00E-001T
-----------------------------	--------------	---------------	------------------	--------------------------------

CODE IDENT.-00795

1203-017-A00E-2

THESE DRAWINGS AND SPECIFICATIONS ARE THE PROPERTY OF DELTA ELECTRONICS MFG CORP. AND SHALL NOT BE REPRODUCED, OR COPIED OR USED AS THE BASIS FOR THE MANUFACTURE OR SALE OF APPARATUS OR DEVICES WITHOUT THEIR EXPRESS WRITTEN CONSENT.