

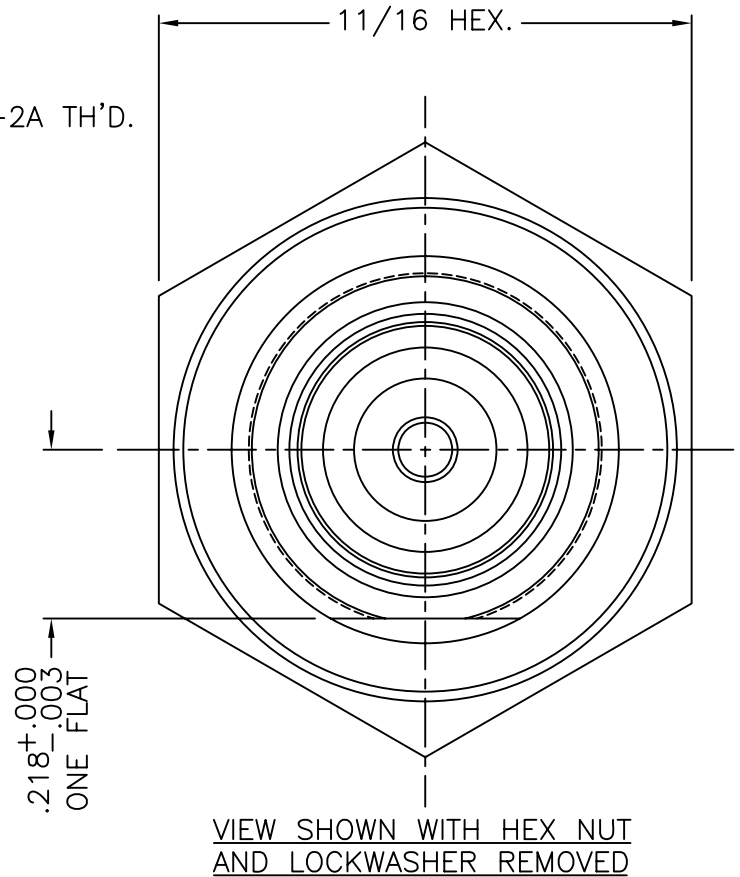

1216-015-A59E-1

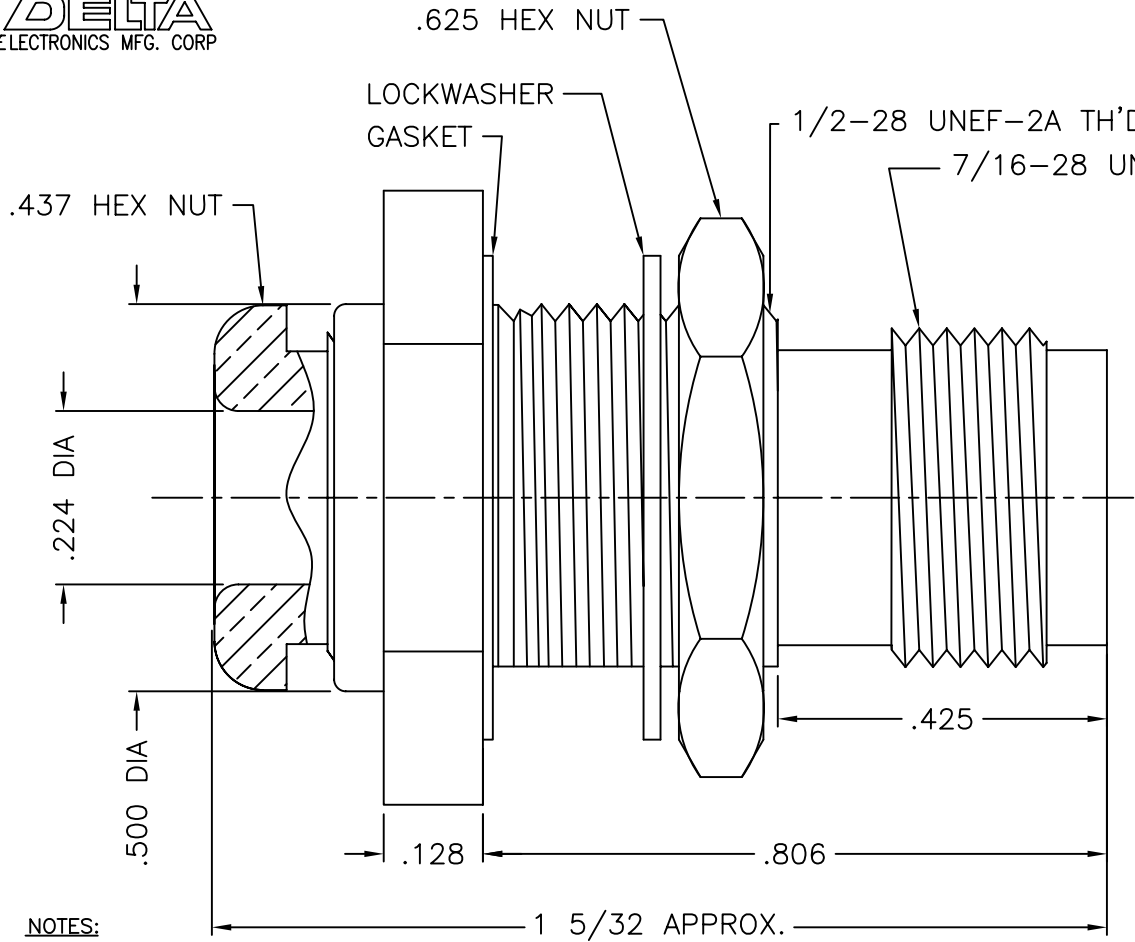

- NOTES:
1. ASSEMBLED CONNECTOR INTERFACE IS DESIGNED IN ACCORDANCE WITH MIL-STD-348.
 2. MATERIAL: CONTACT - BERYLLIUM COPPER PER ASTM B196.
 LOCKWASHER - SPRING STEEL
 INSULATORS - TEFLON PER ASTM D4894
 GASKETS - SILICONE RUBBER PER A-A-59588
 ALL OTHER METAL PARTS - BRASS PER ASTM B16
 3. FINISHES: CONTACT - GOLD PLATE PER ASTM B488
 4. RECOMMENDED TORQUE VALUES: CLAMP NUT - 12 to 15 in-lbs
 PANEL HEX NUT - 35 to 40 in-lbs

M39012/28-0101

DELTA ELECTRONICS MFG. CORP. Beverly, MA 01915				
TITLE: "TNC" CAPTIVE CONTACT B'HEAD MOUNTING JACK CLAMP JACK FOR RG-55, 58, 142, 223/U CABLES				
Drawn by BJM	Scale 4/1	Ckd. by MR	Engr Appd MR	FILE NAME: 1216015A59E-001T
2/25/08				

UNLESS OTHERWISE SPECIFIED: TOLERANCES: 3 PLACES = ±.005, 2 PLACES = ±.02, ANGLES = ±1/2°, SURFACE FINISH = 63

-	OUTLINE	2/25/08
ALT.	REVISIONS	DATE

THESE DRAWINGS AND SPECIFICATIONS ARE THE PROPERTY OF DELTA ELECTRONICS MFG CORP. AND SHALL NOT BE REPRODUCED, OR COPIED OR USED AS THE BASIS FOR THE MANUFACTURE OR SALE OF APPARATUS OR DEVICES WITHOUT THEIR EXPRESS WRITTEN CONSENT.

CODE IDENT.-00795 1216-015-A59E-1