

1232-000-A00B

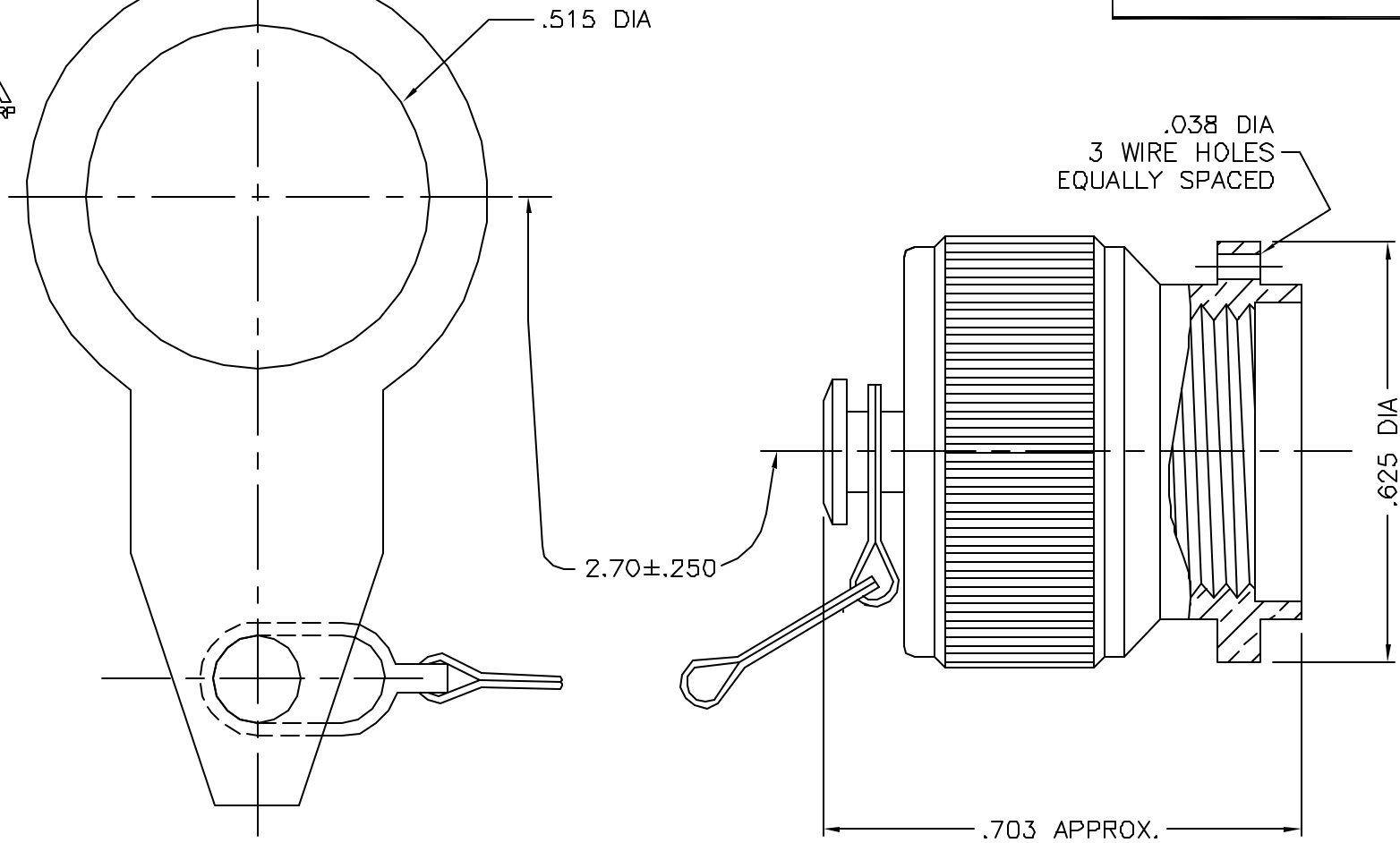

NOTES:

1. ASSEMBLED CONNECTOR INTERFACE IS DESIGNED IN ACCORDANCE WITH MIL-STD-348.
2. MATERIAL: CHAIN - CORROSION RESISTANT STEEL PER ASTM A582
LUG - SOFT COPPER PER QQ-C-576
GASKET - SILICONE RUBBER PER ZZ-R-765
ALL OTHER PARTS - BRASS PER ASTM B16.
3. FINISHES: LUG - NICKEL PLATE PER QQ-N-290
CHAIN - PASSIVATE PER QQ-P-35
ALL OTHER METAL PARTS - SILVER PLATE PER QQ-S-365

M39012/25-0021

DELTA ELECTRONICS MFG. CORP. Beverly, MA 01915

TITLE:
DUST CAP FOR TNC JACK W/SAFETY CHAIN

UNLESS OTHERWISE SPECIFIED: TOLERANCES: 3 PLACES = ±.003, 2 PLACES = ±.02, ANGLES = ±1/2°, SURFACE FINISH = 63	-	OUTLINE	12/3/02	Drawn by EJM	Scale 4/1	Ckd. by	Engr Appd	FILE NAME: 1232000A00B-000T
	ALT.	REVISIONS	DATE	12/3/02				

THESE DRAWINGS AND SPECIFICATIONS ARE THE PROPERTY OF DELTA ELECTRONICS MFG CORP. AND SHALL NOT BE REPRODUCED, OR COPIED OR USED AS THE BASIS FOR THE MANUFACTURE OR SALE OF APPARATUS OR DEVICES WITHOUT THEIR EXPRESS WRITTEN CONSENT.

CODE IDENT.-00795

1232-000-A00B