

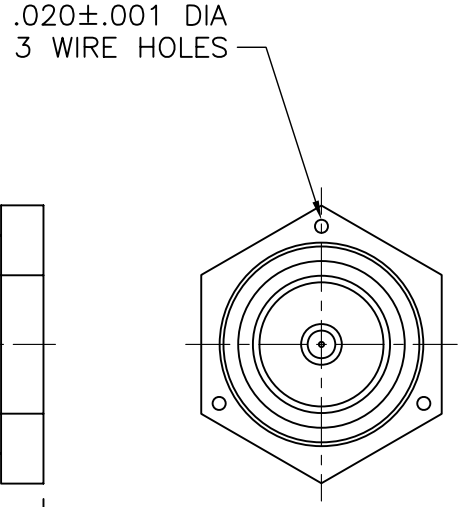

1303-037-K00E-2

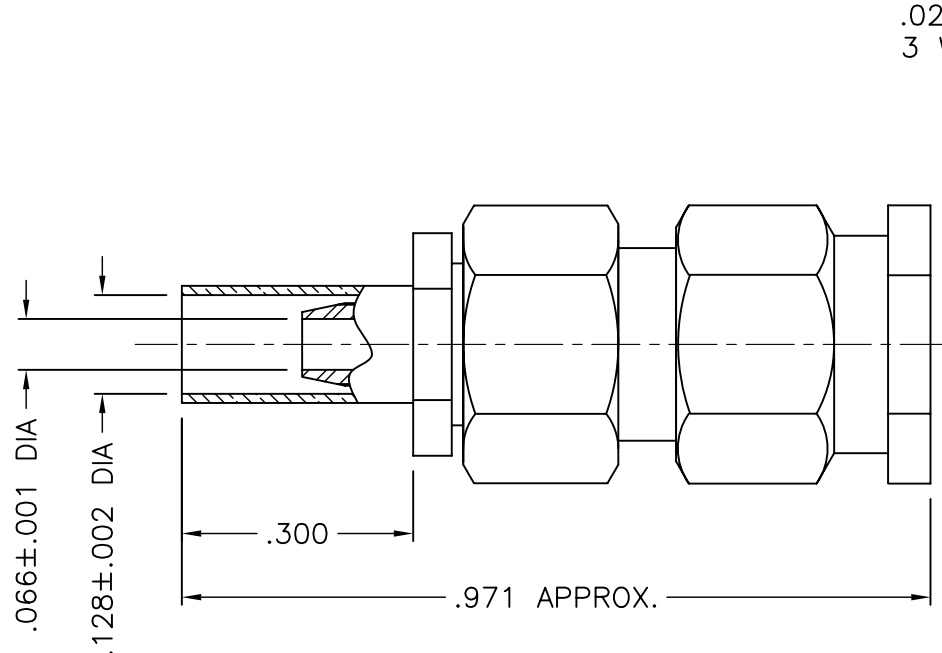
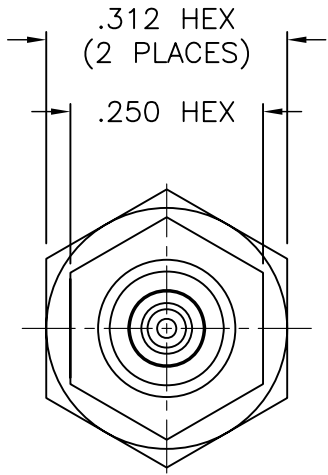

NOTES:

- ASSEMBLED CONNECTOR INTERFACE IS DESIGNED IN ACCORDANCE WITH MIL-STD-348.
- MATERIAL: CONTACT - BRASS PER ASTM B16
 INSULATOR - TEFLON PER ASTM D4894
 GASKET - SILICONE RUBBER PER A-A-59588
 CRIMP SLEEVE - D.H.P. COPPER CDA ALLOY 122
 ALL OTHER METAL PARTS - CORROSION RESISTANT STEEL PER ASTM A582
- FINISHES: CONTACT - GOLD PLATE PER ASTM B488
 CRIMP SLEEVE - SULFAMATE NICKEL PLATE PER MIL-P-27418
 ALL OTHER METAL PARTS - PASSIVATE PER QQ-P-35

M39012/55-3026

DELTA ELECTRONICS MFG. CORP. Beverly, MA 01915

TITLE: 'SMA' CRIMP PLUG FOR RG-174, 179B, 187A, 188A, 316/U CABLES - CAPTIVE CONTACT

UNLESS OTHERWISE SPECIFIED: TOLERANCES: 3 PLACES = ±.005, 2 PLACES = ±.02, ANGLES = ±1/2°, SURFACE FINISH = 63

-	OUTLINE	3/22/05
ALT.	REVISIONS	DATE

Drawn by BJM 3/22/05	Scale 4/1	Ckd. by MR	Engr Appd MR	FILE NAME: 1303037K00E-002T
----------------------------	--------------	---------------	-----------------	--------------------------------

THESE DRAWINGS AND SPECIFICATIONS ARE THE PROPERTY OF DELTA ELECTRONICS MFG CORP. AND SHALL NOT BE REPRODUCED, OR COPIED OR USED AS THE BASIS FOR THE MANUFACTURE OR SALE OF APPARATUS OR DEVICES WITHOUT THEIR EXPRESS WRITTEN CONSENT.

CODE IDENT.-00795

1303-037-K00E-2