



INSULATED WIRE
INCORPORATED



IW MICROWAVE PRODUCTS 2024

**Innovative specialists in
manufacture of microwave
cable & cable assemblies**

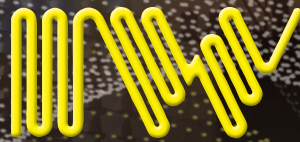

www.insulatedwire.com

CONTENTS

Company Profile	4	Re-Flex Introduction	58
Markets Served	6	Reflex Starter Kits	59
Cable Construction	8	RF 085 Series	60
Cable Construction Overview	10	RF 141 Series	64
Cable Capabilities	12	RF 250 Series	68
034 Series	14	Semi Rigid Series	72
047 Series	16	Connector Options	74
115 Series	18	Cable Assembly Part Number Builder	76
125 Series	20	Assembly Length Definition	78
140 Series	24	Coaxial Adapters	79
150 Series	28	Optional Protection	80
157 Series	32	Tuf-Flex™ Cable Performance	81
160 Series	34	Phase Match & Time Delay	82
180 Series	38	Phase Characteristics	83
230 Series	42	Engineering Design Data	84
280 Series	46	Cable Handling	85
480 Series	50		
750 Series	54		
75 Ω Products	56		

WELCOME

INSULATED WIRE TODAY

Founded in 1970, IW developed a unique PTFE lamination process and applied it to manufacturing wire and cable. This process allowed IW to manufacture products of unprecedented reliability along with smaller diameters. Combining the new lamination process along with a patented shield design allowed IW to become one of the leaders in low loss microwave transmission lines, utilizing both solid and expanded PTFE dielectrics. In 1988, IW expanded its operations and created a Microwave Products Division.

Today, IW Bayport designs and manufactures a wide range of cables to support demanding customer application specific requirements for high performance cable assemblies operating at frequencies up to 110GHz, across a range of diameters from 0.034" to 0.750" diameter. IW also offers a broad selection of connectors in order to provide our customers the proper cable assembly for specific applications.

IW operates in two facilities. Headquarters and cable manufacturing are located in Bayport, NY, with the cable assembly facility located close by in Ronkonkoma, NY. Both factories are AS9100 and ISO9001.

TECHNICAL SERVICES

All cable assemblies are built to customer specifications using the most advanced equipment and procedures including IPC-WHMA-A-620 trained technicians for soldering. All assemblies are tested for VSWR and insertion loss before leaving the factory. Phase matching, amplitude matching, and time delay measurements up to 67 GHz are available when required.

We can provide either in-house or an external laboratory for environmental testing such as humidity, salt spray, vibration, thermal shock, flex testing, as well as other unique requirements. Engineering support is also available for optimal cable/ connector configuration in rack systems, black boxes, and other packaging areas where transmission line performance is critical to the overall system performance.

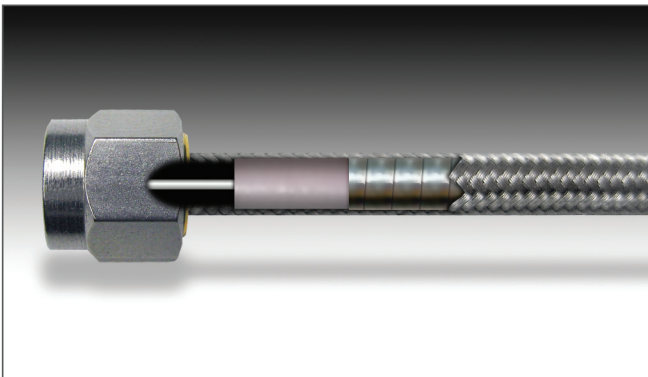

BULK CABLES

From basic hook up wire to composite multiconductor cables, Insulated Wire has been manufacturing high performance wire and cable products since 1970.

IW-Microwave Products Division's extremely Low Loss Cable Assemblies are optimized for operation in their respective frequency bands from low MHz to 67 GHz. Upon request we have the ability to accommodate custom assembly configurations, and can extrude a broad range of jacketing materials. Our jacketing capabilities allow us to produce assemblies that have extra flexibility, extended flex life, low and high temperature ranges, and resistance to oils and corrosive materials.

Our standard assemblies are extruded with FEP. Here is a list of other materials that are available but not limited to:

- FEP
- PFA
- Tefzel
- Silicone Rubber
- Low Smoke/Zero Halogen TPU



CABLE ASSEMBLIES

IW's extremely low loss cable assemblies are optimized for operation in their respective frequency bands from the low MHz to 110 GHz. Upon request we have the ability to accommodate custom assembly configurations, and can extrude a broad range of jacketing materials.

All of IW's coaxial cables are available as finished assemblies, including partially terminated cables, fully terminated, plus phase or time delay and offset matched sets.

With a wide range of interconnect products available, we're able to offer custom cable assembly lengths from a few inches to 100ft and above to suit your application. We offer a variety of connectors including SMA, TNCA, N-type, 3.5mm, 2.92mm, 1.85mm in straight, right angle, male and female, with bulkhead and four-hole flange mounting options available on some designs.

All connectors are designed to meet the requirements of MIL-PRF-39012 with interfaces compliant to MIL-STD-348. Our stainless steel designs ensure performance to 18 GHz for SMA, TNCA, and N-type, with right angle parts using swept center contacts to ensure optimum performance.

For high power applications, C, SC, 7/16, 1 5/8 and 3 1/8 EIA flanges are available for larger diameter cables (280, 480, 750 series), designed to ensure reliability in terms of power handling and heat transfer for continuous wave applications.

At millimeter wave, our smaller diameter cables (125, 115, 0471, 0341) have been developed to be compatible with industry standard connectors including most push-on interface styles, in addition to high frequency threaded types, with IW now offering cable assemblies that provide performance to 110 GHz.

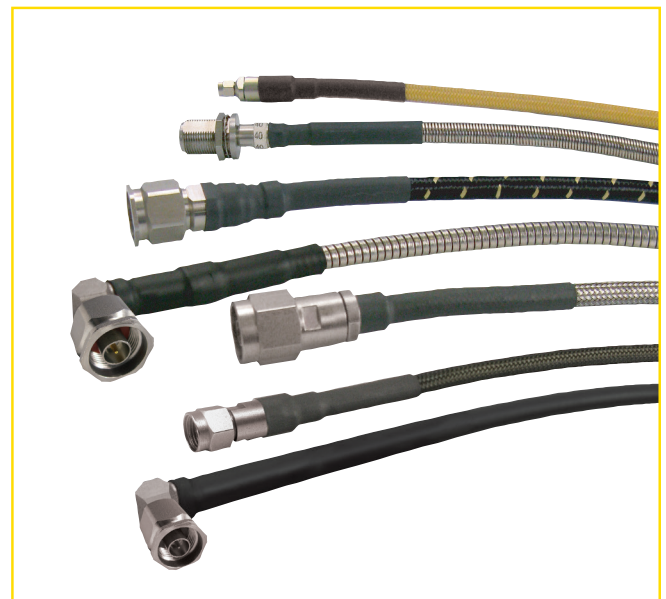

MARKETS SERVED

IW serves a broad range of both military and commercial markets. These include telecommunications, data links, satellite systems, airborne electronic warfare and counter measures, missile systems, UAV applications, avionics and instrumentation, fire control systems, medical electronics, and geophysical exploration.

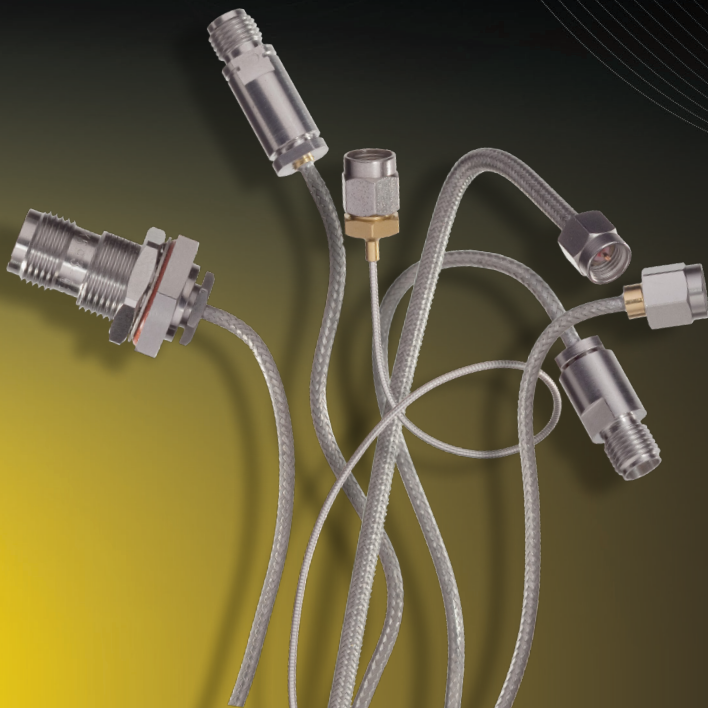

We're how the microwave industry gets connected!

- Aerospace
- Sub-Surface
- SatCom
- Missiles
- Ground Vehicles
- High End Audio
- Tactical Data Links
- IFF Systems
- CIWS
- UAVs
- Medical Electronics
- ECMs
- Geothermal Exploration
- Instrumentation
- High End Broadcast Telecommunications



CABLE CONSTRUCTION

TAILORED TO YOUR SPECIFICATIONS

IW is ready to work with you to provide the exact cable specifications you need for your extreme condition application. We start at square one, from initial specifications and requirements analysis; through the design phase using CAD, working with your systems and applications personnel; then through development, manufacturing and delivery; right up to hands on guidance for installation and maintenance.

The needs of each of our microwave customers are diverse and demanding and can change on a moment's notice. That's why we never rest on our laurels.

We are constantly working to develop the next new innovative machine, or to design the newest process for delivering state of the art microwave cables and assemblies.

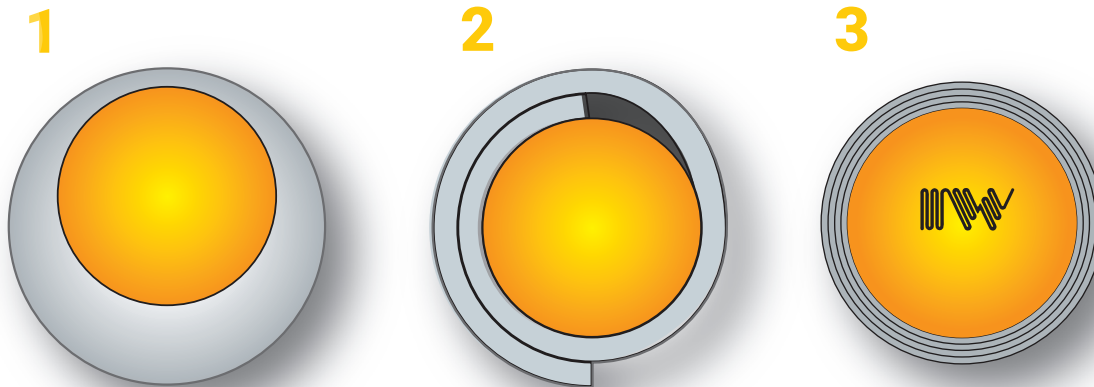

These scale drawings (approximately 50X actual size) illustrate IW's unique Multi-Ply Laminate insulation that eliminates the problems which occur with other forms of construction.

- 1 Extruded Insulation** requires a thicker insulating wall to compensate for the possibility of conductor eccentricity within the insulation.
- 2 Lap Wrap Tape Insulation** creates an irregular surface which precludes use with "O" ring seals at high pressures; contamination on the tape surface creates a low resistance path; and a corona site forms in the triangular voids created where the tape overlaps.
- 3 IW's Multi-Ply Laminate Insulation**, by contrast, delivers greater reliability with maximum space and weight savings.

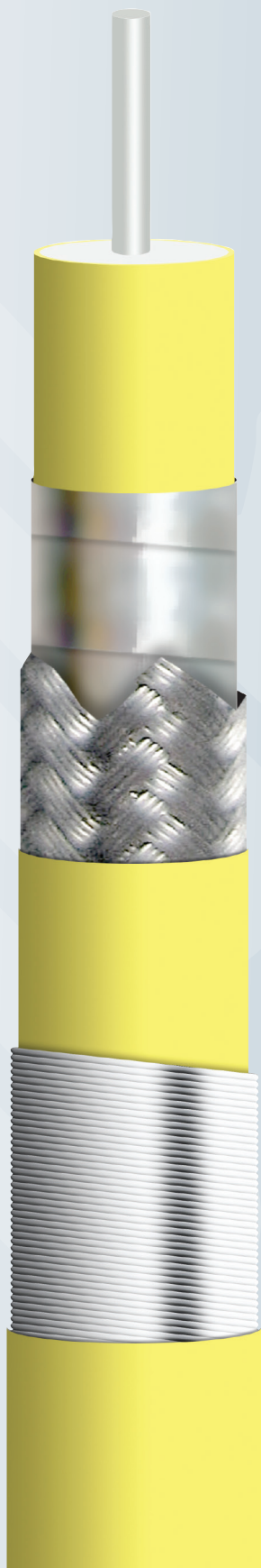

CENTER CONDUCTOR

Silver plated per ASTM B-298

DIELECTRIC

Multi-ply laminate
Per Mil-C-17
Expanded PTFE Type F-6
Solid PTFE Type F-2
All materials per ASTM D 4894

SHIELD

Helically wrapped silver or silver plated copper foil
ASTM-B-298

BRAID

Silver plated copper per ASTM B-298.
Braid coverage is greater than 98%
*Reflex per ASTM-B-33

JACKET

FEP per ASTM D-2116
FAA Flammability Test
UL94-VØ

SERVING**

Silver plated copper clad steel per ASTM B-501
**used on internally ruggedized cables

JACKET

FEP per ASTM D-2116

CABLE CONSTRUCTION - AN OVERVIEW

Upon request we have the ability to accommodate custom assembly configurations, and can extrude a broad range of jacketing materials.

Our jacketing capabilities allow us to produce assemblies that have extra flexibility, extended flex life, low and high temperature ranges, and resistance to oils and corrosive materials. Our standard assemblies are extruded with FEP.

Here is a list of other materials that are available:

- FEP
- PFA
- ETFE - Max temp range 200° C
- Low Smoke/Zero Halogen TPU
Max. Temp 90° C
- Santoprene - Max temp range 135° C

Below is an overview of our standard product selection, but as you peruse our catalog you can see we can offer you and your company a vast amount of options.

CABLE SPECIFICATIONS

P/N	Cable Diameter (Inches)	Static Bend Radius (Inches)	Dynamic Bend Radius (Inches)	Weight (lb/100 ft)	Capacitance (pF/ft)	Time Delay (nS/ft)	VP (%)	Cut Off Frequency (GHz)
0341	.057	.200	.375	.40	28.6	1.43	71	150
0471	.062	.200	.375	.47	28.6	1.43	71	110
1151	.104	.250	.625	1.20	26.8	1.34	76	61
1251	.099	.250	.625	1.20	26.8	1.34	76	70
1401	.130	.500	1.000	1.90	24.5	1.27	80	50
1403	.186	.750	1.375	5.10	24.5	1.27	80	50
1406	.130	.500	1.00	1.80	25.4	1.27	80	50
1501	.144	.500	1.250	2.20	25.4	1.27	80	43
1503	.201	.75	1.75	4.70	25.4	1.27	80	43
1506	.144	.500	1.250	2.20	25.4	1.27	80	42
1571	.155	.500	1.250	2.60	24.5	1.27	80	41.5
1573	.213	.750	1.500	6.00	24.5	1.27	80	41.5
1601	.160	.375	1.000	3.10	28.6	1.43	71	34
1603	.218	.675	1.500	6.50	28.6	1.43	71	34
1801	.188	.750	1.250	3.70	24.5	1.22	83	32
1803	.255	.875	1.750	8.70	24.5	1.22	83	32
1806	.185	.625	1.250	3.50	24.5	1.22	83	32
1808	.252	.875	1.750	8.40	24.5	1.22	83	26.5
2301	.223	.750	1.375	4.80	24.5	1.22	83	26.5
2303	.292	1.000	2.000	10.60	24.5	1.22	83 2	6.5
2306	.215	.625	1.250	4.60	24.5	1.22	83	26.5
2308	.284	.875	1.750	9.90	24.5	1.22	83	26.5

CABLE CONSTRUCTION - AN OVERVIEW (continued)

CABLE SPECIFICATIONS

P/N	Cable Diameter (Inches)	Static Bend Radius (Inches)	Dynamic Bend Radius (Inches)	Weight (lb/100 ft)	Capacitance (pF/ft)	Time Delay (nS/ft)	VP (%)	Cut Off Frequency (GHz)
2801	.303	1.000	1.750	8.30	24.5	1.22	83	18.5
2803	.374	1.375	2.500	15.70	24.5	1.22	83	18.5
2806	.296	1.000	2.000	7.90	24.5	1.22	83	18.5
2808	.365	1.375	2.500	15.40	24.5	1.22	83	18.5
4806	.475	3.000	5.000	18.30	24.5	1.22	83	11.3
7506	.765	5.000	8.000	36.00	24.5	1.22	83	06.5
1151-75	.106	0.250	0.625	1.30	19.1	1.43	71	65.0
1601-75	.161	0.250	1.000	2.90	19.1	1.43	71	35.0
1801-75	.193	0.625	1.125	3.40	16.3	1.22	83	34.0
2801-75	.307	1.000	1.750	7.10	16.3	1.22	83	19.5
RF085	.085	0.250	0.375	1.20	29.0	1.45	70	61.0
RF141	.142	0.375	0.750	2.60	29.0	1.45	70	34.0
RF250	.230	0.375	1.000	6.25	29.0	1.45	70	18.0
RF325	.325	0.625	2.250	7.70	29.0	1.45	70	10.0
50S047	.047	0.062	-	0.38	29.0	1.45	70	110.0
50S080	.088	0.125	-	1.64	28.6	1.43	71	62.0
50S141	.141	0.250	-	3.25	8.6	.43	71	35.0
50S250	.250	0.375	-	11.00	28.6	1.43	71	18.0

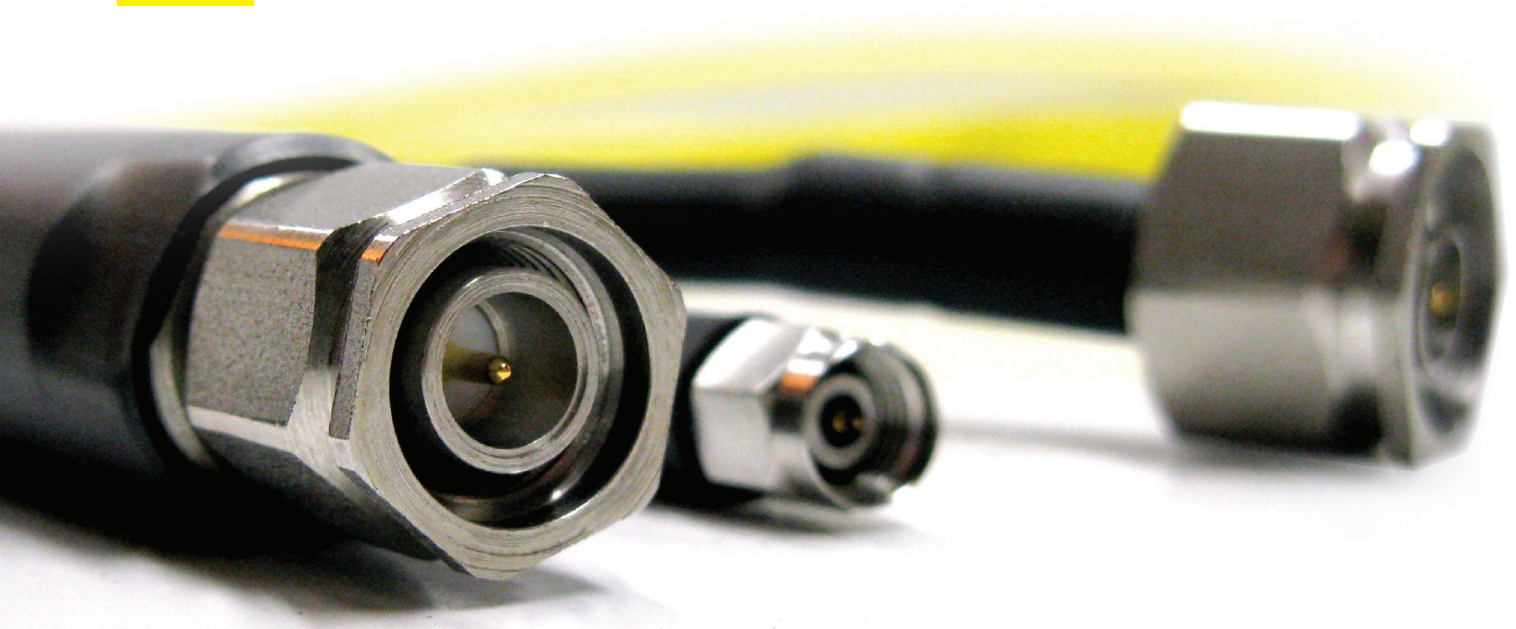

CABLE CAPABILITIES - OVERVIEW

IW Microwave Products has the capability to supply composite RF & microwave assemblies for various applications including marine platforms such as submarines. One example is a multicable type assembly which includes twisted pair, twisted triple, 16AWG and custom coaxial cable.

All cable products are designed and manufactured at the Insulated Wire Headquarters facility at Bayport, NY, with the coaxial connectors and cable assemblies prepared at the Microwave Products location, located close by at Ronkonkoma, NY.

MECHANICAL CONSTRUCTION

IW's composite cables provide a myriad of options. Components can include individually shielded and jacketed signal transmission cables, power cables, microwave cables and fiber optic. Depending on the application, cables can be optimized to address issues such as hydrostatic pressure, tensile loads, concentrated compression points, etc. Overall shielding can be provided with ferrous or nonferrous materials. High performance, non-metallic braids and strength members, such as Kevlar™ are also available.

The cable shown here was produced for a submarine application and contains multiple, individual signal cables and IW's Tuf-Flex™ microwave cables for use at frequencies up to 18 GHz. Water block fillers and binders are incorporated under a double braided Sn/Cu braid and polyurethane jacket. Cable withstands the anticipated environmental extremes in accordance with the method requirements of MIL-DTL-24643B par 4.8.8 and can withstand hydrostatic pressure up to 1050 psi.

IW provides hands on service to install and troubleshoot cabling, like this complex wire created for the US Navy.

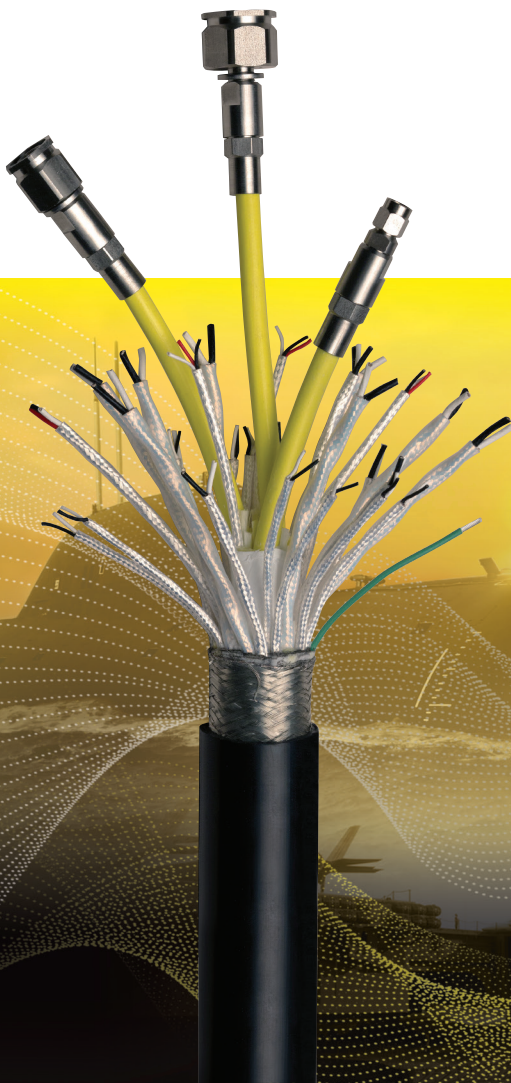

PRODUCT RANGE - OVERVIEW

Our product range of coaxial cables are designed to meet IW specifications for high performance across the electromagnetic spectrum to 150 GHz.

All of IW's coaxial cables are available as finished assemblies, including partially terminated cables, fully terminated, plus phase or time delay and offset matched sets.

Offering optional Protection Microwave transmission lines are quite often exposed to a wide range of hostile environments. These may include extreme temperature, abrasion, comprehensive forces, high pressure fluids, solvents, chemicals, salt water, UV, vibration, and mechanical stress, just to name a few.

Insulated Wire has the capability to supply composite RF & microwave assemblies for various applications. With complete control of the manufacturing process, IW is able to offer custom solutions based on standard process and product for many types of applications.

To provide improved electrical and mechanical performance over traditional hand-formable designs, Insulated Wire presents Re-Flex™.

Insulated Wire now offers four line sizes of 75Ω cables utilizing the same technology and materials that give our 50Ω products industry leading attenuation performance.

0.034-0.750" LOW LOSS/PHASE STABLE COAX

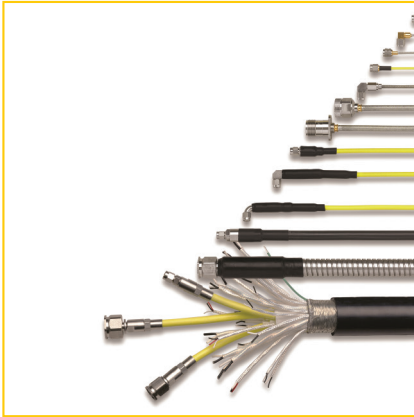

CABLE ASSEMBLIES



CUSTOM DESIGN

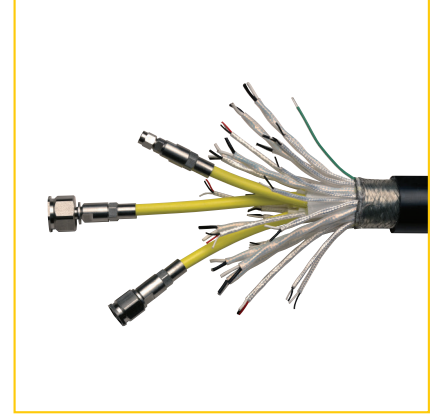

RE-FLEX™ HAND-FORMABLE COAX



HIGH PERFORMANCE 75Ω



SEMI RIGID

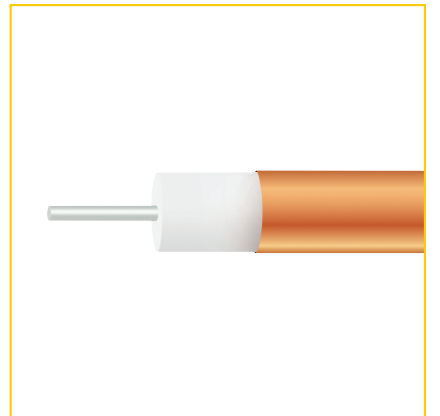



034 SERIES

OPERATING UP TO 150 GHz

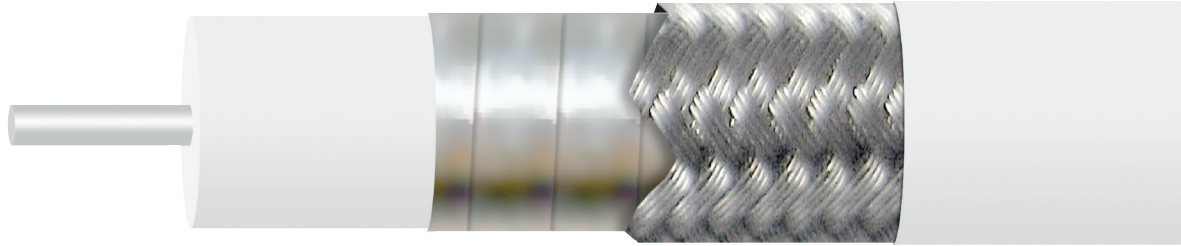

Center Conductor
Silver Plated Copper

Dielectric
Laminated
PTFE

Foil
Silver Plated
Copper

Braid
Silver Plated
Copper

Outer Jacket
FEP
(0.057", 1.45 mm)

CABLE SPECIFICATIONS

	0341
ELECTRICAL CHARACTERISTICS	
Impedance	50 +/- 2Ω
Cut Off Frequency (cable only, max)	150 GHz
Capacitance	28.6 pF/ft.
Velocity of Propagation	71%
Time Delay	1.43 ns/ft.
Shielding Effectiveness up to 18GHz	>90 dB
Cable Attenuation Factors *	K1 = 53, K2 = 0.90
Power Handling	See Chart
MECHANICAL CHARACTERISTICS	
Weight	0.064oz/ft (5.95g/m)
Static Bend Radius	0.2" (5.1mm)
Dynamic Bend Radius	0.375" (9.5mm)
ENVIRONMENTAL CHARACTERISTICS	
Operating Temperature Range	-65°C to +150°C
RoHS 3 (EU 2015/863)	Yes

*Standard cable assembly temperature range is -55°C to +135°C, -65°C to +150°C available for select configurations

*Attenuation = $K1\sqrt{f} + K2f$ (cable only)



034 SERIES

OPERATING UP TO 150 GHz

CABLE ATTENUATION

ATTENUATION (MAX)

0341

GHz	dB/ft.	dB/m	Power(W) @ 20°C @ Sea Level
0.5	0.38	1.24	20.0
1	0.54	1.77	10.2
2	0.77	2.52	8.0
4	1.10	3.59	4.8
8	1.57	5.15	3.2
12	1.94	6.38	2.6
18	2.41	7.91	6.5
20	2.55	8.36	2.1
24	2.81	9.22	1.7
30	3.17	10.41	1.5
40	3.71	12.18	1.1
50	4.20	13.77	1.0
60	4.65	15.24	1.0
70	5.06	16.61	0.9
80	5.46	17.91	0.8
90	5.84	19.15	0.7
100	6.20	20.34	0.7
110	6.55	21.48	0.6
120	6.89	22.59	0.5
130	7.21	23.66	0.5
140	7.53	24.70	0.4
150	7.84	25.72	0.3

dB/ft
10.00

ATTENUATION

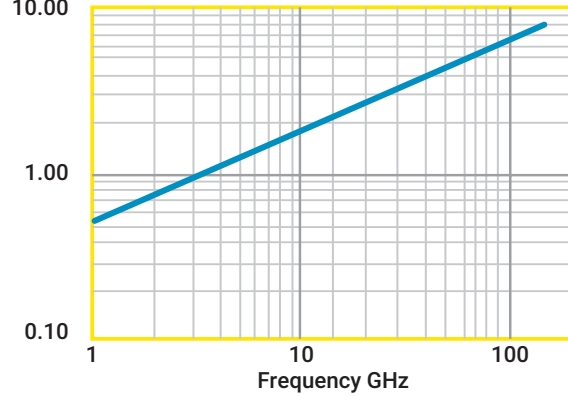

dB/m
10.00

ATTENUATION

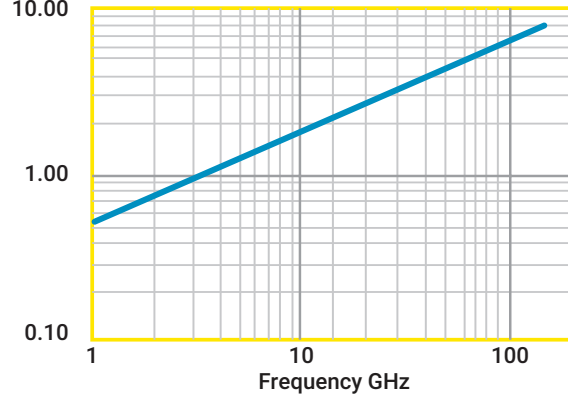

Watts
100

MAX RF POWER AT 20°C AT SEA LEVEL

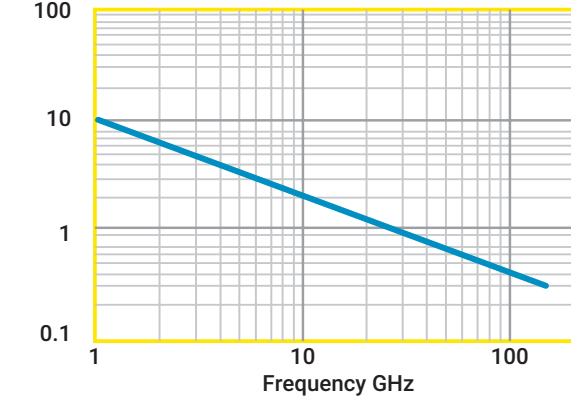



047 SERIES
OPERATING UP TO 110 GHz



Center Conductor
Silver Plated Copper

Dielectric
PTFE

Foil
Silver Plated
Copper

Braid
Silver Plated
Copper

Outer Jacket
FEP
(0.062", 1.63mm)

CABLE SPECIFICATIONS

	0471
ELECTRICAL CHARACTERISTICS	
Impedance	50 +/- 2Ω
Cut Off Frequency (cable only, max)	110 GHz
Capacitance	28.6 pF/ft
Velocity of Propagation	71%
Time Delay	1.43 ns/ft.
Shielding Effectiveness up to 18GHz	>90 dB
Cable Attenuation Factors *	K1 = 37.5, K2 = 0.935
Power Handling	See Chart
MECHANICAL CHARACTERISTICS	
Weight	0.08 oz/ft (7.4 g/m)
Static Bend Radius	0.2" (5.1mm)
Dynamic Bend Radius	0.375" (9.5mm)
ENVIRONMENTAL CHARACTERISTICS	
Operating Temperature Range	-65°C to +150°C
RoHS 3 (EU 2015/863)	Yes

*Standard cable assembly temperature range is -55°C to +135°C, -65°C to +150°C available for select configurations

*Attenuation = $K1\sqrt{f} + K2f$ (cable only)



047 SERIES

OPERATING UP TO 110 GHz

CABLE ATTENUATION

ATTENUATION (MAX)			
0471			
GHz	dB/ft.	dB/m	Power(W) @ 20°C @ Sea Level
0.5	0.27	0.89	55.8
1	0.38	1.26	32.0
2	0.55	1.80	25.0
4	0.79	2.58	15.0
6	0.97	3.20	12.0
8	1.14	3.73	10.0
10	1.28	4.20	9.0
12	1.41	4.63	8.0
14	1.53	5.03	7.5
16	1.65	5.41	7.0
18	1.76	5.77	6.5
20	1.86	6.12	6.0
22	1.96	6.45	5.6
24	2.06	6.76	5.3
26	2.16	7.07	5.0
28	2.25	7.37	4.8
30	2.33	7.66	4.6
40	2.75	9.01	3.4
50	3.12	10.23	3.2
60	3.47	11.37	3.0
70	3.79	12.44	2.2
80	4.10	13.46	2.4
90	4.40	14.43	2.3
100	4.69	15.37	2.01
110	4.96	16.28	2.0
90	4.35	14.27	2.3
100	4.65	15.27	2.1
110	4.96	16.28	2.0

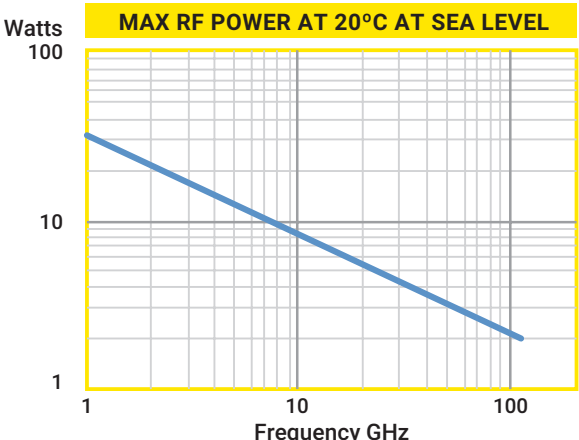
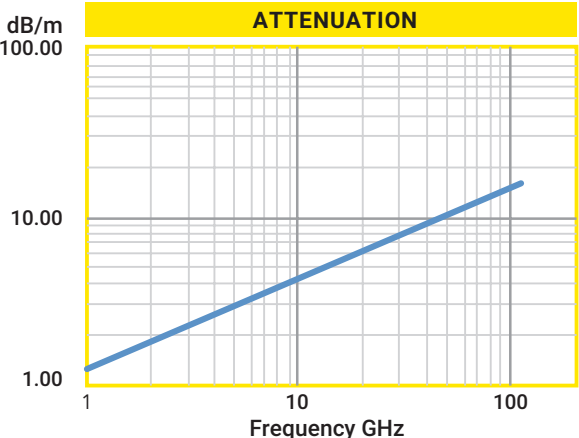
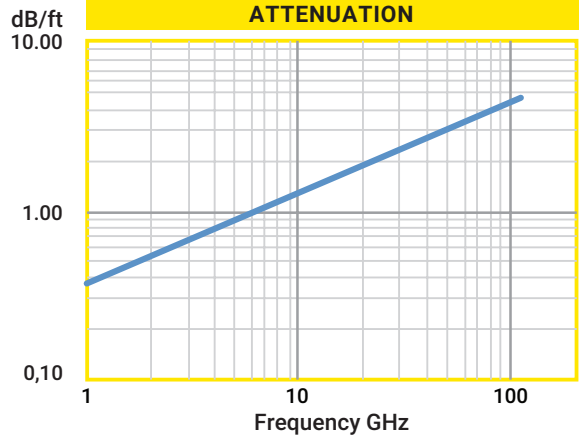



115 SERIES

OPERATING UP TO 62 GHz



Center Conductor
Silver Plated Copper
1151 Solid
1156 Stranded

Dielectric
PTFE

Foil
Silver Plated
Copper

Braid
Silver Plated
Copper

Outer Jacket
FEP
(0.104", 2.64mm)

CABLE SPECIFICATIONS

	1151	1156
ELECTRICAL CHARACTERISTICS		
Impedance	50 +/- 2Ω	50 +/- 2Ω
Cut Off Frequency (cable only, max)	61 GHz	65 GHz
Capacitance	29 pF/ft.	29 pF/ft.
Velocity of Propagation	71%	71%
Time Delay	1.43 ns/ft.	1.43 ns/ft.
Shielding Effectiveness up to 18GHz	>90 dB	>90 dB
Cable Attenuation Factors (K1, K2) *	19.4, 0.89	23, 0.87
Power Handling	See Chart	See Chart
MECHANICAL CHARACTERISTICS		
Weight	.22 oz/ft (20.8 g/m)	.21 oz/ft (19.3 g/m)
Static Bend Radius	0.25" (6.35mm)	0.25" (3.17mm)
Dynamic Bend Radius	0.625" (15.9mm)	0.5" (12.7mm)
ENVIRONMENTAL CHARACTERISTICS		
Operating Temperature Range ¹	-65°C to +200°C	-65°C to +200°C
RoHS 3 (EU 2015/863)	Yes	Yes

¹ Standard cable assembly temperature range is -55°C to +165°C, -65°C to +200°C available for select configurations

VSWR for assemblies with two straight connectors 1.35:1 to 18 GHz 1.35:1 to 18 GHz

VSWR for assemblies with one straight and one right angle connector 1.40:1 to 18 GHz 1.40:1 to 18 GHz

VSWR for assemblies with two right angle connectors 1.45:1 to 18 GHz 1.45:1 to 18 GHz

*Attenuation = $K1\sqrt{f} + K2f$ (cable only)

1151 is a flexible replacement for RG405 cable



115 SERIES

OPERATING UP TO 62 GHz

CABLE ATTENUATION

ATTENUATION (MAX)						
1151			1156			
GHz	dB/ft.	dB/m	Power(W) @ 20°C @ Sea Level	dB/ft.	dB/m	Power(W) @ 20°C @ Sea Level
0.5	0.14	0.46	357	0.17	0.55	310
1	0.20	0.67	220	0.24	0.78	196
2	0.29	0.96	200	0.34	1.12	170
4	0.42	1.39	120	0.49	1.62	107
A	0.53	1.73	85	0.62	2.02	76
8	0.62	2.03	75	0.72	2.36	67
10	0.70	2.30	70	0.81	2.67	63
12	0.78	2.56	65	0.90	2.96	58
14	0.85	2.79	60	0.98	3.22	54
16	0.92	3.01	55	1.06	3.48	49
18	0.98	3.23	50	1.13	3.72	45
20	1.04	3.42	45	1.19	3.89	40
22	1.10	3.62	43	1.26	4.13	38
24	1.17	3.82	42	1.33	4.36	38
26	1.23	4.02	40	1.40	4.58	36
28	1.28	4.21	39	1.46	4.80	35
30	1.34	4.40	38	1.53	5.01	34
32	1.40	4.58	37	1.59	5.22	33
34	1.45	4.76	36	1.65	5.43	32
36	1.51	4.94	35	1.72	5.63	31
38	1.56	5.11	32	1.78	5.83	29
40	1.61	5.28	30	1.84	6.02	27
42	1.66	5.45	29	1.90	6.22	26
44	1.71	5.62	28	1.95	6.41	25
46	1.76	5.79	27	2.01	6.60	24
48	1.81	5.95	26	2.07	6.78	23
50	1.86	6.11	25	2.12	6.97	22
52	1.91	6.27	25	2.18	7.15	22
54	1.96	6.43	25	2.24	7.33	22
56	2.01	6.59	23	2.29	7.51	21
58	2.06	6.74	23	2.34	7.69	21
60	2.10	6.90	22	2.40	7.86	20
62	2.15	7.05	22	2.45	8.04	20

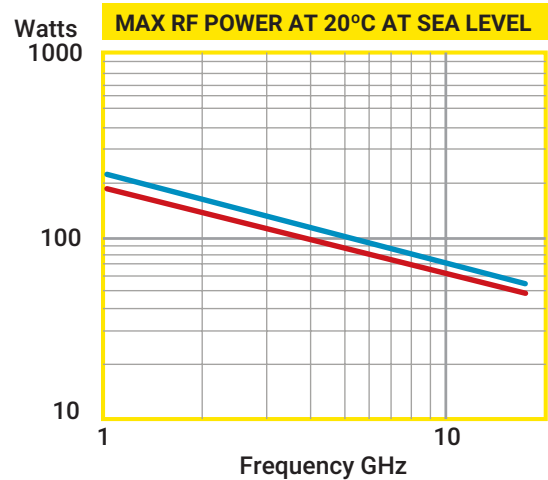
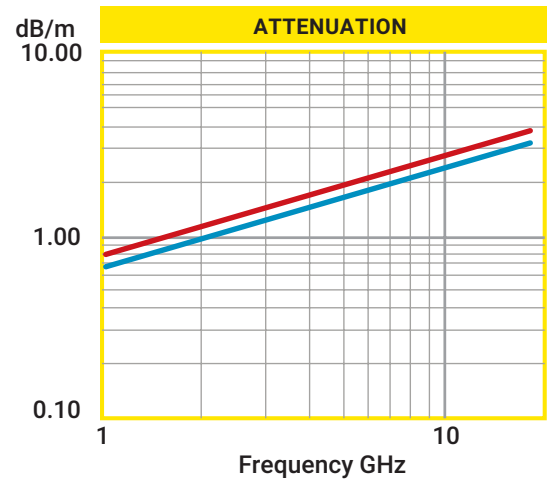
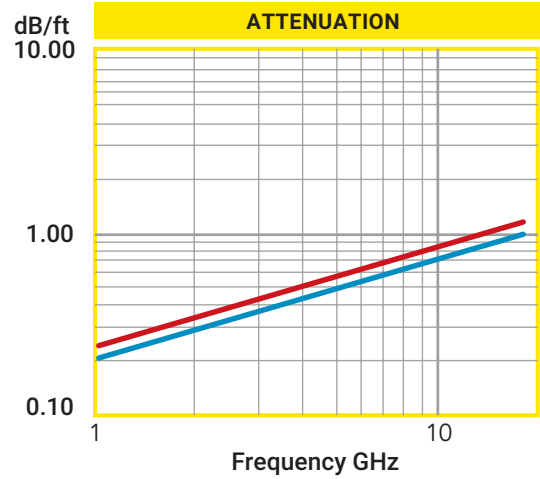



125 SERIES

OPERATING UP TO 70 GHz



Center Conductor
Silver Plated Copper

Dielectric
EPTFE

Foil
Silver Plated
Copper

Braid
Silver Plated
Copper

Outer Jacket
FEP
(0.099", 2.51mm)

CABLE SPECIFICATIONS

	1251
ELECTRICAL CHARACTERISTICS	
Impedance	50 +/- 2Ω
Cut Off Frequency (cable only, max)	70 GHz
Capacitance	26.8 pF/ft.
Velocity of Propagation	76%
Time Delay	1.34 ns/ft.
Shielding Effectiveness up to 18GHz	>100 dB
Cable Attenuation Factors *	K1 = 19.4, K2 = 0.58
Power Handling	See Chart
MECHANICAL CHARACTERISTICS	
Weight	.19 oz/ft (17.9 g/m)
Static Bend Radius	0.25" (6.35mm)
Dynamic Bend Radius	0.625" (15.87mm)
ENVIRONMENTAL CHARACTERISTICS	
Operating Temperature Range	-65°C to +200°C
RoHS 3 (EU 2015/863)	Yes

¹ Standard cable assembly temperature range is -55°C to +165°C, -65°C to +200°C available for select configurations

VSWR for assemblies with two straight connectors

1.35 : 1 to 40 GHz

*Attenuation = $K1\sqrt{f} + K2f$ (cable only)



125 SERIES

OPERATING UP TO 70 GHz

CABLE ATTENUATION

ATTENUATION (MAX)

1251

GHz	dB/ft.	dB/m	Power(W) @ 20°C @ Sea Level
0.5	0.14	0.46	410
1	0.20	0.66	220
2	0.29	0.94	200
4	0.41	1.35	120
6	0.51	1.67	85
8	0.60	1.95	75
10	0.67	2.20	70
12	0.74	2.43	65
14	0.81	2.65	60
16	0.87	2.85	55
18	0.93	3.04	50
20	0.98	3.23	45
22	1.04	3.40	43
24	1.09	3.57	42
26	1.14	3.74	40
28	1.19	3.90	39
30	1.24	4.06	38
32	1.28	4.21	37
34	1.33	4.36	36
36	1.37	4.50	35
38	1.42	4.65	32
40	1.46	4.79	30
42	1.50	4.92	29
44	1.54	5.06	28
46	1.58	5.19	27
48	1.62	5.32	26
50	1.66	5.45	25
52	1.70	5.58	25
54	1.74	5.71	25
56	1.78	5.83	23
58	1.81	5.95	23
60	1.85	6.07	22
62	1.89	6.19	22
64	1.92	6.31	22
65	1.96	6.43	21
68	1.99	6.54	20
70	2.03	6.66	19

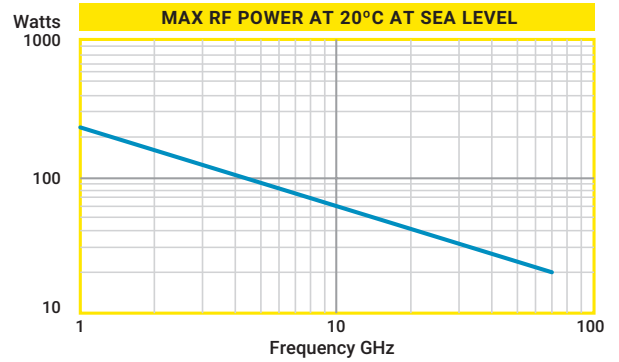
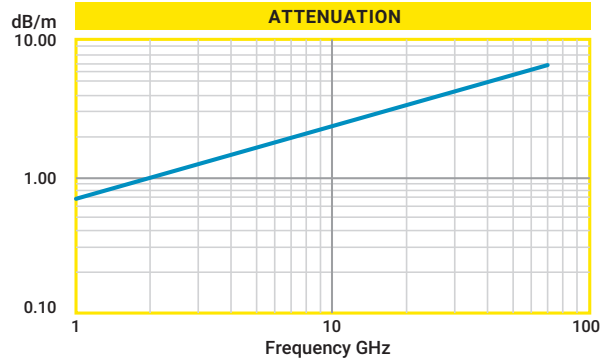
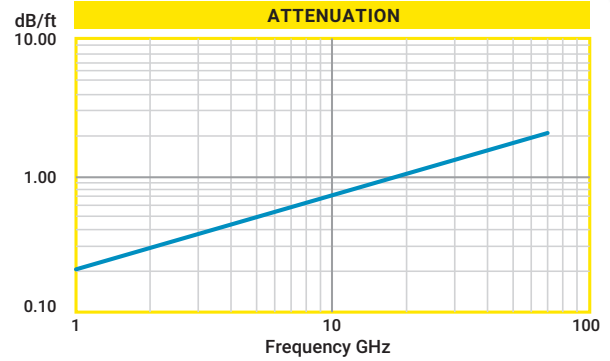



CONNECTORS FOR 125 SERIES

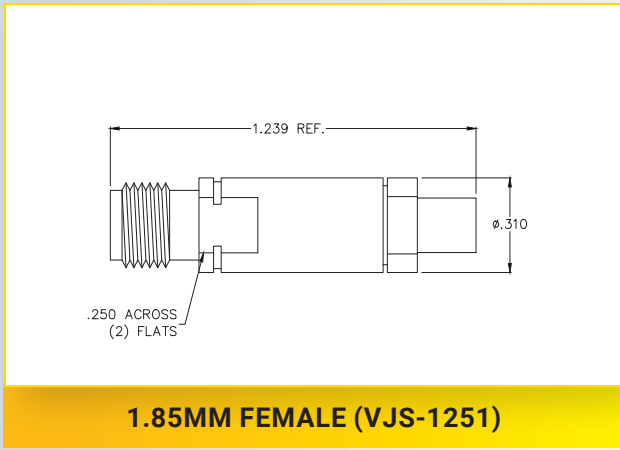
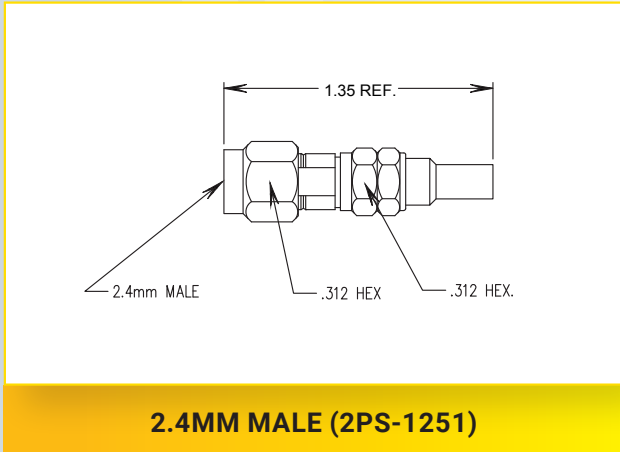
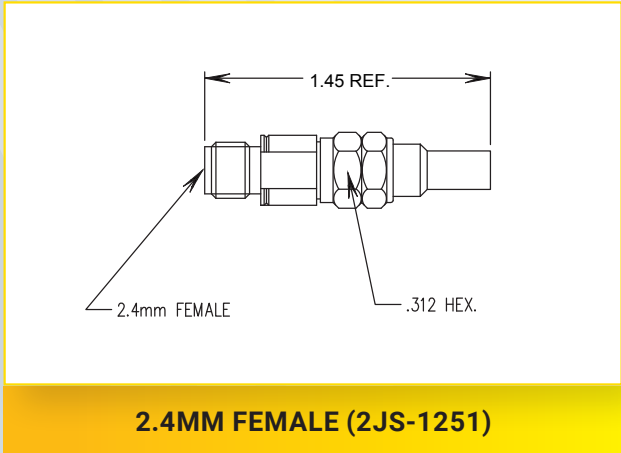

Other connector types and styles are available, please contact the factory



CONNECTORS FOR 125 SERIES

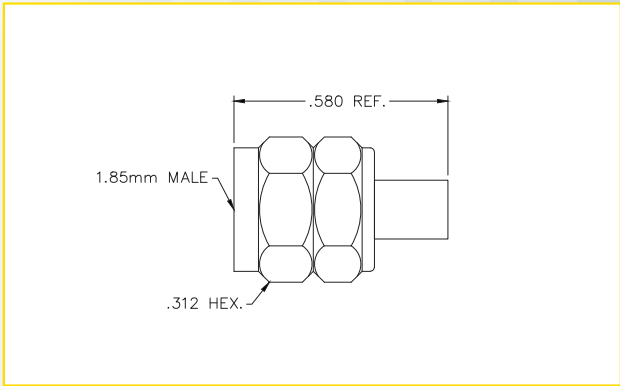

1.85MM MALE SHELL STYLE (VPSH-1251)

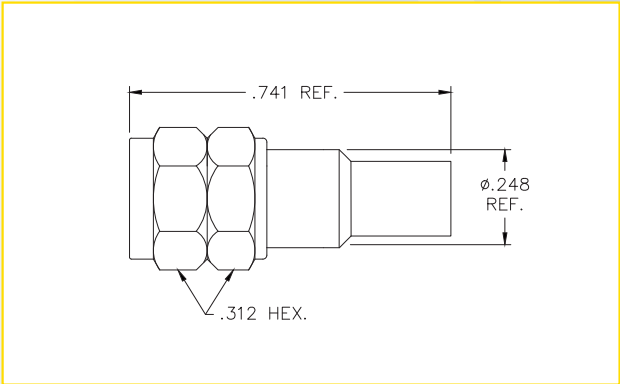

1.85MM MALE SHELL STYLE FOR EXTERNAL ARMOR (VJS-1251A)

Other connector types and styles are available, please contact the factory



140 SERIES

OPERATING UP TO 50 GHz

140 SERIES

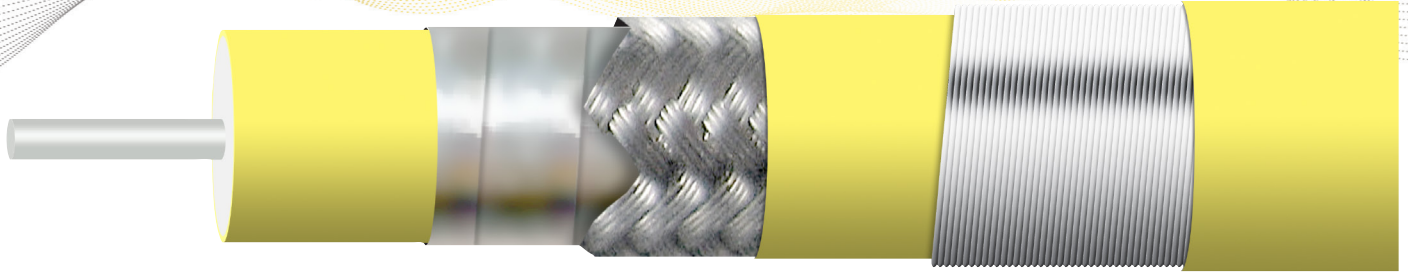

Center Conductor
Silver Plated Copper
1401/1403 Solid
1406/1408 Stranded

Dielectric
EPTFE

Foil
Silver Plated
Copper

Braid
Silver Plated
Copper

Inner Jacket
FEP
(0.130", 3.30mm)

Serving
SCCS Armor

Outer Jacket
FEP
(0.186", 4.72mm)

CABLE SPECIFICATIONS

	1401	1406	1403	1408
ELECTRICAL CHARACTERISTICS				
Impedance	50 +/- 2Ω	50 +/- 2Ω	50 +/- 2Ω	50 +/- 2Ω
Cut Off Frequency (cable only, max)	50 GHz	50 GHz	50 GHz	50 GHz
Capacitance	24.5 pF/ft.	25.4 pF/ft.	24.5 pF/ft.	25.4 pF/ft.
Velocity of Propagation	80%	80%	80%	80%
Time Delay	1.27 ns/ft.	1.27 ns/ft.	1.27 ns/ft.	1.27 ns/ft.
Shielding Effectiveness up to 18GHz	>100 dB	>100 dB	>100 dB	>100 dB
Cable Attenuation Factors (K1, K2) *	12.9, 0.195	14.5, 0.190	12.9, 0.195	14.5, 0.190
Power Handling	See Chart	See Chart	See Chart	See Chart
MECHANICAL CHARACTERISTICS				
Weight	.30 oz/ft (28g/m)	.29 oz/ft (27 g/m)	.83 oz/ft (77 g/m)	.82 oz/ft (76 g/m)
Static Bend Radius	0.5" (12.7mm)	0.5" (12.7mm)	0.75" (19.1mm)	0.75" (19.1mm)
Dynamic Bend Radius	1.0" (25.4mm)	1.0" (25.4mm)	1.375" (34.9mm)	1.375" (34.9mm)
ENVIRONMENTAL CHARACTERISTICS				
Operating Temperature Range ¹	-65°C to +200°C	-65°C to +200°C	-65°C to +200°C	-65°C to +200°C
RoHS 3 (EU 2015/863)	Yes	Yes	Yes	Yes

¹ Standard cable assembly temperature range is -55°C to +165°C, -65°C to +200°C available for select configurations

VSWR for assemblies with two
straight 2.4 mm connectors

1.40 : 1 to 50 GHz

1.40 : 1 to 50 GHz

1.40 : 1 to 50 GHz

1.40 : 1 to 50 GHz

*Attenuation = $K1\sqrt{f} + K2f$ (cable only)



140 SERIES

OPERATING UP TO 50 GHz

CABLE ATTENUATION

ATTENUATION (MAX)

1401/1403

1406/1408

GHz	dB/ft.	dB/m	Power(W) @ 20°C @ Sea Level	dB/ft.	dB/m	Power(W) @ 20°C @ Sea Level
0.5	0.09	0.30	688	0.10	0.34	608
1	0.13	0.43	450	0.15	0.48	402
2	0.19	0.61	300	0.21	0.69	268
4	0.27	0.87	225	0.30	0.98	201
6	0.33	1.08	185	0.37	1.20	156
8	0.38	1.25	150	0.43	1.40	134
10	0.43	1.40	140	0.48	1.57	125
12	0.47	1.54	120	0.53	1.72	107
14	0.51	1.67	110	0.57	1.87	98
16	0.55	1.80	105	0.61	2.00	94
18	0.58	1.91	100	0.65	2.13	89
20	0.62	2.02	95	0.69	2.25	85
22	0.65	2.13	90	0.72	2.37	80
24	0.68	2.23	85	0.76	2.48	76
26	0.69	2.28	80	0.77	2.53	71
28	0.71	2.32	75	0.79	2.59	67
30	0.77	2.51	73	0.85	2.79	65
32	0.79	2.60	71	0.88	2.89	63
34	0.82	2.69	70	0.91	2.99	63
36	0.84	2.77	68	0.94	3.08	61
38	0.87	2.85	65	0.97	3.17	58
40	0.89	2.93	60	0.99	3.26	54
42	0.92	3.01	58	1.02	3.35	52
44	0.94	3.09	56	1.05	3.43	50
46	0.96	3.16	54	1.07	3.51	48
48	0.99	3.24	52	1.10	3.60	46
50	1.01	3.31	50	1.12	3.68	44

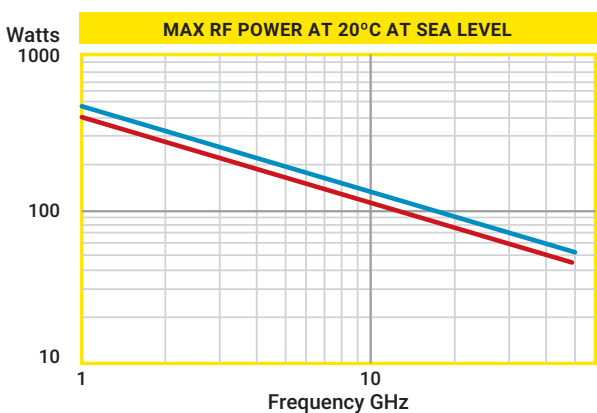
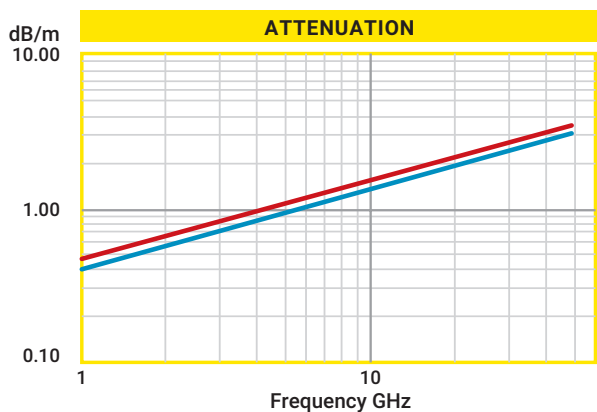
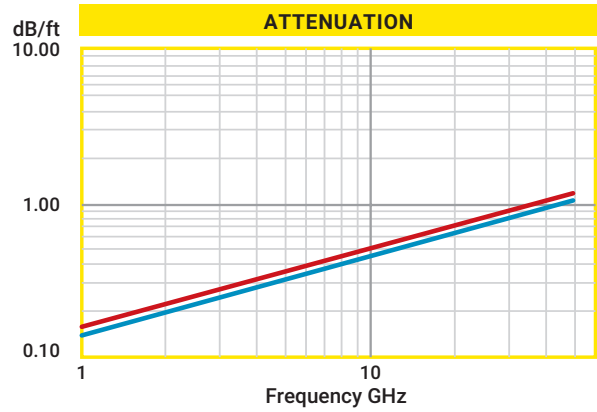



CONNECTORS FOR 140 SERIES

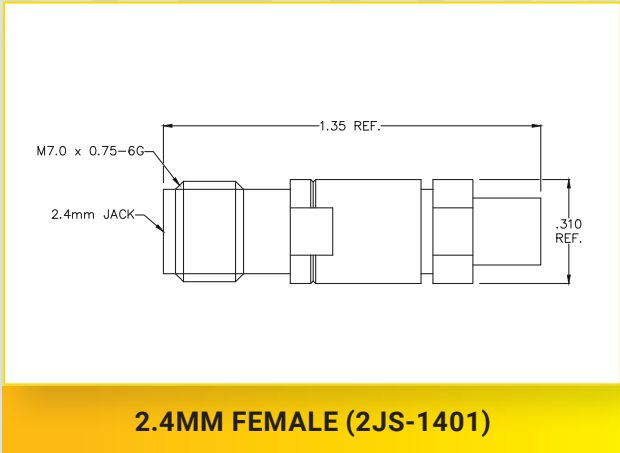

2.4MM FEMALE (2JS-1401)

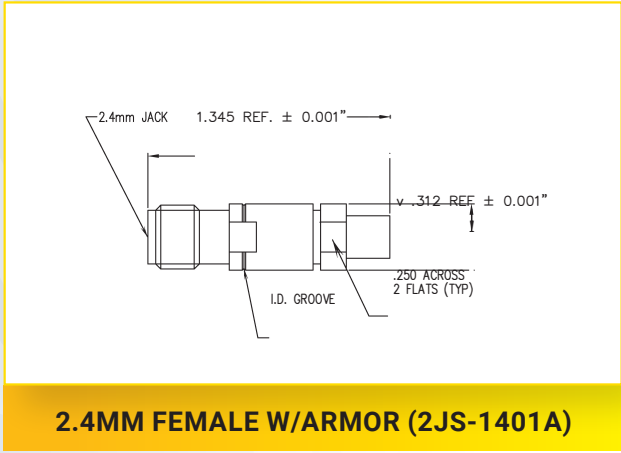

2.4MM FEMALE W/ARMOR (2JS-1401A)

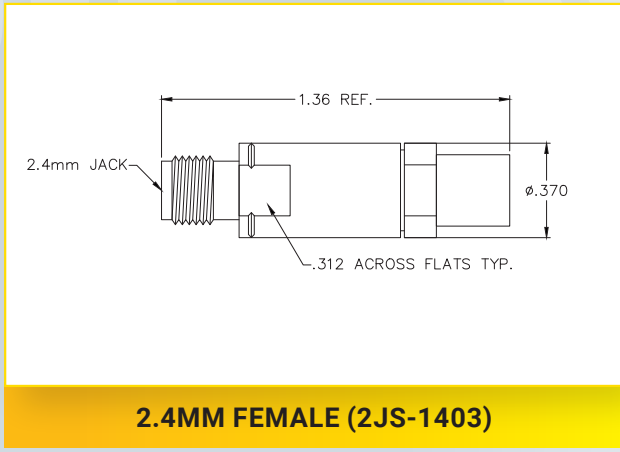

2.4MM FEMALE (2JS-1403)

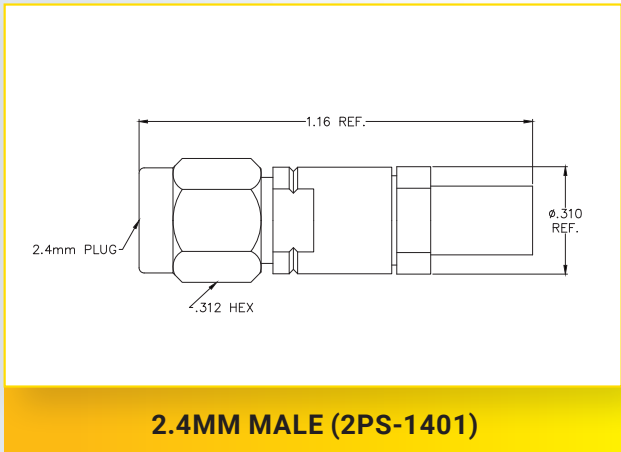

2.4MM MALE (2PS-1401)

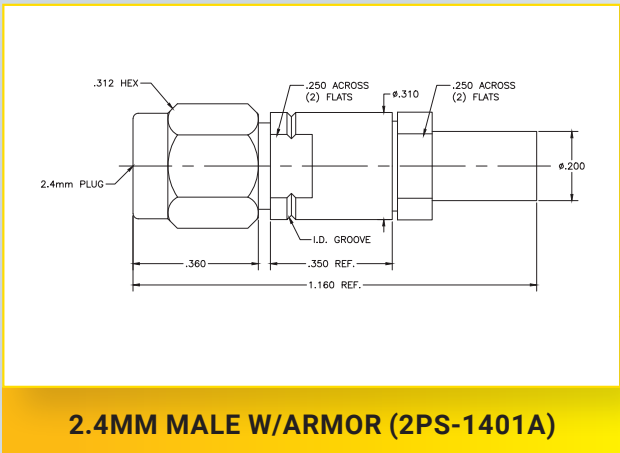

2.4MM MALE W/ARMOR (2PS-1401A)



CONNECTORS FOR 140 SERIES

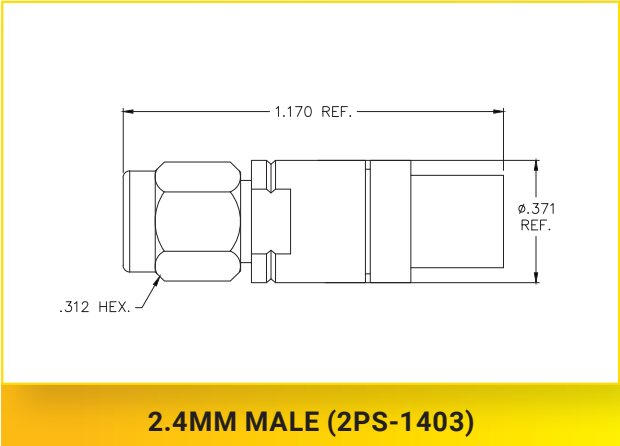

2.4MM MALE (2PS-1403)

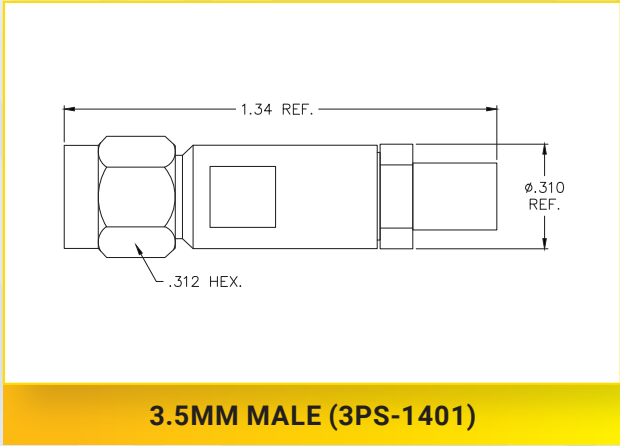

3.5MM MALE (3PS-1401)

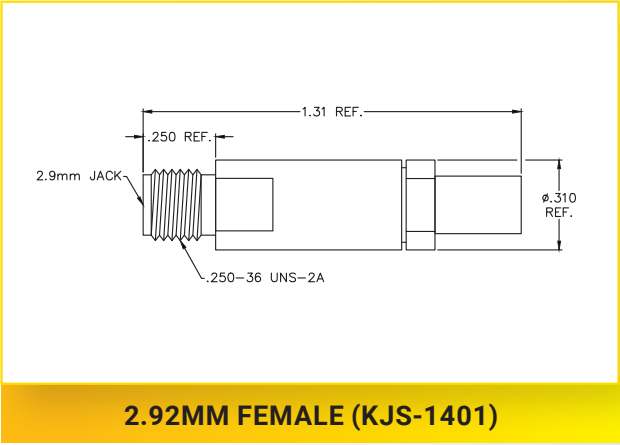

2.92MM FEMALE (KJS-1401)

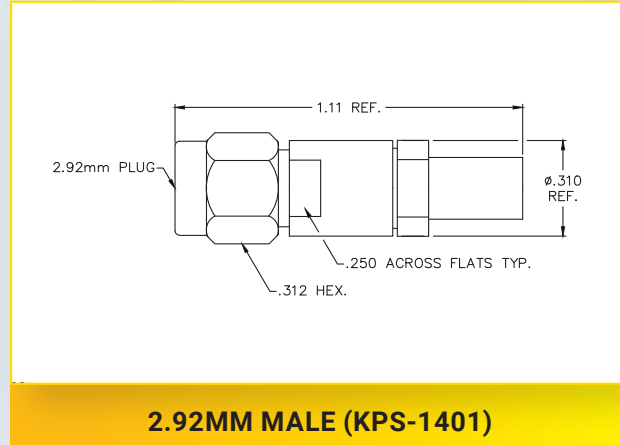

2.92MM MALE (KPS-1401)

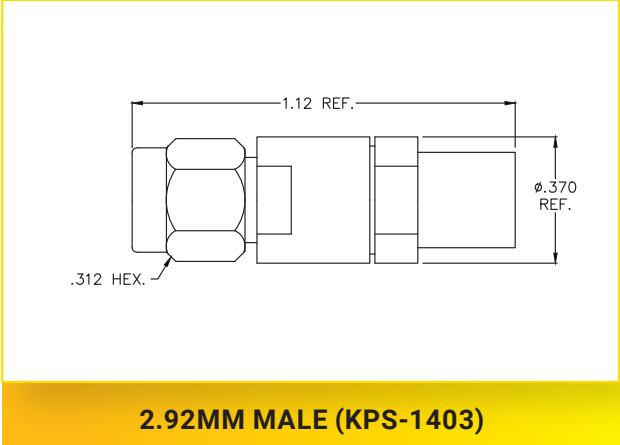

2.92MM MALE (KPS-1403)



150 SERIES

OPERATING UP TO 43 GHz

150 SERIES

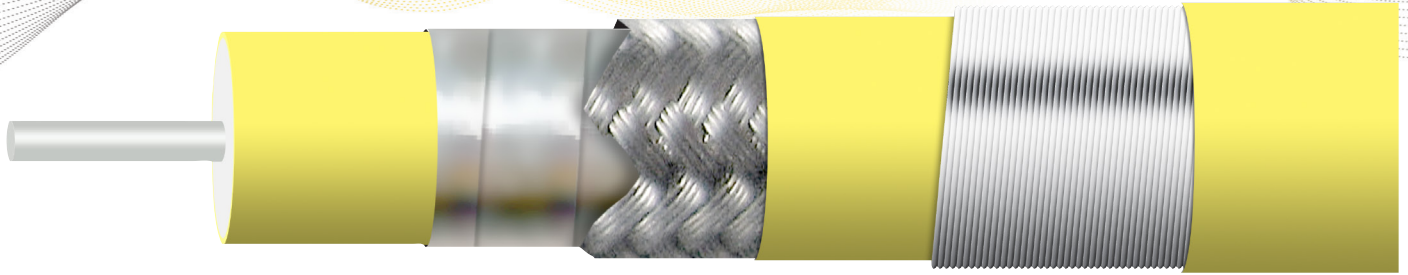

Center Conductor
Silver Plated Copper
1501/1503 Solid
1506/1508 Stranded

Dielectric
EPTFE

Foil
Silver Plated
Copper

Braid
Silver Plated
Copper

Inner Jacket
FEP
(0.144", 3.65mm)

Serving
SCCS Armor

Outer Jacket
FEP
(0.201", 5.11mm)

CABLE SPECIFICATIONS

	1501	1506	1503	1508
ELECTRICAL CHARACTERISTICS				
Impedance	50 +/- 2Ω	50 +/- 2Ω	50 +/- 2Ω	50 +/- 2Ω
Cut Off Frequency (cable only, max)	43 GHz	42 GHz	43 GHz	42 GHz
Capacitance	25.4 pF/ft.	25.4 pF/ft.	25.4 pF/ft.	25.4 pF/ft.
Velocity of Propagation	80%	80%	80%	80%
Time Delay	1.27 ns/ft.	1.27 ns/ft.	1.27 ns/ft.	1.27 ns/ft.
Shielding Effectiveness up to 18GHz	>100 dB	>100 dB	>100 dB	>100 dB
Cable Attenuation Factors (K1, K2) *	10.7, 0.182	12.3, 0.182	10.7, 0.182	12.3, 0.182
Power Handling	See Chart	See Chart	See Chart	See Chart
MECHANICAL CHARACTERISTICS				
Weight	0.36 oz/ft (33g/m)	0.34 oz/ft (31g/m)	0.75 oz/ft (70g/m)	0.73 oz/ft (68g/m)
Static Bend Radius	0.5" (12.7mm)	0.5" (12.7mm)	0.75" (19.1mm)	0.75" (19.1mm)
Dynamic Bend Radius	1.25" (32mm)	1.0" (25.4mm)	1.75" (44.5mm)	1.0" (25.4mm)
ENVIRONMENTAL CHARACTERISTICS				
Operating Temperature Range ¹	-65°C to +200°C	-65°C to +200°C	-65°C to +200°C	-65°C to +200°C
RoHS 3 (EU 2015/863)	Yes	Yes	Yes	Yes

¹ Standard cable assembly temperature range is -55°C to +165°C, -65°C to +200°C available for select configurations

VSWR for assemblies with two straight 2.9 mm connectors

1.35 : 1 to 40 GHz

1.35 : 1 to 40 GHz

1.35 : 1 to 40 GHz

1.35 : 1 to 40 GHz

*Attenuation = $K1\sqrt{f} + K2f$ (cable only)



150 SERIES

OPERATING UP TO 43 GHz

CABLE ATTENUATION

ATTENUATION (MAX)

1501/1503

1506/1508

GHz	dB/ft.	dB/m	Power(W) @ 20°C @ Sea Level	dB/ft.	dB/m	Power(W) @ 20°C @ Sea Level
0.5	0.08	0.25	727	0.09	0.29	650
1	0.11	0.36	500	0.12	0.41	446
2	0.15	0.51	370	0.18	0.58	330
4	0.22	0.73	260	0.25	0.83	232
6	0.27	0.90	210	0.31	1.02	188
8	0.32	1.04	180	0.36	1.19	161
10	0.36	1.17	160	0.41	1.34	143
12	0.39	1.29	150	0.45	1.47	134
14	0.43	1.40	140	0.49	1.59	125
16	0.46	1.50	125	0.52	1.71	112
18	0.49	1.60	120	0.55	1.82	107
20	0.51	1.69	115	0.59	1.92	103
22	0.54	1.78	110	0.62	2.02	98
24	0.57	1.86	105	0.65	2.12	94
26	0.59	1.94	100	0.67	2.21	89
28	0.62	2.02	99	0.70	2.30	88
30	0.64	2.10	97	0.73	2.39	87
32	0.66	2.17	95	0.75	2.47	85
34	0.69	2.25	90	0.78	2.56	80
36	0.71	2.32	85	0.80	2.64	76
38	0.73	2.39	80	0.83	2.71	71
40	0.75	2.46	75	0.85	2.79	67

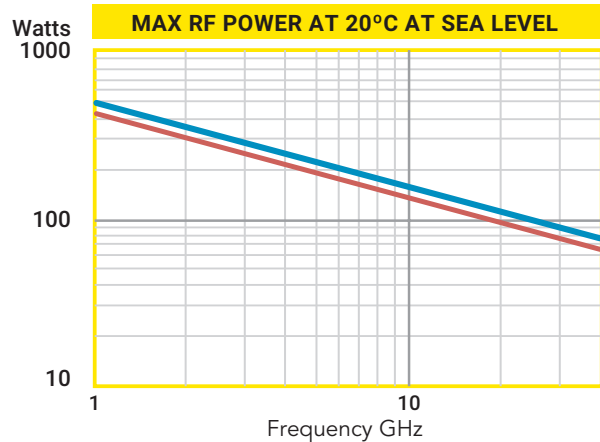
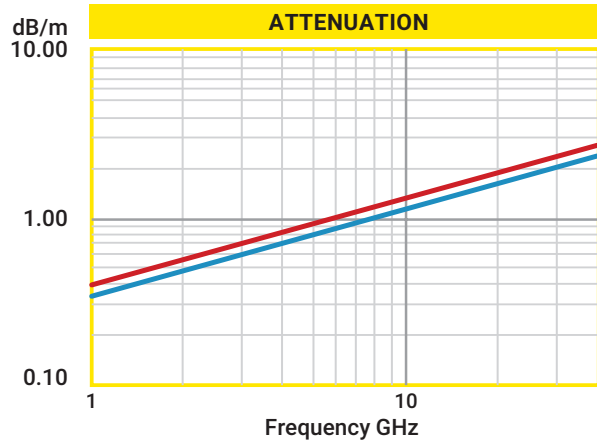
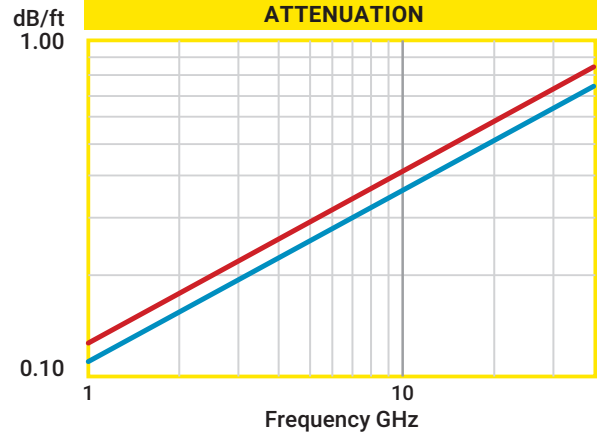



CONNECTORS FOR 150 SERIES

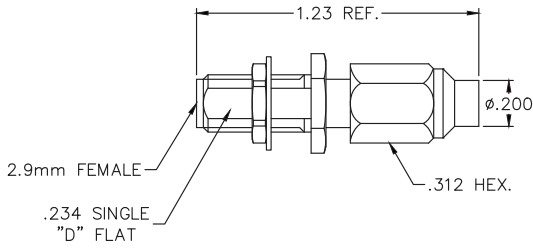

2.92MM FEMALE BULKHEAD (KJB-1501)

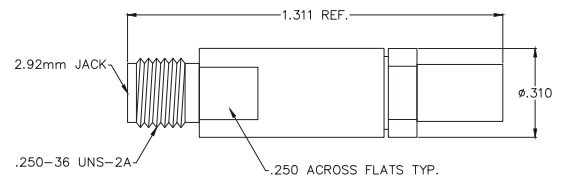

2.92MM FEMALE (KJS-1501)

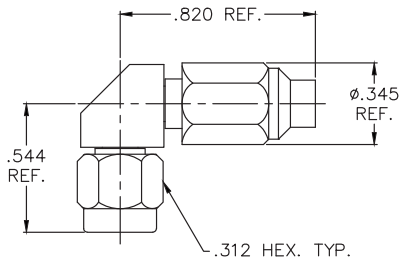

2.92MM RIGHT ANGLE MALE (KPR-1501)

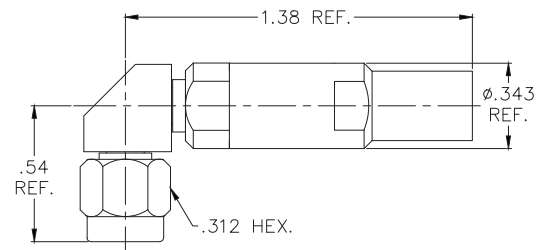

2.92MM RIGHT ANGLE MALE (KPR-1503)

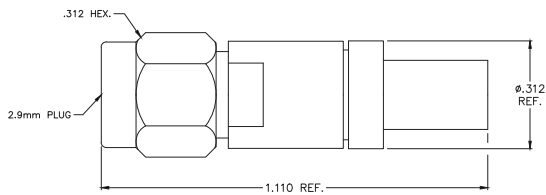

2.92MM MALE (KPS-1501)

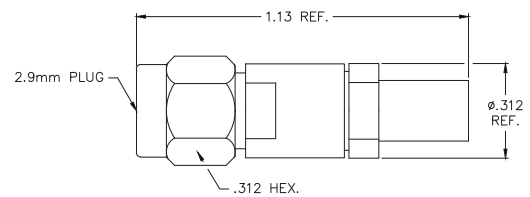

**2.92MM MALE FOR
EXTERNAL ARMOR KPS-1501A**

Other connector types and styles are available, please contact the factory



CONNECTORS FOR 150 SERIES

150 SERIES

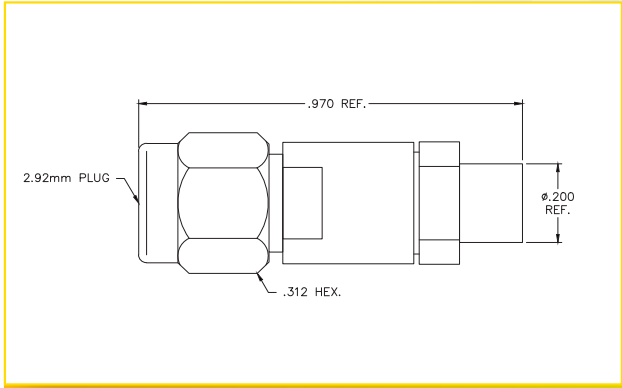

2.92MM MALE, LC JACKET (KPS-1501LC)

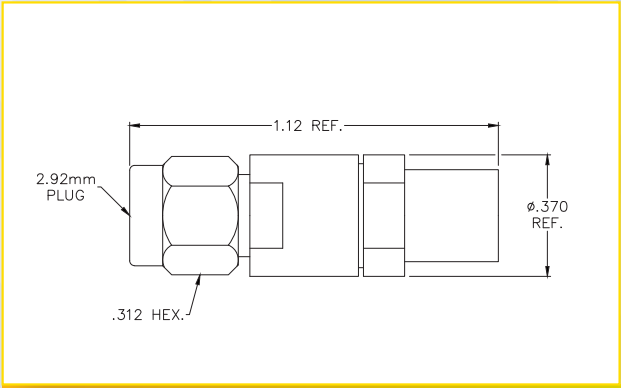

2.92MM MALE (KPS-1503)

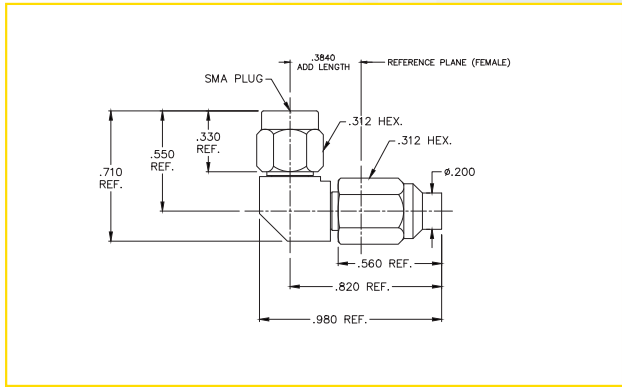

SMA MALE RIGHT ANGLE (SPRC-1501)

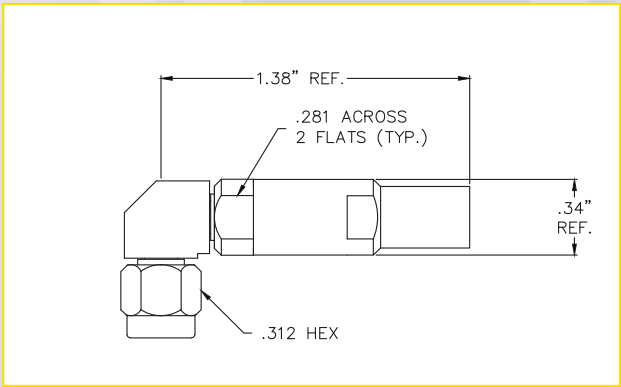

SMA MALE RIGHT ANGLE (SPRC-1503)

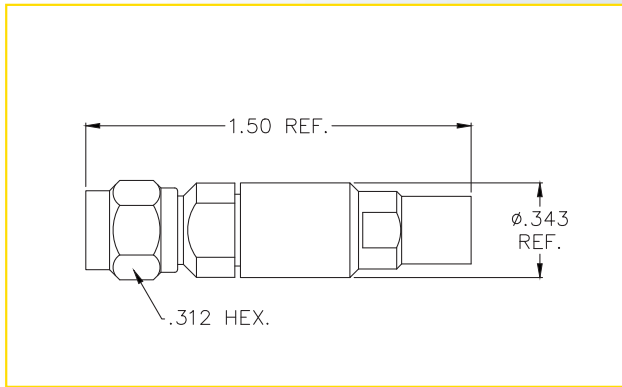

SMA MALE (SPS-1501)

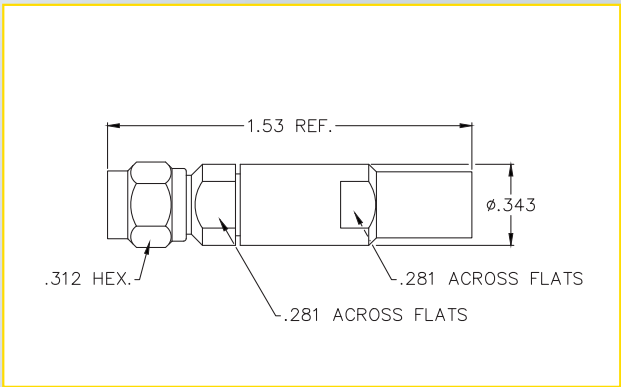

SMA MALE (SPS-1503)

Other connector types and styles are available, please contact the factory



157 SERIES

OPERATING UP TO 40 GHz

157 SERIES

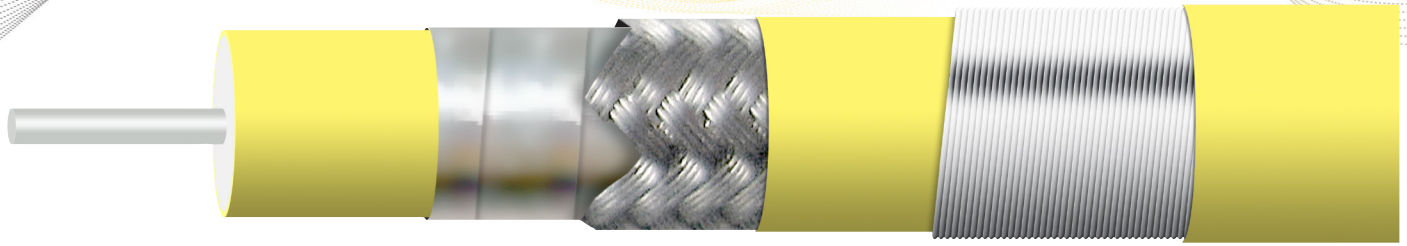

Center Conductor
Silver Plated Copper

Dielectric
EPTFE

Foil
Silver Plated
Copper

Braid
Silver Plated
Copper

Inner Jacket
FEP
(0.155", 3.94mm)

Serving
SCCS Armor

Outer Jacket
FEP
(0.213", 5.41mm)

CABLE SPECIFICATIONS

	1571	1573
ELECTRICAL CHARACTERISTICS		
Impedance	50 +/- 2Ω	50 +/- 2Ω
Cut Off Frequency (cable only, max)	41.5 GHz	41.5 GHz
Capacitance	24.5 pF/ft.	24.5 pF/ft.
Velocity of Propagation	80%	80%
Time Delay	1.27 ns/ft.	1.27 ns/ft.
Shielding Effectiveness up to 18GHz	>90 dB	>90 dB
Cable Attenuation Factors (K1, K2) *	9.3, 0.18	9.3, 0.18
Power Handling	See Chart	See Chart
MECHANICAL CHARACTERISTICS		
Weight	.42 oz/ft (38.5g/m)	.96oz/ft (89.3 g/m)
Static Bend Radius	0.5" (12.7mm)	0.75" (19.05mm)
Dynamic Bend Radius	1.25" (31.75mm)	1.5" (38.10mm)
ENVIRONMENTAL CHARACTERISTICS		
Operating Temperature Range ¹	-65°C to +200°C	-65°C to +200°C
RoHS 3 (EU 2015/863)	Yes	Yes

¹ Standard cable assembly temperature range is -55°C to +165°C, -65°C to +200°C available for select configurations

VSWR for assemblies with two straight connectors

1.35:1 to 40 GHz

1.35:1 to 40 GHz

*Attenuation = $K1\sqrt{f} + K2f$ (cable only)



157 SERIES

OPERATING UP TO 40 GHz

CABLE ATTENUATION

ATTENUATION (MAX)

1571/1573

GHz	dB/ft.	dB/m	Power(W) @ 20°C @ Sea Level
0.5	0.07	0.22	727
1	0.09	0.31	500
2	0.14	0.44	370
4	0.19	0.63	260
6	0.24	0.78	210
8	0.28	0.91	180
10	0.31	1.02	160
12	0.34	1.13	150
14	0.37	1.22	140
16	0.40	1.31	125
18	0.43	1.40	120
20	0.45	1.48	115
22	0.48	1.56	110
24	0.50	1.64	105
26	0.52	1.71	100
28	0.54	1.78	99
30	0.56	1.85	97
32	0.58	1.91	95
34	0.60	1.98	90
36	0.62	2.04	85
38	0.64	2.10	80
40	0.66	2.16	75

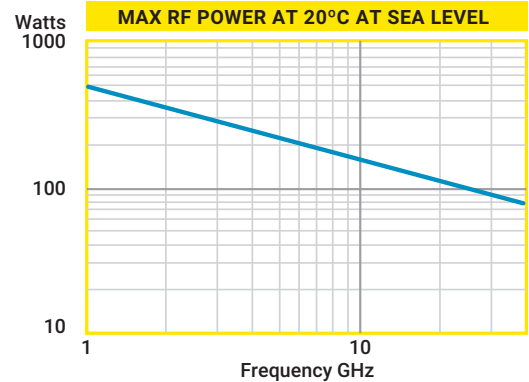
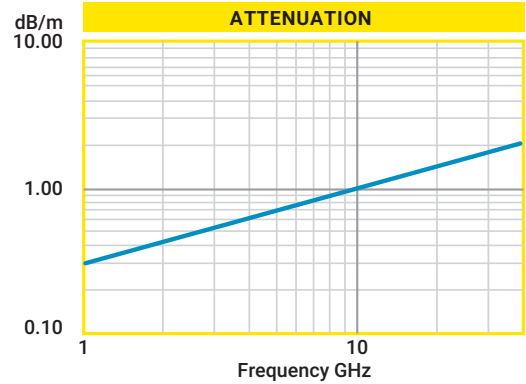
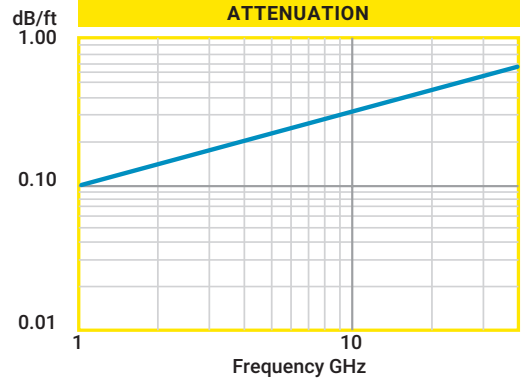

CONNECTORS FOR 157 SERIES

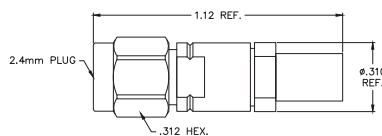

2.4MM MALE (2PS-1571)

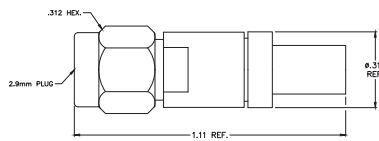

2.92MM MALE (KPS-1571)

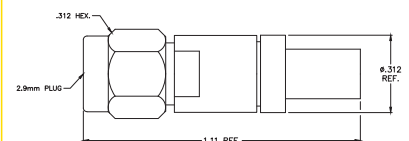

2.92MM MALE (KPS-1571)



160 SERIES

OPERATING UP TO 34 GHz

160 SERIES

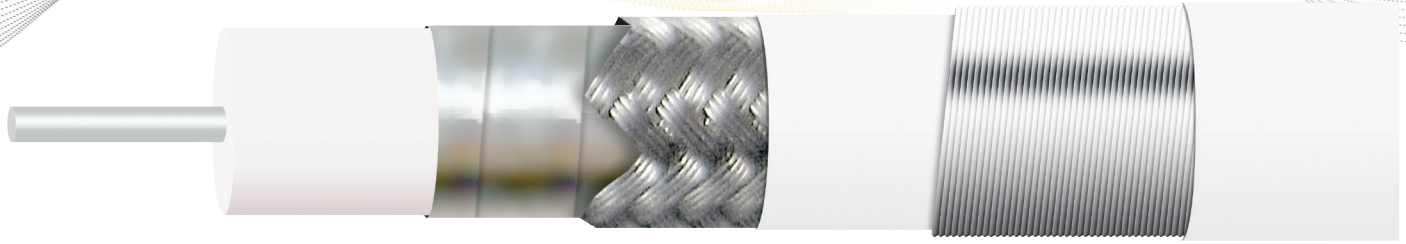

Center Conductor
Silver Plated Copper
1601/1603 Solid
1606/1608 Stranded

Dielectric
EPTFE

Foil
Silver Plated
Copper

Braid
Silver Plated
Copper

Inner Jacket
FEP
(0.160", 4.8mm)

Serving
SCCS Armor

Outer Jacket
FEP
(0.218", 5.5mm)

CABLE SPECIFICATIONS

	1601	1606	1603	1608
ELECTRICAL CHARACTERISTICS				
Impedance	50 +/- 2Ω	50 +/- 2Ω	50 +/- 2Ω	50 +/- 2Ω
Cut Off Frequency (cable only, max)	34 GHz	34 GHz	34 GHz	34 GHz
Capacitance	28.6 pF/ft.	28.6 pF/ft.	28.6 pF/ft.	28.6 pF/ft.
Velocity of Propagation	71%	71%	71%	71%
Time Delay	1.43 ns/ft.	1.43 ns/ft.	1.43 ns/ft.	1.43 ns/ft.
Shielding Effectiveness up to 18GHz	>90 dB	>90 dB	>90 dB	>90 dB
Cable Attenuation Factors (K1, K2) *	10.9, 0.89	12.2, 0.89	10.9, 0.89	12.2, 0.89
Power Handling	See Chart	See Chart	See Chart	See Chart
MECHANICAL CHARACTERISTICS				
Weight	.5 oz/ft (46 g/m)	.5 oz/ft (46 g/m)	1.0 oz/ft (97 g/m)	.98 oz/ft (92 g/m)
Static Bend Radius	0.375" (9.52 mm)	0.375" (9.52 mm)	0.675" (17.14mm)	0.625" (15.87mm)
Dynamic Bend Radius	1.0"(25.4mm)	1.0" (25.4mm)	1.5" (38.1mm)	1.5" (38.1 mm)
ENVIRONMENTAL CHARACTERISTICS				
Operating Temperature Range ¹	-65°C to +200°C	-65°C to +200°C	-65°C to +200°C	-65°C to +200°C
RoHS 3 (EU 2015/863)	Yes	Yes	Yes	Yes

¹ Standard cable assembly temperature range is -55°C to +165°C, -65°C to +200°C available for select configurations

VSWR for assemblies with two straight connectors	1.35:1 to 18 GHz	1.35:1 to 18 GHz	1.35:1 to 18 GHz	1.35:1 to 18 GHz
VSWR for assemblies with one straight and one right angle connector	1.40:1 to 18 GHz	1.40:1 to 18 GHz	1.40:1 to 18 GHz	1.40:1 to 18 GHz
VSWR for assemblies with two right angle connectors	1.45:1 to 18 GHz	1.45:1 to 18 GHz	1.45:1 to 18 GHz	1.45:1 to 18 GHz

*Attenuation = $K1\sqrt{f} + K2f$ (cable only)

1601 is a flexible replacement for RG402 cable



160 SERIES

OPERATING UP TO 34 GHz

CABLE ATTENUATION

ATTENUATION (MAX)

GHz	1601/1603			1606/1608		
	dB/ft.	dB/m	Power(W) @ 20°C @ Sea Level	dB/ft.	dB/m	Power(W) @ 20°C @ Sea Level
0.5	0.08	0.27	707	0.09	0.30	632
1	0.12	0.39	500	0.13	0.43	446
2	0.17	0.56	350	0.19	0.62	313
4	0.25	0.83	240	0.28	0.92	214
6	0.32	1.05	190	0.35	1.16	170
8	0.38	1.25	160	0.42	1.37	143
10	0.43	1.42	150	0.47	1.56	134
12	0.48	1.59	140	0.53	1.74	125
14	0.53	1.75	130	0.58	1.91	116
16	0.58	1.90	120	0.63	2.07	107
18	0.62	2.04	110	0.68	2.22	98
20	0.64	2.11	100	0.72	2.36	89
22	0.68	2.25	90	0.77	2.52	80
24	0.73	2.38	80	0.81	2.66	71
26	0.77	2.51	70	0.86	2.81	63
28	0.80	2.64	60	0.90	2.95	54
30	0.84	2.76	50	0.94	3.09	45
32	0.88	2.89	40	0.99	3.23	36

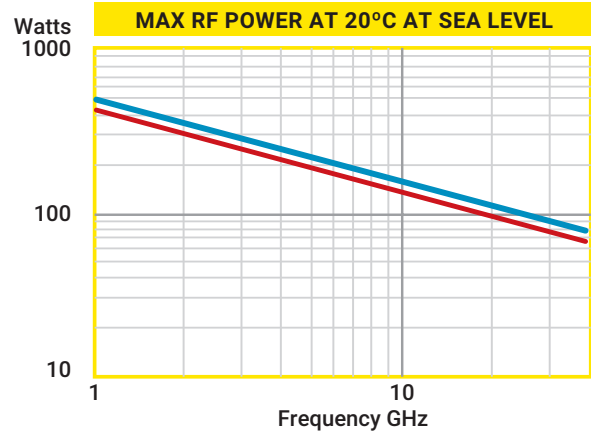
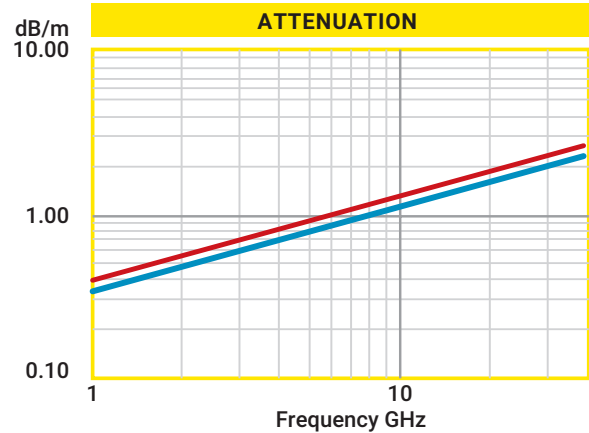
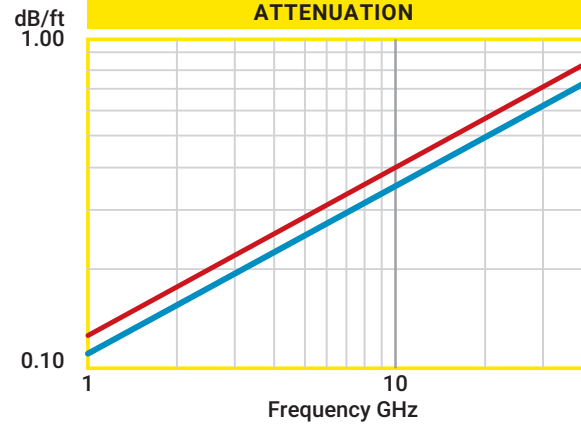



CONNECTORS FOR 160 SERIES

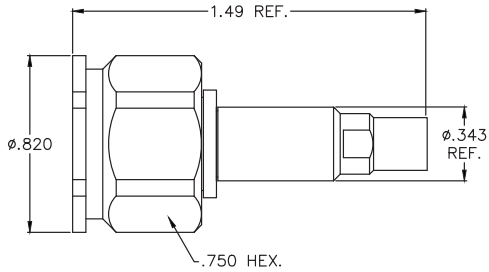

N-TYPE MALE (NPS-1601)

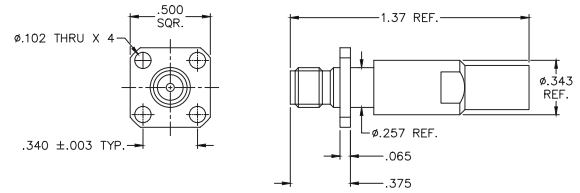

**SMA FEMALE, 4-HOLE
FLANGE MOUNT (SJP4-1601)**

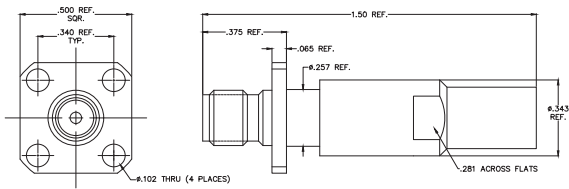

**SMA FEMALE, 4-HOLE
FLANGE MOUNT (SJP4-1603)**

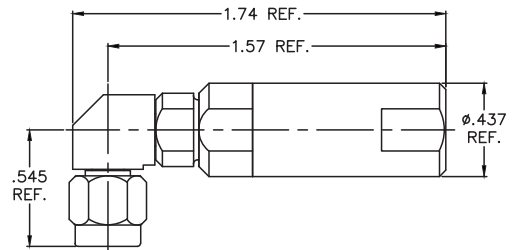

**SMA MALE RIGHT ANGLE FOR
EXTERNAL ARMOR (SPRC-1601A)**

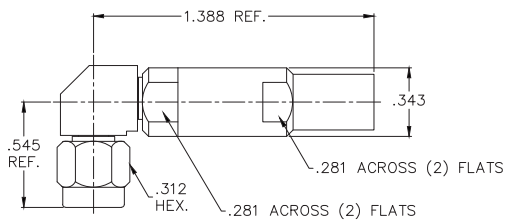

SMA MALE RIGHT ANGLE (SPRC-1603)

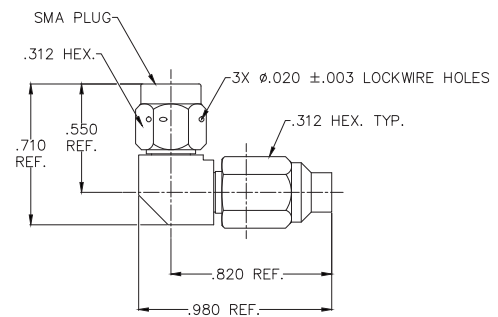

**SMA MALE RIGHT ANGLE W/LOCK
WIRE HOLES (SPRCW-1601)**

Other connector types and styles are available, please contact the factory



CONNECTORS FOR 160 SERIES

160 SERIES

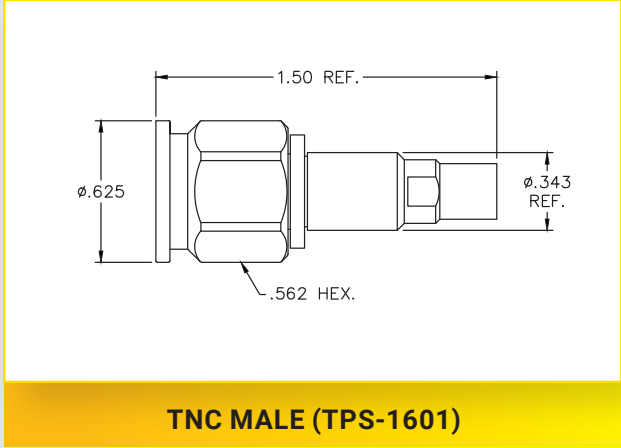
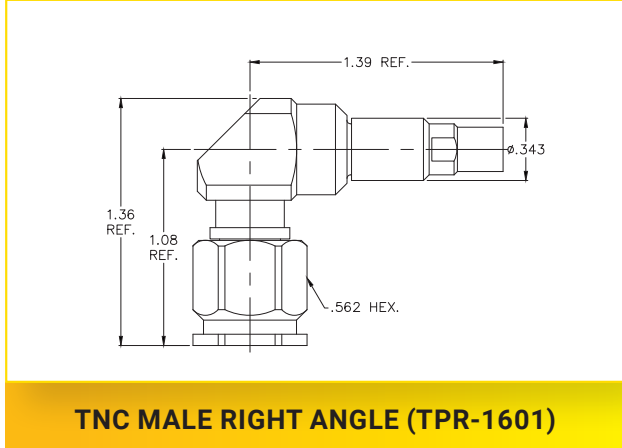
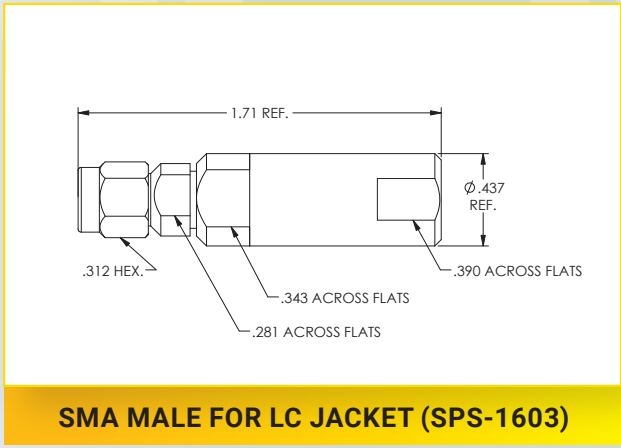
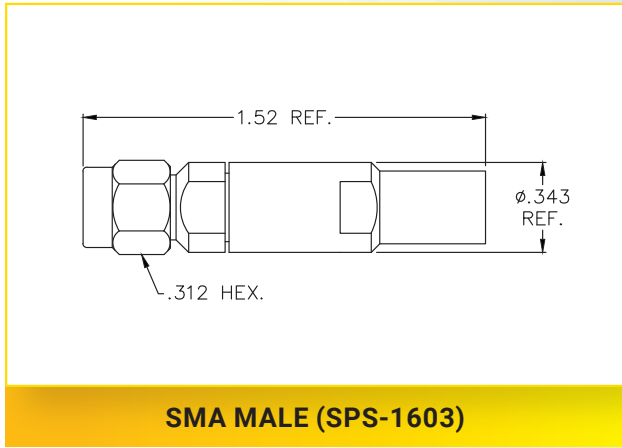
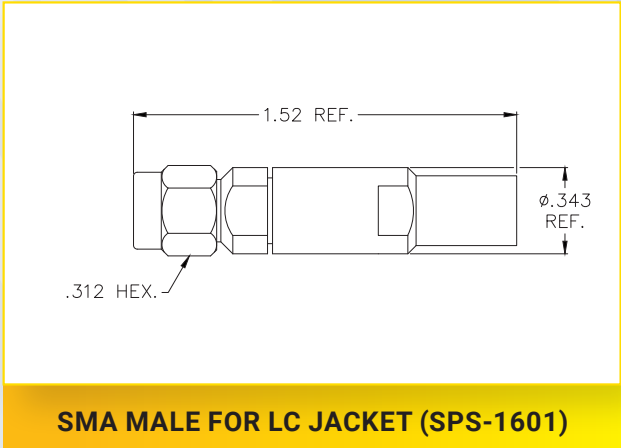
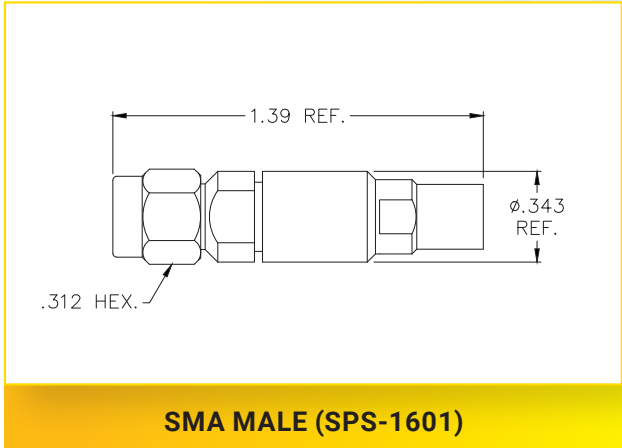

Other connector types and styles are available, please contact the factory



180 SERIES

OPERATING UP TO 32 GHz

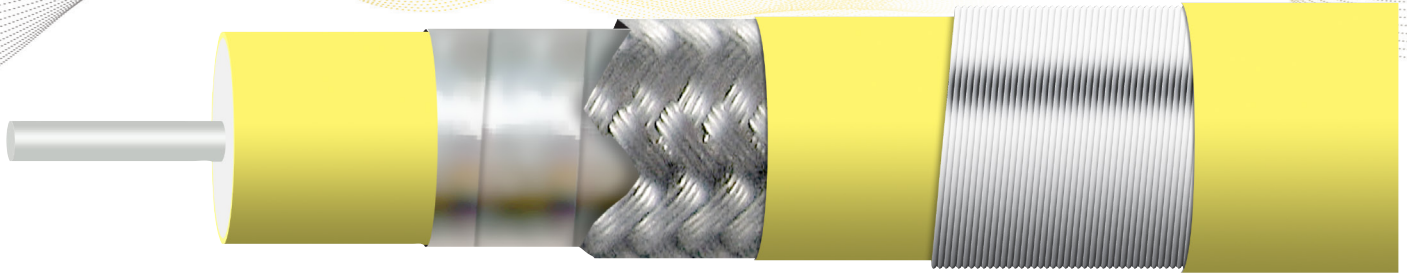

Center Conductor
Silver Plated Copper
1801/1803 Solid
1806/1808 Stranded

Dielectric
EPTFE

Foil
Silver Plated
Copper

Braid
Silver Plated
Copper

Inner Jacket
FEP
(0.188", 4.8mm)

Serving
SCCS Armor

Outer Jacket
FEP
(0.260", 6.6mm)

CABLE SPECIFICATIONS

	1801	1806	1803	1808
ELECTRICAL CHARACTERISTICS				
Impedance	50 +/- 2Ω	50 +/- 2Ω	50 +/- 2Ω	50 +/- 2Ω
Cut Off Frequency (cable only, max)	32 GHz	32 GHz	32 GHz	32 GHz
Capacitance	24.5 pF/ft.	24.5 pF/ft.	24.5 pF/ft.	24.5 pF/ft
Velocity of Propagation	83%	83%	83%	83%
Time Delay	1.22 ns/ft.	1.22 ns/ft.	1.22 ns/ft.	1.22 ns/ft.
Shielding Effectiveness up to 18GHz	>90 dB	>90 dB	>90 dB	>90 dB
Cable Attenuation Factors (K1, K2) *	7.8, 0.165	9.0, 0.190	7.8, 0.165	9.0, 0.190
Power Handling	See Chart	See Chart	See Chart	See Chart
MECHANICAL CHARACTERISTICS				
Weight	.59 oz/ft (55 g/m)	.56 oz/ft (52 g/m)	1.39 oz/ft (129 g/m)	1.34 oz/ft (92 g/m)
Static Bend Radius	0.75" (19mm)	0.625" (15.9mm)	0.875" (22.2mm)	0.875" (22.2mm)
Dynamic Bend Radius	1.25" (31.75mm)	1.25" (31.75 mm)	1.75" (44.5mm)	1.75" (44.5mm)
ENVIRONMENTAL CHARACTERISTICS				
Operating Temperature Range ¹	-65°C to +200°C	-65°C to +200°C	-65°C to +200°C	-65°C to +200°C
RoHS 3 (EU 2015/863) Yes	Yes	Yes	Yes	Yes

¹ Standard cable assembly temperature range is -55°C to +165°C, -65°C to +200°C available for select configurations

VSWR for assemblies with two straight connectors	1.35:1 to 18 GHz	1.35:1 to 18 GHz	1.35:1 to 18 GHz	1.35:1 to 18 GHz
VSWR for assemblies with one straight and one right angle connector	1.40:1 to 18 GHz	1.40:1 to 18 GHz	1.40:1 to 18 GHz	1.40:1 to 18 GHz
VSWR for assemblies with two right angle connectors	1.45:1 to 18 GHz	1.45:1 to 18 GHz	1.45:1 to 18 GHz	1.45:1 to 18 GHz
VSWR for assemblies with two straight 3.5mm connectors	1.35:1 to 26.5 GHz	1.35:1 to 26.5 GHz	1.35:1 to 26.5 GHz	1.35:1 to 26.5 GHz

*Attenuation = $K1\sqrt{f} + K2f$ (cable only)



180 SERIES

OPERATING UP TO 32 GHz

CABLE ATTENUATION

ATTENUATION (MAX)

GHz	1801/1803			1806/1808		
	dB/ft.	dB/m	Power(W) @ 20°C @ Sea Level	dB/ft.	dB/m	Power(W) @ 20°C @ Sea Level
0.5	0.06	0.18	1044	0.06	0.21	931
1	0.08	0.26	800	0.09	0.30	714
2	0.11	0.37	550	0.13	0.43	491
4	0.16	0.53	400	0.19	0.61	357
6	0.20	0.66	320	0.23	0.75	286
8	0.23	0.77	290	0.27	0.88	259
10	0.26	0.86	250	0.30	0.99	223
12	0.29	0.95	220	0.33	1.09	196
14	0.31	1.03	210	0.36	1.18	188
16	0.34	1.11	200	0.39	1.27	179
18	0.36	1.18	195	0.42	1.35	174
20	0.38	1.25	190	0.44	1.44	170
22	0.40	1.32	185	0.46	1.52	165
24	0.42	1.38	180	0.49	1.60	161
26	0.44	1.45	175	0.51	1.67	156
28	0.46	1.51	170	0.53	1.74	152
30	0.48	1.56	160	0.55	1.80	143
31	0.49	1.59	155	0.56	1.87	138
32	0.49	1.62	150	0.57	1.87	136

dB/ft
1.00

ATTENUATION

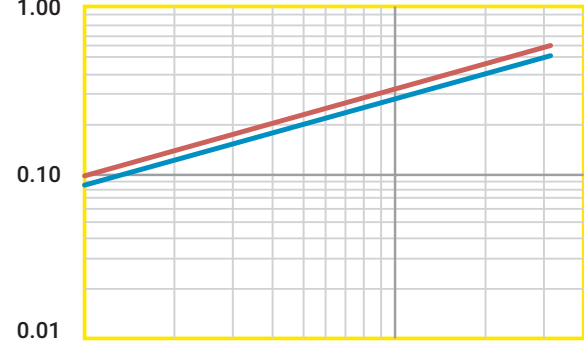

dB/m
10.00

ATTENUATION

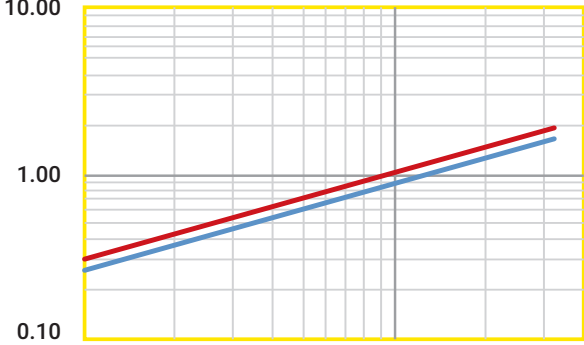

Watts
1000

MAX RF POWER AT 20°C AT SEA LEVEL

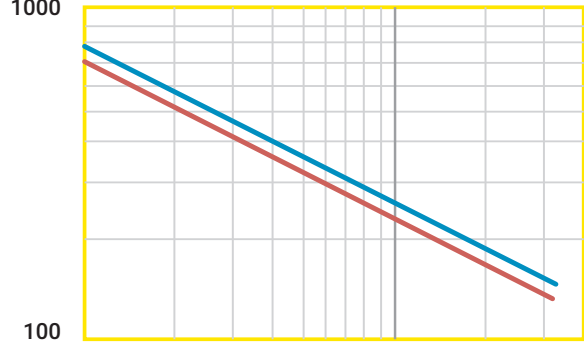



CONNECTORS FOR 180 SERIES

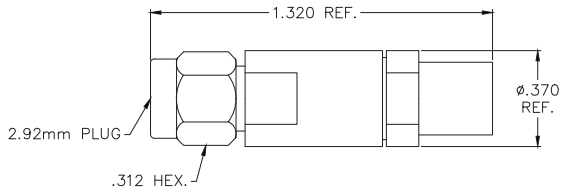

2.92MM MALE (KPS-1801)

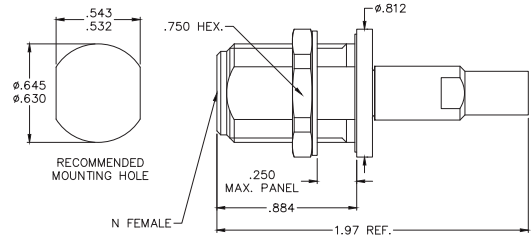

N-TYPE FEMALE BULKHEAD (NJB-1801)

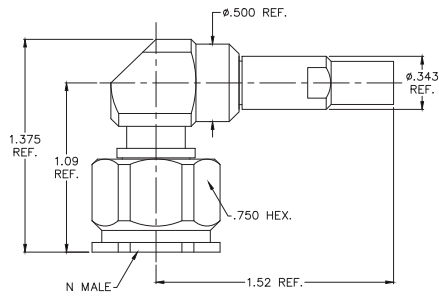

N-TYPE MALE RIGHT ANGLE (NPR-1801)

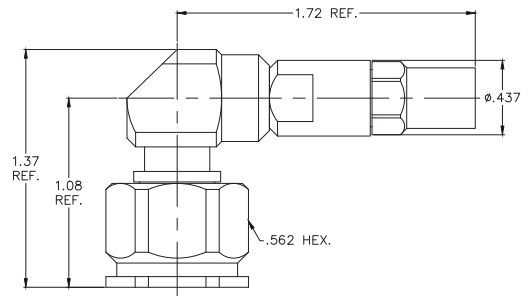

N-TYPE MALE RIGHT ANGLE (NPR-1803)

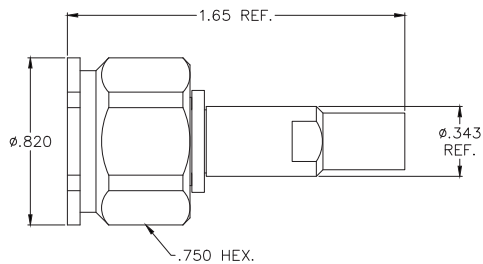

N-TYPE MALE (NPS-1801)

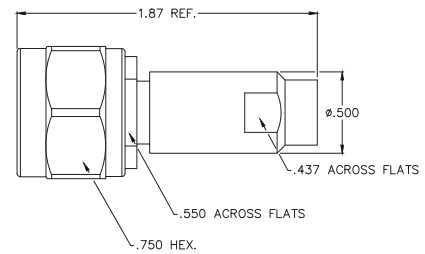

N-TYPE MALE (NPS-1803)

Other connector types and styles are available, please contact the factory



CONNECTORS FOR 180 SERIES

180 SERIES

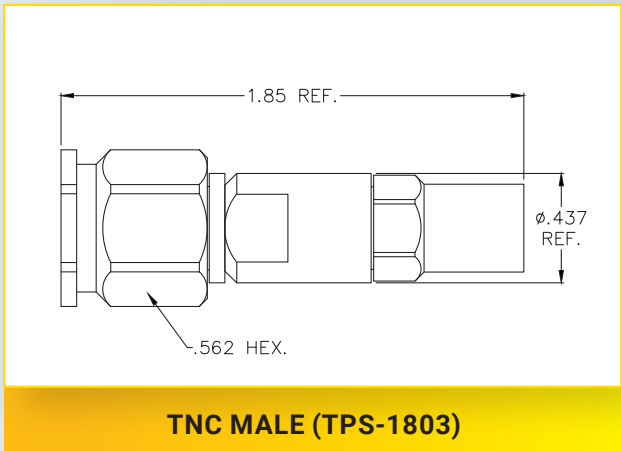
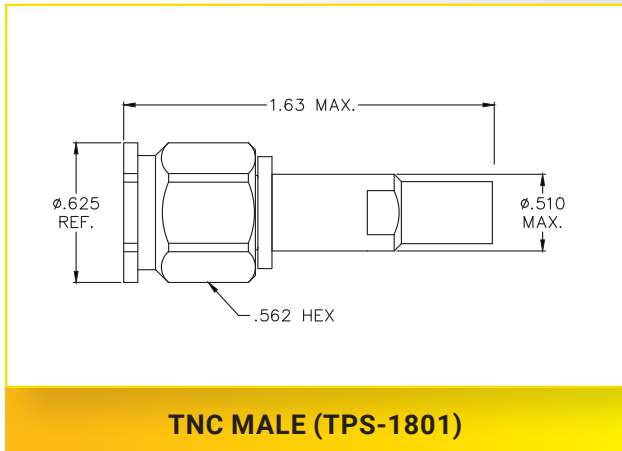
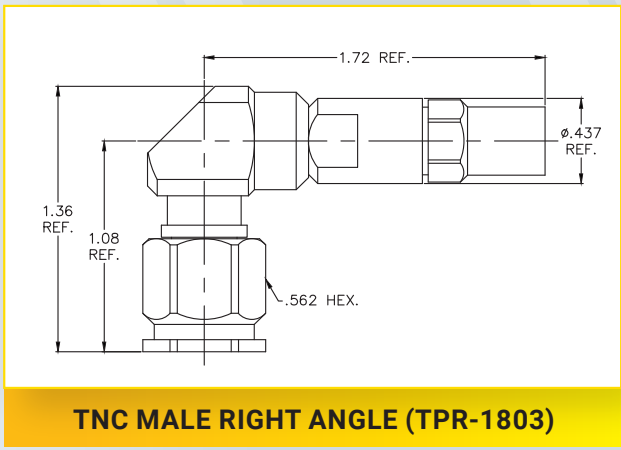
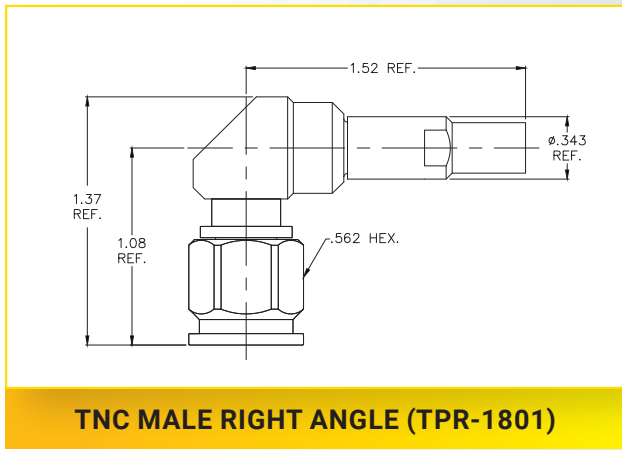
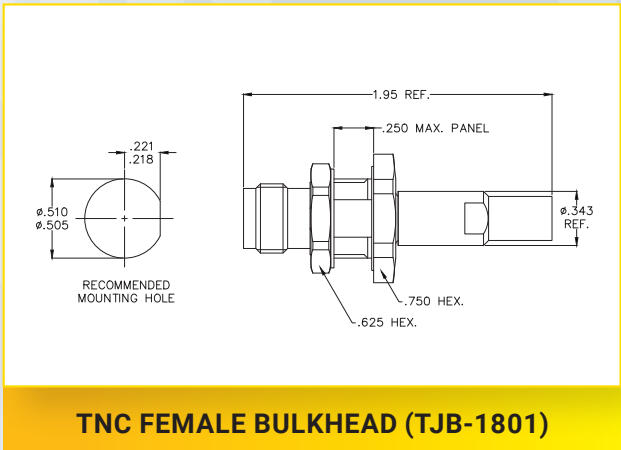
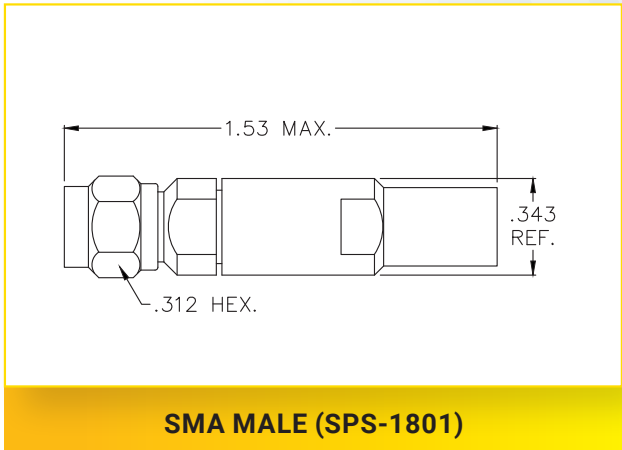

Other connector types and styles are available, please contact the factory



230 SERIES

OPERATING UP TO 26.5 GHz

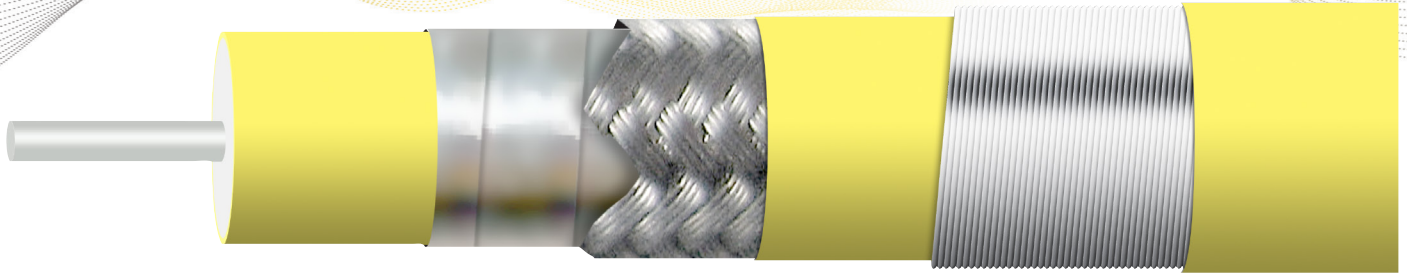

Center Conductor
Silver Plated Copper
2301/2303 Solid
2306/2308 Stranded

Dielectric
EPTFE

Foil
Silver Plated
Copper

Braid
Silver Plated
Copper

Inner Jacket
FEP
(0.222", 5.79mm)

Serving
SCCS Armor

Outer Jacket
FEP
(0.292", 7.42mm)

CABLE SPECIFICATIONS

	2301	2306	2303	2308
ELECTRICAL CHARACTERISTICS				
Impedance	50 +/- 2Ω	50 +/- 2Ω	50 +/- 2Ω	50 +/- 2Ω
Cut Off Frequency (cable only, max)	26.5 GHz	26.5 GHz	26.5 GHz	26.5GHz
Capacitance	24.2 pF/ft.	24.2 pF/ft.	24.2 pF/ft.	24.2 pF/ft.
Velocity of Propagation	83%	83%	83%	83%
Time Delay	1.21 ns/ft.	1.21 ns/ft.	1.21 ns/ft.	1.21 ns/ft.
Shielding Effectiveness up to 18GHz	>100 dB	>100 dB	>100 dB	>90 dB
Cable Attenuation Factors (K1, K2) *	6.0, 0.176	7.4, 0.179	6.0, 0.176	7.4, 0.179
Power Handling	See Chart	See Chart	See Chart	See Chart
MECHANICAL CHARACTERISTICS				
Weight	0.77 oz/ft (72g/m)	.74 oz/ft (68 g/m)	1.7 oz/ft (156 g/m)	1.58 oz/ft (147 g/m)
Static Bend Radius	0.75" (19.05mm)	0.625" (15.9mm)	1" (25.4mm)	0.875" (22.2mm)
Dynamic Bend Radius	1.375" (34.9mm)	1.25" (31.8mm)	2" (50.8mm)	1.75" (44.5mm)
ENVIRONMENTAL CHARACTERISTICS				
Operating Temperature Range ¹	-65°C to +200°C	-65°C to +200°C	-65°C to +200°C	-65°C to +200°C
RoHS 3 (EU 2015/863)	Yes	Yes	Yes	Yes

¹ Standard cable assembly temperature range is -55°C to +165°C, -65°C to +200°C available for select configurations

VSWR for assemblies with two straight connectors	1.35:1 to 18 GHz	1.35:1 to 18 GHz	1.35:1 to 18 GHz	1.35:1 to 18 GHz
VSWR for assemblies with one straight and one right angle connector	1.40:1 to 18 GHz	1.40:1 to 18 GHz	1.40:1 to 18 GHz	1.40:1 to 18 GHz
VSWR for assemblies with two right angle connectors	1.45:1 to 18 GHz	1.45:1 to 18 GHz	1.45:1 to 18 GHz	1.45:1 to 18 GHz
VSWR for assemblies with two straight 3.5mm connectors	1.35:1 to 26.5 GHz	1.35:1 to 26.5 GHz	1.35:1 to 26.5 GHz	1.35:1 to 26.5 GHz

*Attenuation = $K1\sqrt{f} + K2f$ (cable only)



230 SERIES

OPERATING UP TO 26.5 GHz

CABLE ATTENUATION

ATTENUATION (MAX)

GHz	2301/2303			2306/2308		
	dB/ft.	dB/m	Power(W) @ 20°C @ Sea Level	dB/ft.	dB/m	Power(W) @ 20°C @ Sea Level
0.5	0.04	0.14	1265	0.05	0.17	1135
1	0.06	0.20	1100	0.08	0.25	982
2	0.09	0.29	800	0.11	0.36	714
4	0.13	0.42	520	0.16	0.51	464
6	0.16	0.52	450	0.19	0.63	402
8	0.18	0.60	380	0.22	0.73	339
10	0.21	0.68	350	0.25	0.83	313
12	0.23	0.75	310	0.28	0.91	277
14	0.25	0.82	300	0.30	0.99	268
16	0.27	0.88	280	0.32	1.07	250
18	0.29	0.94	270	0.35	1.14	241
20	0.30	1.00	250	0.37	1.20	223
22	0.32	1.05	230	0.39	1.27	205
24	0.34	1.10	220	0.41	1.33	196
25	0.34	1.13	215	0.41	1.36	188
26.5	0.36	1.17	210	0.43	1.41	180

dB/ft

ATTENUATION

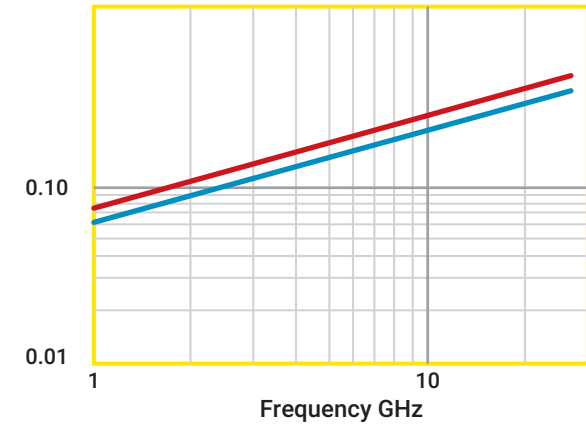

dB/m

ATTENUATION

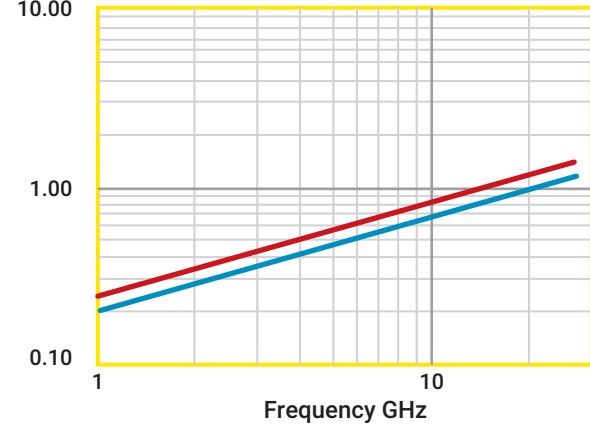

Watts
10,000

MAX RF POWER AT 20°C AT SEA LEVEL

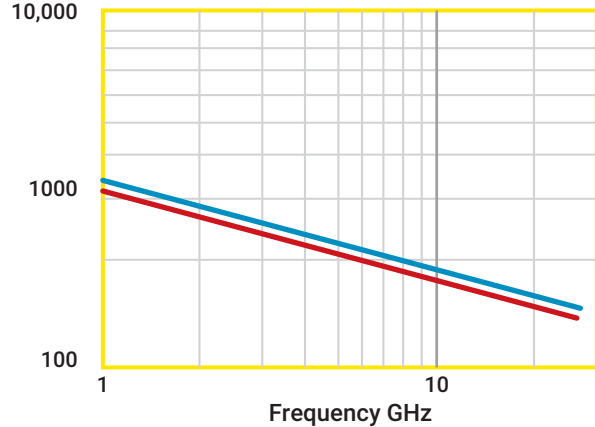



CONNECTORS FOR 230 SERIES

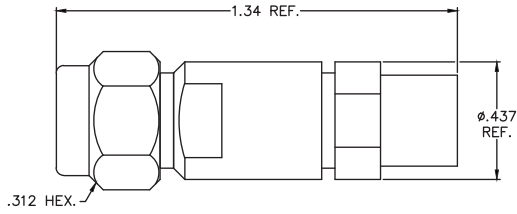

3.5MM MALE (3PS-2301)

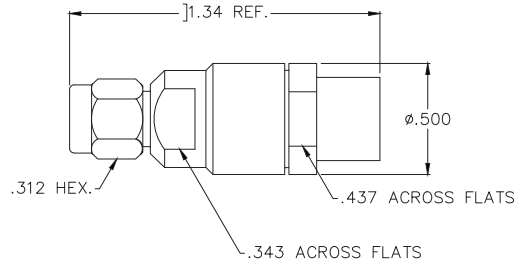

3.5MM MALE (3PS-2303)

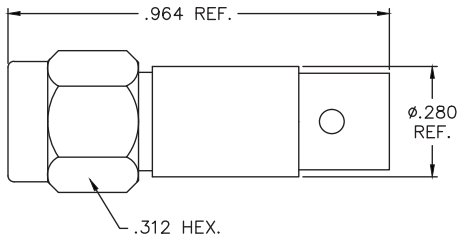

3.5MM MALE DIRECT SOLDER (3PSD-2301)

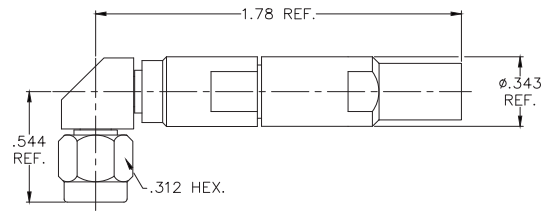

2.92MM MALE RIGHT ANGLE (KPR-2301)

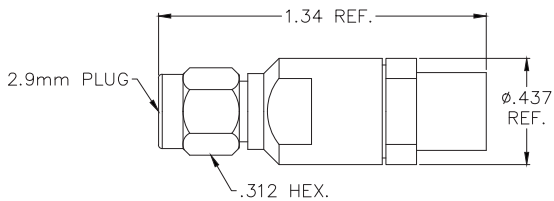

2.92MM MALE (KPS-2301)

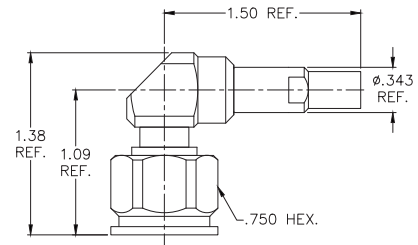

N-TYPE MALE RIGHT ANGLE (NPR-2301)

Other connector types and styles are available, please contact the factory



CONNECTORS FOR 230 SERIES

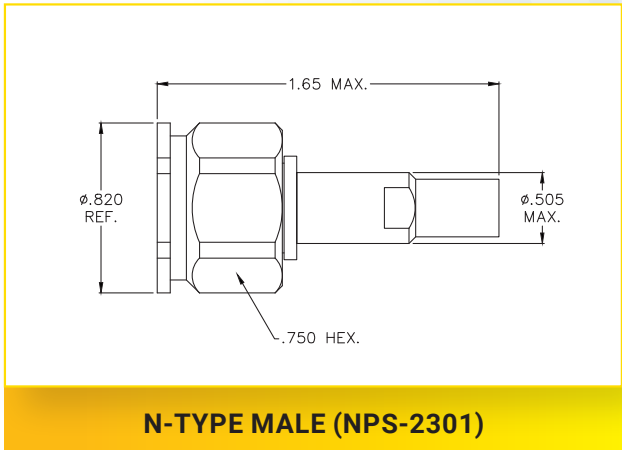

N-TYPE MALE (NPS-2301)

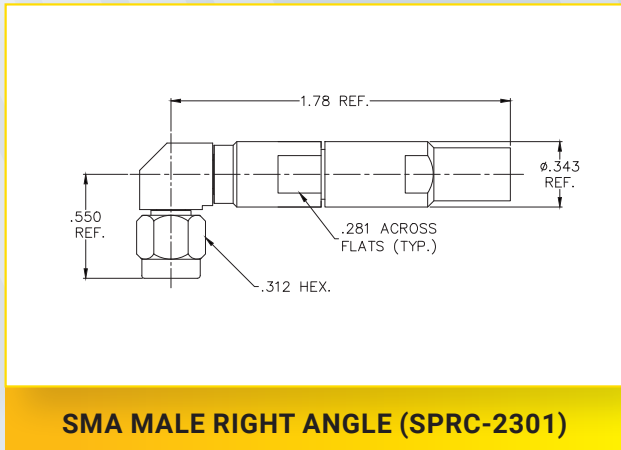

SMA MALE RIGHT ANGLE (SPRC-2301)

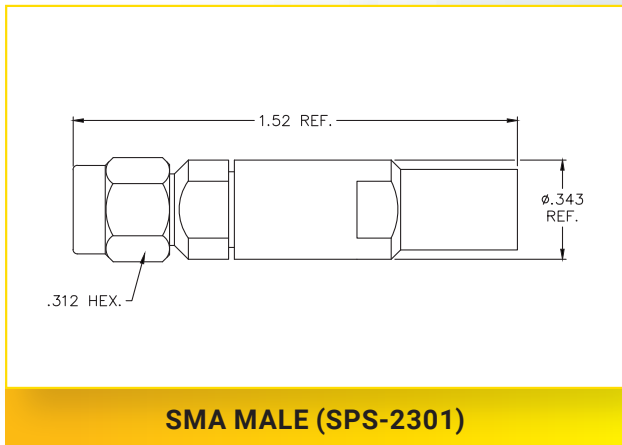

SMA MALE (SPS-2301)

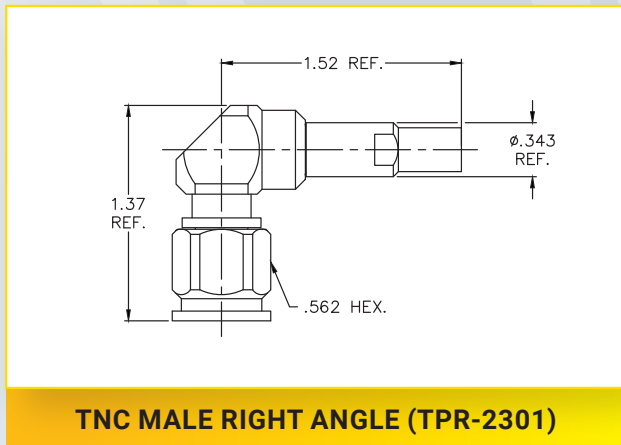

TNC MALE RIGHT ANGLE (TPR-2301)

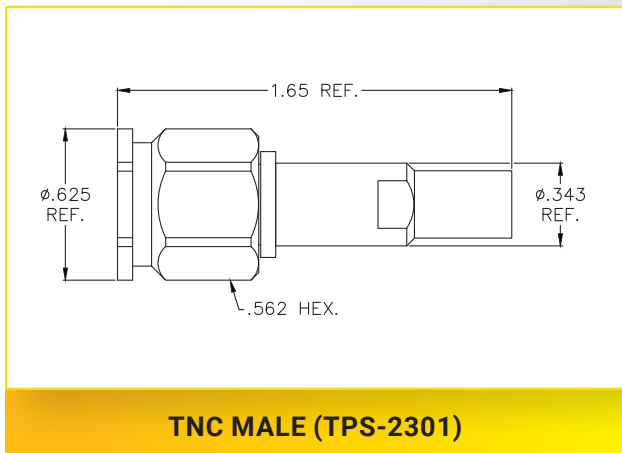

TNC MALE (TPS-2301)

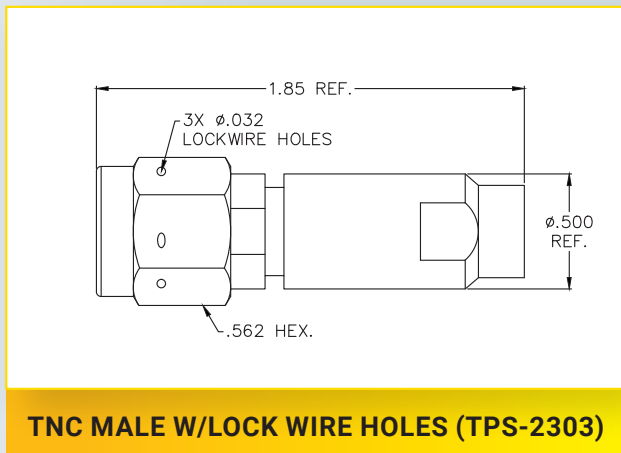

TNC MALE W/LOCK WIRE HOLES (TPS-2303)

Other connector types and styles are available, please contact the factory



280 SERIES

OPERATING UP TO 18 GHz

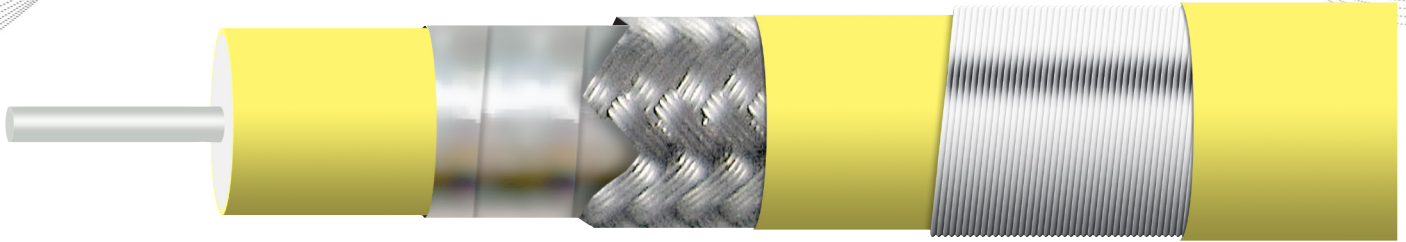

Center Conductor
Silver Plated Copper
2801/2803 Solid
2806/2808 Stranded

Dielectric
EPTFE

Foil
Silver Plated
Copper

Braid
Silver Plated
Copper

Inner Jacket
FEP
(0.303", 7.82mm)

Serving
SCCS Armor

Outer Jacket
FEP
(0.382", 9.70mm)

CABLE SPECIFICATIONS

	2801	2806	2803	2808
ELECTRICAL CHARACTERISTICS				
Impedance	50 +/- 2Ω	50 +/- 2Ω	50 +/- 2Ω	50 +/- 2Ω
Cut Off Frequency (cable only, max)	18.5 GHz	18.5 GHz	18.5 GHz	18.5 GHz
GHzCapacitance	24.5 pF/ft.	24.5 pF/ft.	24.5 pF/ft.	24.5 pF/ft.
Velocity of Propagation	83%	83%	83%	83%
Time Delay	1.22 ns/ft.	1.22 ns/ft.	1.22 ns/ft.	1.22 ns/ft
Shielding Effectiveness up to 18GHz	>100 dB	>100 dB	>100 dB	>90 dB
Cable Attenuation Factors (K1, K2) *	4.3, 0.100	5.4, 0.174	4.3, 0.100	5.4, 0.174
Power Handling	See Chart	See Chart	See Chart	See Chart
MECHANICAL CHARACTERISTICS				
Weight	1.33 oz/ft (123 g/m)	1.26 oz/ft (117 g/m)	2.56 oz/ft (238 g/m)	2.46 oz/ft (229 g/m)
Static Bend Radius	1.0" (25.4 mm)	1.0" (25.4 mm)	1.375" (35mm)	1.375" (35mm)
Dynamic Bend Radius	1.75" (44.5mm)	2.0" (50.8mm)	2.5" (63.5mm)	2.5" (63.5mm)
ENVIRONMENTAL CHARACTERISTICS				
Operating Temperature Range ¹	-65°C to +200°C	-65°C to +200°C	-65°C to +200°C	-65°C to +200°C
RoHS 3 (EU 2015/863)	Yes	Yes	Yes	Yes

¹ Standard cable assembly temperature range is -55°C to +165°C, -65°C to +200°C available for select configurations

VSWR for assemblies with two straight connectors	1.35:1 to 18 GHz	1.35:1 to 18 GHz	1.35:1 to 18 GHz	1.35:1 to 18 GHz
VSWR for assemblies with one straight and one right angle connector	1.40:1 to 18 GHz	1.40:1 to 18 GHz	1.40:1 to 18 GHz	1.40:1 to 18 GHz
VSWR for assemblies with two right angle connectors	1.45:1 to 18 GHz	1.45:1 to 18 GHz	1.45:1 to 18 GHz	1.45:1 to 18 GHz

*Attenuation = $K1\sqrt{f} + K2f$ (cable only)



280 SERIES

OPERATING UP TO 18 GHz

CABLE ATTENUATION

ATTENUATION (MAX)

GHz	2801/2803			2806/2808		
	dB/ft.	dB/m	Power(W) @ 20°C @ Sea Level	dB/ft.	dB/m	Power(W) @ 20°C @ Sea Level
0.5	0.03	0.10	2550	0.04	0.13	2185
1	0.04	0.14	1900	0.06	0.18	1500
2	0.06	0.21	1350	0.08	0.26	1100
4	0.09	0.30	900	0.17	0.38	700
6	0.11	0.37	750	0.14	0.47	600
8	0.13	0.43	650	0.17	0.55	500
10	0.15	0.48	600	0.19	0.62	450
12	0.16	0.53	580	0.21	0.68	400
14	0.17	0.57	550	0.23	0.75	380
16	0.19	0.62	525	0.24	0.80	350
18	0.20	0.66	450	0.26	0.86	340

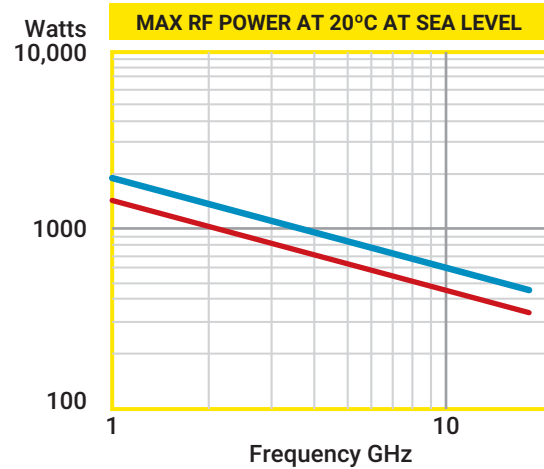
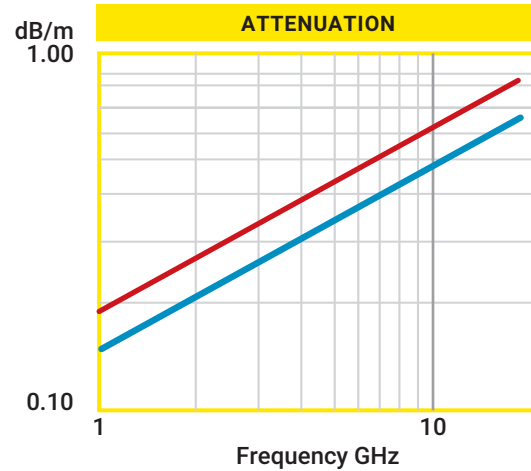
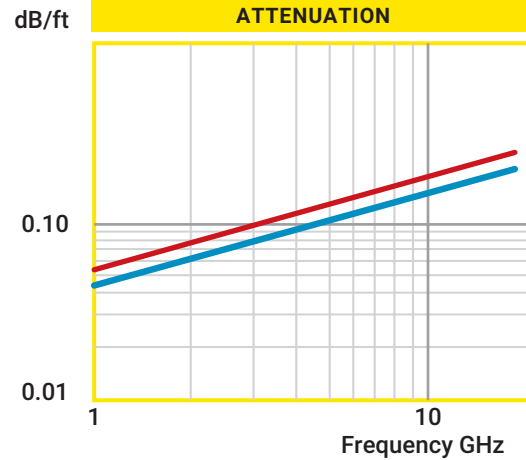



CONNECTORS FOR 280 SERIES

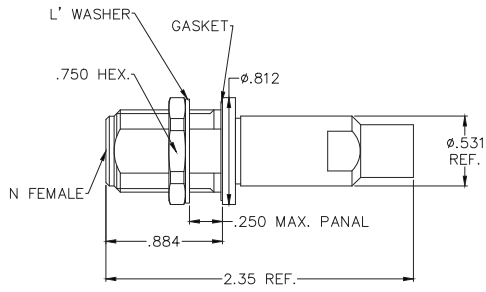

N-TYPE FEMALE BULKHEAD (NJB-2801)

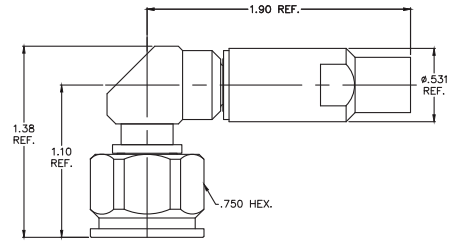

N-TYPE MALE RIGHT ANGLE (NPR-2801)

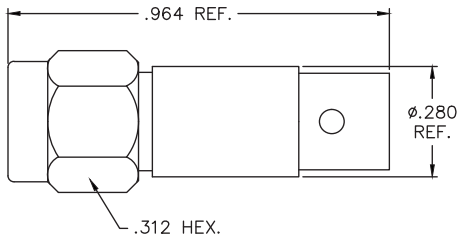

SMA MALE DIRECT SOLDER (SPSD-2801)

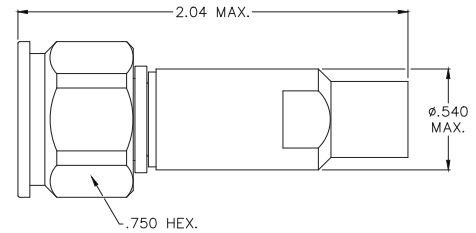

N-TYPE MALE (NPS-2801)

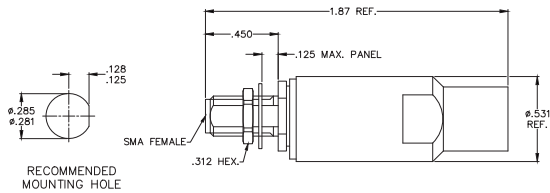

SMA FEMALE BULKHEAD (SJB-2801)

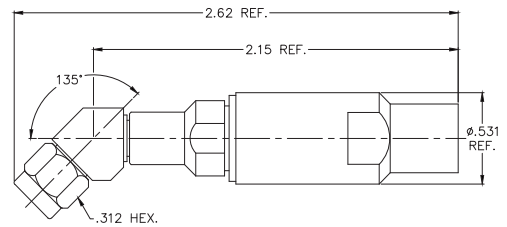

SMA MALE 45DEGREE (SPO-2801)

Other connector types and styles are available, please contact the factory



CONNECTORS FOR 280 SERIES

280 SERIES

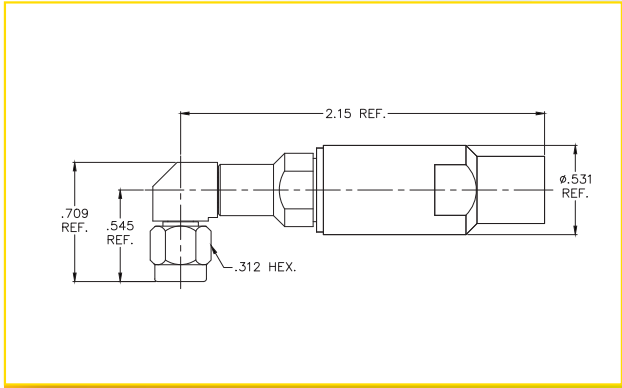

SMA MALE RIGHT ANGLE (SPRC-2801)

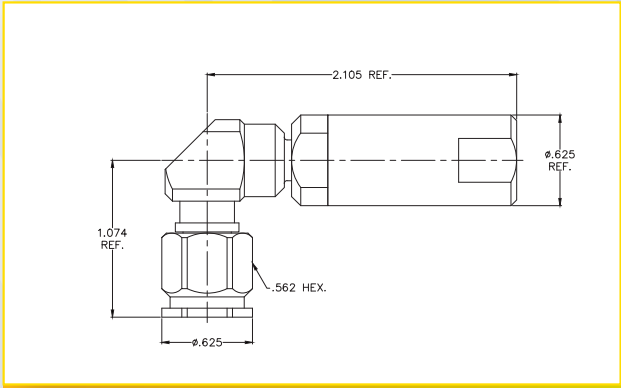

TNC MALE RIGHT ANGLE (TPR-2801)

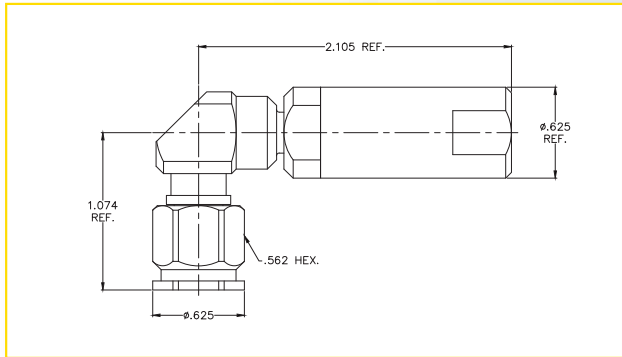

TNC MALE RIGHT ANGLE FOR EXTERNAL ARMOR (TPR-2801A)

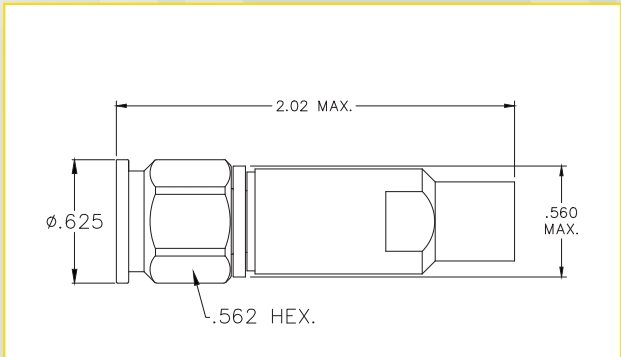

TNC MALE (TPS-2801)

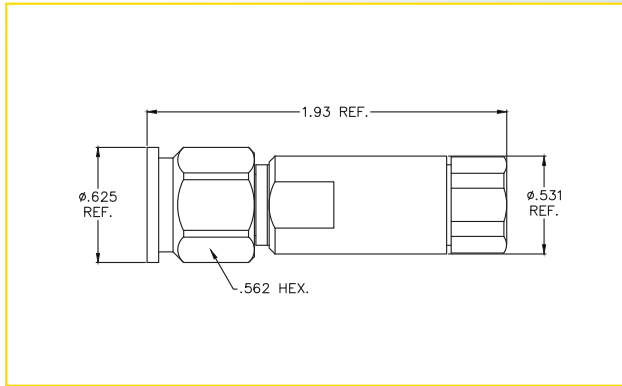

TNC MALE (TPS-2803)

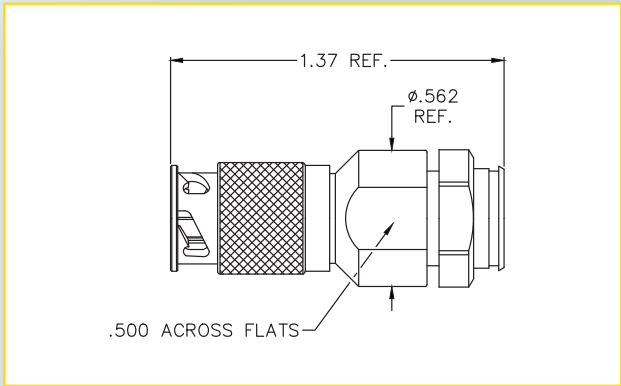

ZMA MALE (ZXPS-2801)

Other connector types and styles are available, please contact the factory



480 SERIES

OPERATING UP TO 11 GHz



Center Conductor
Silver Plated Copper

Dielectric
PTFE

Foil
Silver Plated
Copper

Braid
Silver Plated
Copper

Outer Jacket
FEP
(0.475", 12mm)

CABLE SPECIFICATIONS

	4806
ELECTRICAL CHARACTERISTICS	
Impedance	50 +/- 2Ω
Cut Off Frequency (cable only, max)	11.3 GHz
Capacitance	24.5pF/ft.
Velocity of Propagation	83%
Time Delay	1.22 ns/ft.
Shielding Effectiveness up to 18GHz	>90 dB
Cable Attenuation Factors *	K1 = 2.9, K2 = 0.179
Power Handling	See Chart
MECHANICAL CHARACTERISTICS	
Weight	2.93 oz/ft (272 g/m)
Static Bend Radius	3.0" (76mm)
Dynamic Bend Radius	5.0" (127mm)
ENVIRONMENTAL CHARACTERISTICS	
Operating Temperature Range	-65°C to +150°C
RoHS 3 (EU 2015/863)	Yes

¹ Standard cable assembly temperature range is -55°C to +165°C, -65°C to +200°C available for select configurations

VSWR for assemblies with two straight connectors

1.35:1 to 11 GHz

*Attenuation = $K1\sqrt{f} + K2f$ (cable only)



480 SERIES

OPERATING UP TO 11 GHz

CABLE ATTENUATION

ATTENUATION (MAX)

4806

GHz	dB/ft.	dB/m	Power(W) @ 20°C @ Sea Level
0.1	0.01	0.03	11000
0.5	0.02	0.07	4800
1	0.03	0.10	3250
2	0.04	0.15	2260
4	0.07	0.21	1650
6	0.08	0.27	1300
8	0.10	0.32	1100
10	0.11	0.36	950
11	0.12	0.38	900

dB/ft

ATTENUATION

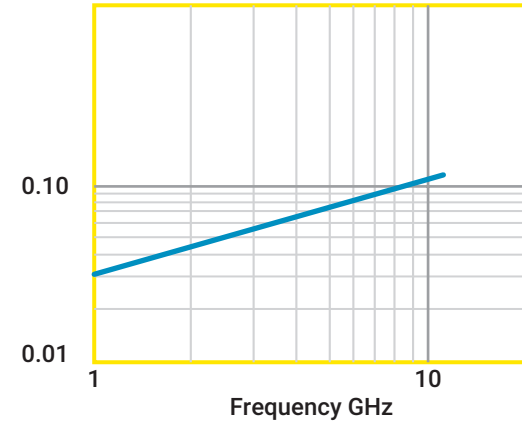

dB/m

ATTENUATION

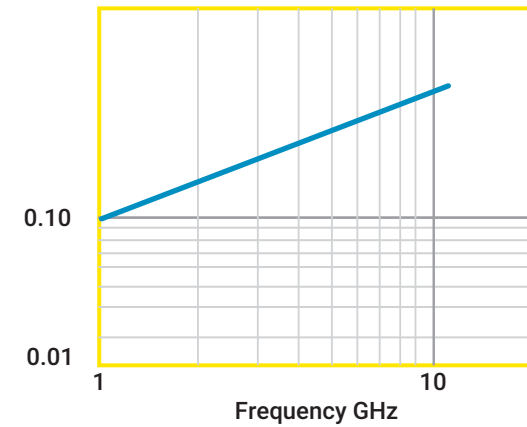

Watts

MAX RF POWER AT 20°C AT SEA LEVEL

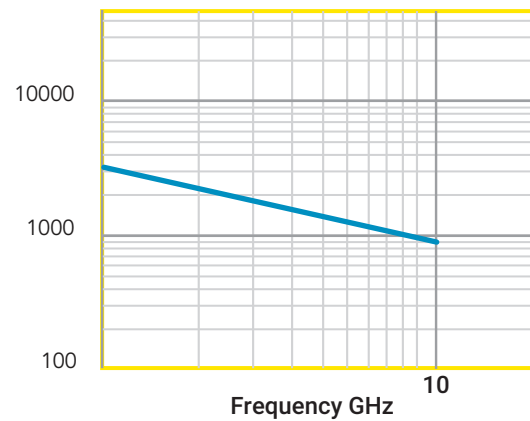

480 SERIES



CONNECTORS FOR 480 SERIES

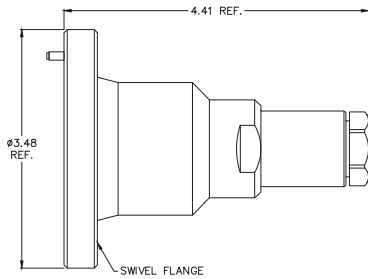

1 5/8 EIA FLANGE (158EF-4806)

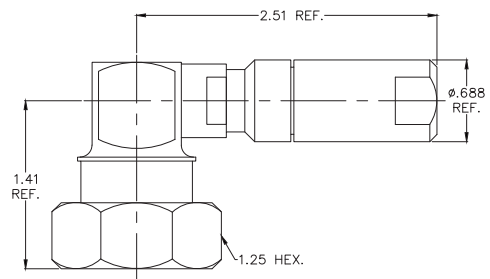

7/16 DIN MALE RIGHT ANGLE (716PR-4806)

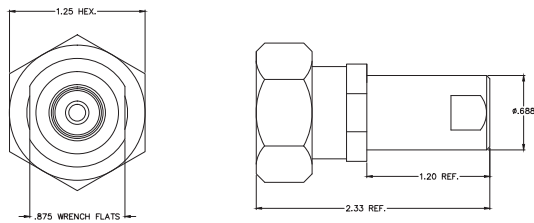

7/16 DIN MALE (CN269)

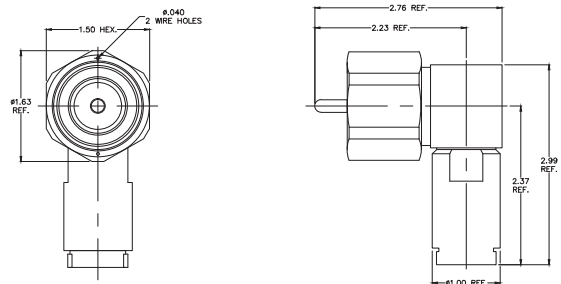

LC MALE RIGHT ANGLE W/LOCK WIRE HOLES (LCPRW-4806)

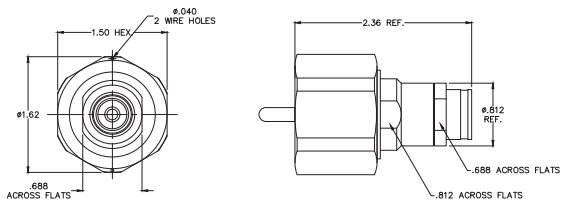

LC MALE W/LOCK WIRE HOLES (LPSW-4806)

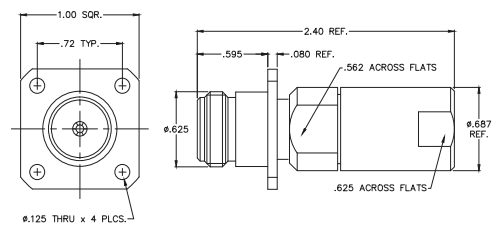

N-TYPE FEMALE FOUR HOLE FLANGE MOUNT NJP4-4806

Other connector types and styles are available, please contact the factory



CONNECTORS FOR 480 SERIES

480 SERIES

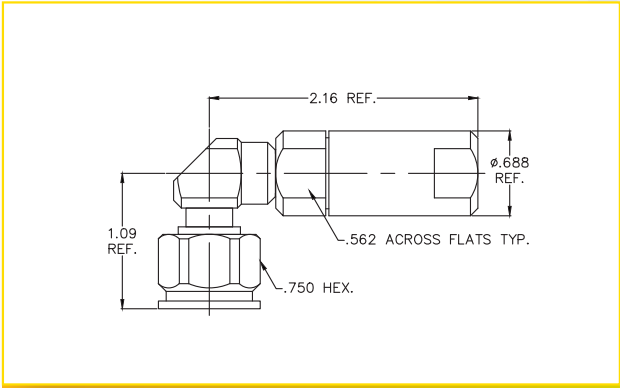

N-TYPE MALE RIGHT ANGLE (NPR-4806)

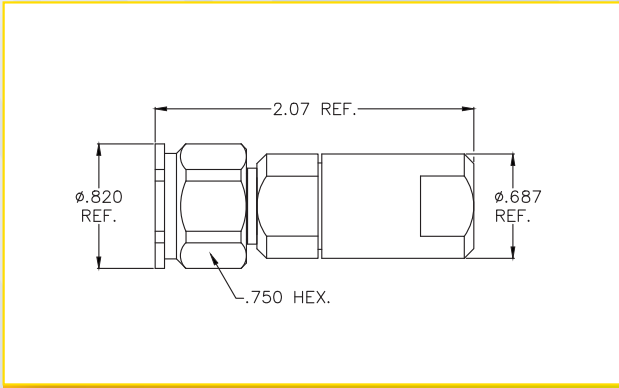

N-TYPE MALE (NPS-4806)

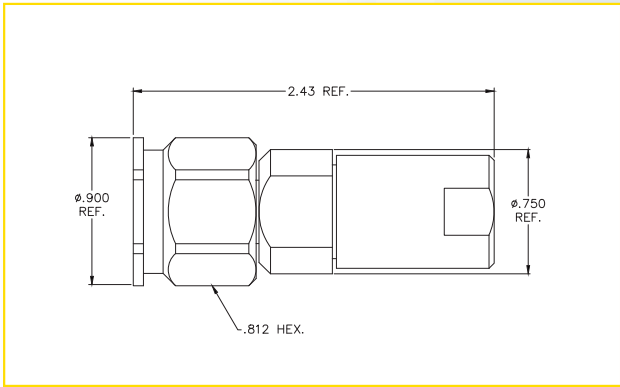

SC MALE (SCPS-4806)

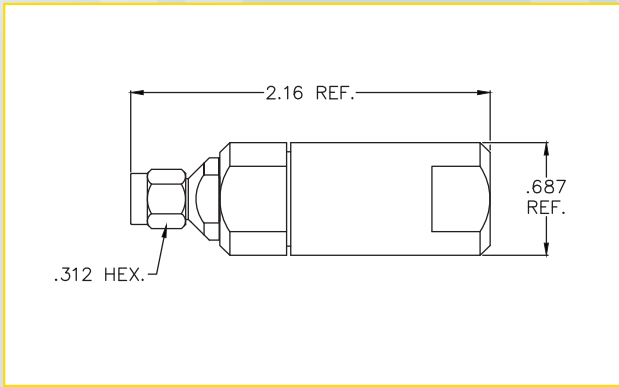

SMA MALE (SPS-4806)

Other connector types and styles are available, please contact the factory



750 SERIES

OPERATING UP TO 6.5 GHz

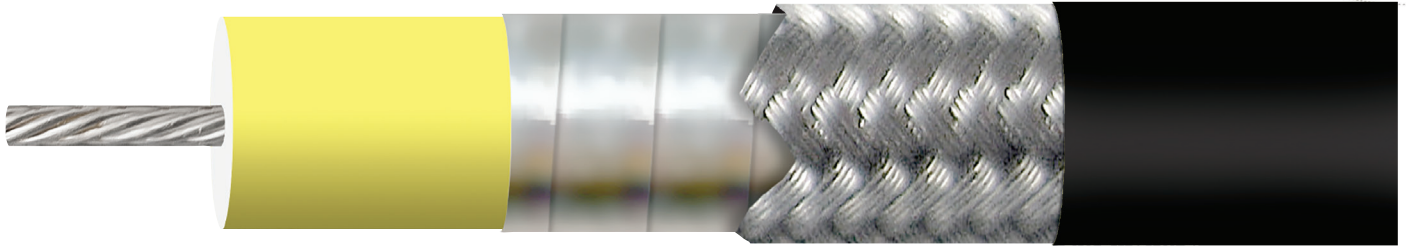

Center Conductor
Silver Plated
Copper Stranded

Dielectric
PTFE

Foil
Silver Plated
Copper

Braid
Silver Plated
Copper

Outer Jacket
Santoprene
(0.765", 19.68 mm)

CABLE SPECIFICATIONS

	7506-SP
ELECTRICAL CHARACTERISTICS	
Impedance	50 +/- 2Ω
Cut Off Frequency (cable only, max)	6.5 GHz
Capacitance	24.5 pF/ft.
Velocity of Propagation	83%
Time Delay	1.22 ns/ft.
Shielding Effectiveness up to 18GHz	>90 dB
Cable Attenuation Factors *	K1 = 1.9, K2 = 0.183
Power Handling	See Chart
MECHANICAL CHARACTERISTICS	
Weight	5.8 oz/ft (536 g/m)
Static Bend Radius	5" (127mm)
Dynamic Bend Radius	8.0" (203mm)
ENVIRONMENTAL CHARACTERISTICS	
Operating Temperature Range	-65°C to +135°C
RoHS 3 (EU 2015/863)	Yes

*Attenuation = $K1\sqrt{f} + K2f$ (cable only)



750 SERIES

OPERATING UP TO 11 GHz

CABLE ATTENUATION

ATTENUATION (MAX)

7506-SP

GHz	dB/ft.	dB/m	Power(W) @ 20°C @ Sea Level
0.1	0.006	0.020	20000
0.5	0.014	0.047	12500
1	0.021	0.069	10000
2	0.031	0.102	6690
3	0.038	0.125	5000
4	0.045	0.148	4475
5	0.051	0.167	3000
6	0.057	0.187	2500
6.5	0.060	0.198	1750

dB/ft
0.100

ATTENUATION

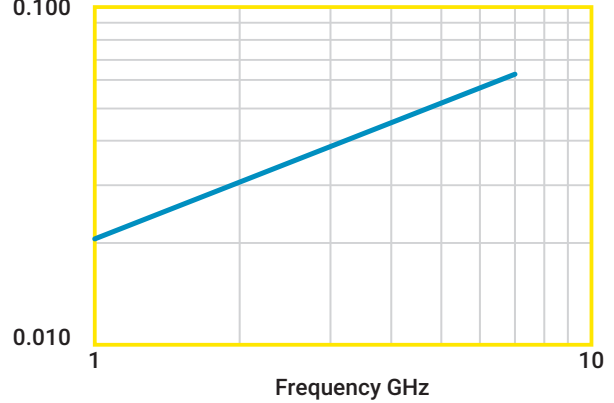

dB/m

ATTENUATION

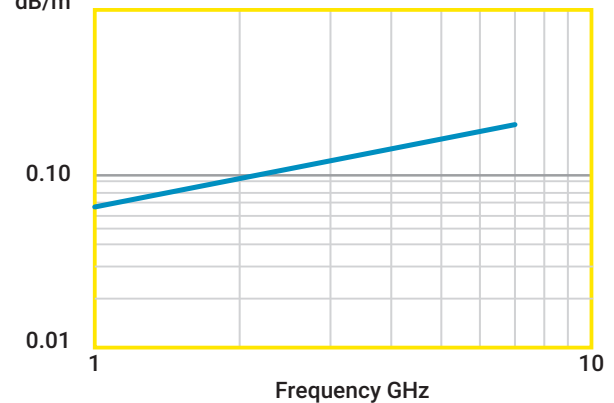

Watts
1000

ATTENUATION

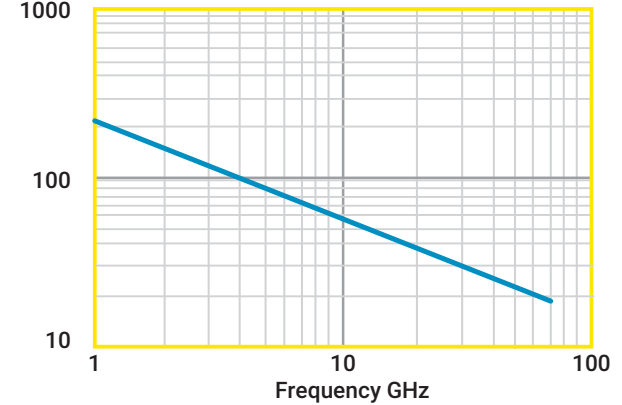

CONNECTORS FOR 150 SERIES

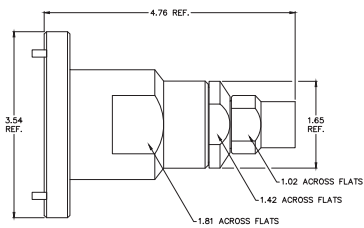

1 5/8 EIA FLANGE (158EF-7506)

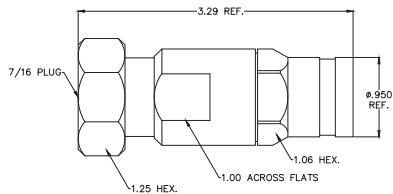

7/16 DIN MALE (716PS-7506)



75 Ω PRODUCTS

Insulated Wire now offers three line sizes of 75Ω cables utilizing the same technology and materials that give our 50Ω products industry leading performance.

All three cables employ expanded PTFE™ dielectric materials with silver plated copper conductors and

shielding to ensure lowest attenuation with maximum signal integrity from -55°C to +165°C.

Optional protection for Outside Broadcast applications include Low Smoke/Zero Halogen polyurethane jacketing to provide weather-proofing, and armoring options to prevent damage due to accidental damage.

1151-75:

Small diameter cable providing lower loss than RG179 with an 0.085" line size. BNC and HD BNC connectors are available, performing up to 18 GHz.

1601-75:

Mid-size cable providing loss comparable to RG59 with superior shielding performance in an 0.141" line size and performing up to 18 GHz.

1801-75:

Mid-size cable offering exceptional attenuation with Precision N and BNC connectors for applications where commodity cables cannot provide the performance required by increasing signal speeds; 1801-75 has been tested to 18 GHz.

2801-75:

Introduced to out-perform RG11 both electrically and mechanically. IW 280 series cable is a more flexible solution, intended to provide optimum attenuation performance to 18 GHz.



75 Ω SERIES

OPERATING UP TO 18 GHz

CABLE ATTENUATION

75 Ω SERIES

ATTENUATION (MAX)

1151-75

GHz	dB/ft.	dB/m	Power(W) @ 20°C @ Sea Level
0.5	0.14	0.45	175
1	0.2	0.64	124
2	0.28	0.93	88
4	0.41	1.34	62
6	0.51	1.67	51
8	0.6	1.96	44
10	0.68	2.22	39
12	0.75	2.46	36
14	0.82	2.68	33
16	0.88	2.9	31
18	0.95	3.1	29

ATTENUATION (MAX)

1601-75

GHz	dB/ft.	dB/m	Power(W) @ 20°C @ Sea Level
0.5	0.83	0.27	295
1	1.20	0.39	234
2	1.75	0.57	162.5
4	2.57	0.84	117
6	3.24	1.06	94.5
8	3.82	1.25	82.0
10	4.36	1.43	73.5
12	4.86	1.60	65.5
14	5.34	1.75	61.5
16	5.79	1.90	58.5
18	6.23	2.04	56.5

ATTENUATION (MAX)

1801-75

GHz	dB/ft.	dB/m	Power(W) @ 20°C @ Sea Level
0.5	0.05	0.17	415
1	0.08	0.25	344
2	0.11	0.36	237
4	0.16	0.51	172
6	0.19	0.63	138
8	0.22	0.74	120
10	0.25	0.83	108
12	0.28	0.91	95
14	0.3	0.99	90
16	0.33	1.07	86
18	0.35	1.14	84

ATTENUATION (MAX)

2801-75

GHz	dB/ft.	dB/m	Power(W) @ 20°C @ Sea Level
0.5	0.03	0.1	1032
1	0.04	0.14	817
2	0.06	0.2	581
4	0.09	0.29	387
6	0.11	0.37	323
8	0.13	0.43	280
10	0.15	0.49	258
12	0.16	0.54	249
14	0.18	0.59	237
16	0.19	0.63	226
18	0.21	0.68	194

VSWR PERFORMANCE AS 1.35:1 MAX

- 1151-75
- 1601-75
- 1801-75
- 2801-75

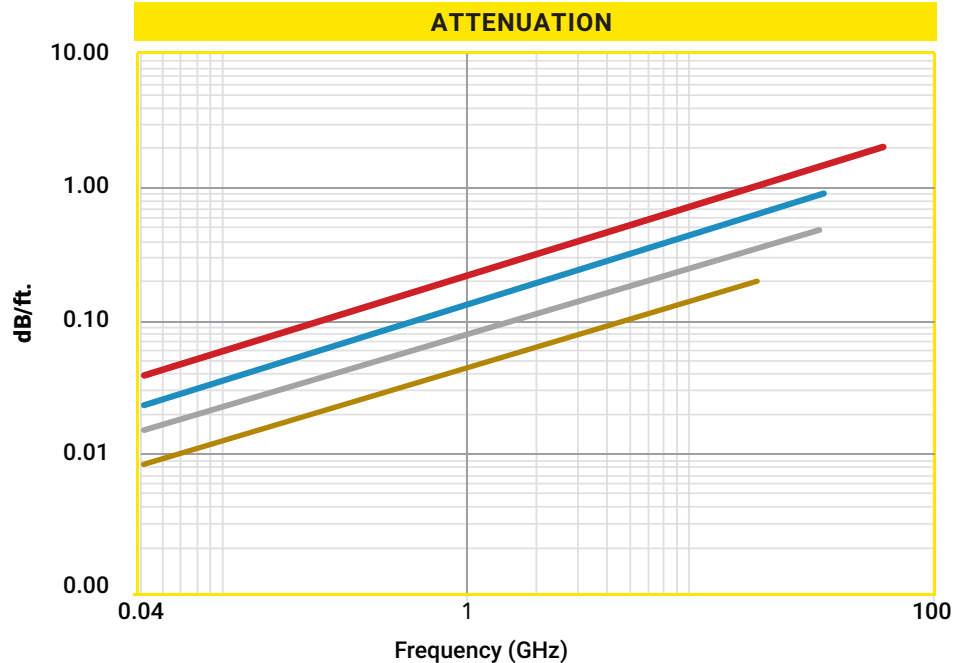



RE-FLEX™ PRODUCTS

To provide improved electrical and mechanical performance over traditional hand-formable designs, Insulated Wire presents Re-Flex™.

Available in 0.085", 0.141", 0.235" and 0.325" diameters (identified as RF085, RF141, RF250 and RF325), IW's RF cable series offers the advantages of the same lamination process used on our Low Loss products. Combined with the same double shield construction plus a solder-free tin/alloy plated outer braid, the Re-Flex™ design provides a re-formable cable that will not develop micro fractures with repeated flexing, eliminating manufacturability issues associated with conformable style RG cables.

Both RF085 and RF141 are industry standard line sizes, consequently a wide range of connector types and styles can be used with these cables, including: SMA, TNC, N, SMP, SMPM, 2.92mm/K™, 2.4mm and 1.85mm/V™, with performance up to 60GHz. RF250 is commonly used for higher power applications with SMA, TNC, N, SC and HN connectors available.

Re-Flex™ assemblies can be employed wherever a semi-rigid or conformable cable type is currently used, and with FEP™ jacket available as a standard option, Re-Flex™ provides greater versatility. Cable part numbers are TPRFEP085, TPRFEP141 and TPRFEP250.

RE-FLEX™ CABLE - KEY PERFORMANCE PARAMETERS

Cable Type	Maximum Frequency (cable only)	Attenuation (dB/ft., max)				Bend Radius (inch)	Replaces
		10 GHz	18 GHz	32 GHz	60 GHz		
RF085	62 GHz	0.60	0.91	1.28	2.01	0.25	RG405
RF141	34 GHz	0.41	0.60	0.88	-	0.375	RG402
RF250	19.5 GHz	0.29	0.44	-	-	0.375	-
RF325	11 GHz	0.21	-	-	-	0.625	-

RE-FLEX™ CABLE - AVAILABILITY

Cable Type	AMS-DTL-23053 Jacket Available	FEP Jacket Available	Distribution Stock
RF085	Yes	Yes	SMA (m) to SMA (m) direct solder, 3" and up
RF141	Yes	Yes	SMA (m) to SMA (m) direct solder, 3" and up SMA (m) to SMA (m) shell style, 2" and up
RF250	Yes	Yes	



RE-FLEX™ STARTER KITS

RE-FORMABLE CABLE ASSEMBLY SOLUTIONS
STRAIGHT OUT OF THE BOX!



RE-FLEX

For customers who know the advantages of Re-Flex over traditional hand-formable and semi-rigid, and to make cable selection easier for those new to our product, IW is pleased to announce our new range of Re-Flex Starter Kits!

Three kits are currently available:

CT-1879 (SPSD-TPRF085-XXX-SPSD) direct solder SMA male/male using TPRF085 (RG405 line size)

CT-1880 (SPSD-TPRF141-XXX-SPSD) direct solder SMA male/male using TPRF141 (RG402 line size)

CT-1881 (SPSH-TPRF141-XXX-SPSH) shell style SMA male/male using TPRF141 (RG402 line size)

Each kit comprises seven different assembly lengths 3", 4", 5", 6", 8", 9" and 12", 5 pcs of each, providing the design engineer with a convenient aid for performing cable routing in prototype system builds

The ability to **continually re-form Re-Flex** without the need for custom tooling to shape the cable, and the elimination of debris caused by micro fracturing is a key feature of the **Re-Flex** cable design, and enables the designer to make signal path/layout changes without having to throw product away after using it once.



RF085

OPERATING UP TO 62 GHz



Center Conductor
Silver Plated
Copper

Dielectric
PTFE

Foil
Silver Plated
Copper

Braid
Tin Plated Copper
RF085 - (0.085", 2.15 mm)

CABLE SPECIFICATIONS

	RF085
ELECTRICAL CHARACTERISTICS	
Impedance	50 +/- 2Ω
Cut Off Frequency (cable only, max)	61 GHz
Capacitance	28.6 pF/ft.
Velocity of Propagation	71%
Time Delay	1.43 ns/ft.
Shielding Effectiveness up to 18GHz	>90 dB
Cable Attenuation Factors (K1, K2) *	18.8, 0.86
Power Handling	See Chart
MECHANICAL CHARACTERISTICS	
Weight	0.19 oz/ft (17.86 g/m)
Static Bend Radius	0.25" (6.35 mm)
Dynamic Bend Radius	0.375" (95.25mm)

FEP Jacket available upon request

*Attenuation = $K1\sqrt{f} + K2f$ (cable only)



RF085

OPERATING UP TO 62 GHz

CABLE ATTENUATION

ATTENUATION (MAX)						
RF085						
GHz	dB/ft.	dB/m	Power(W) @ 20°C @ Sea Level	dB/ft.	dB/m	Power(W) @ 20°C @ Sea Level
0.5	0.14	0.46	357	0.17	0.55	310
1	0.20	0.67	220	0.24	0.78	196
2	0.29	0.96	200	0.34	1.12	170
4	0.42	1.39	120	0.49	1.62	107
A	0.53	1.73	85	0.62	2.02	76
8	0.62	2.03	75	0.72	2.36	67
10	0.70	2.30	70	0.81	2.67	63
12	0.78	2.56	65	0.90	2.96	58
14	0.85	2.79	60	0.98	3.22	54
16	0.92	3.01	55	1.06	3.48	49
18	0.98	3.23	50	1.13	3.72	45
20	1.04	3.42	45	1.19	3.89	40
22	1.10	3.62	43	1.26	4.13	38
24	1.17	3.82	42	1.33	4.36	38
26	1.23	4.02	40	1.40	4.58	36
28	1.28	4.21	39	1.46	4.80	35
30	1.34	4.40	38	1.53	5.01	34
32	1.40	4.58	37	1.59	5.22	33
34	1.45	4.76	36	1.65	5.43	32
36	1.51	4.94	35	1.72	5.63	31
38	1.56	5.11	32	1.78	5.83	29
40	1.61	5.28	30	1.84	6.02	27
42	1.66	5.45	29	1.90	6.22	26
44	1.71	5.62	28	1.95	6.41	25
46	1.76	5.79	27	2.01	6.60	24
48	1.81	5.95	26	2.07	6.78	23
50	1.86	6.11	25	2.12	6.97	22
52	1.91	6.27	25	2.18	7.15	22
54	1.96	6.43	25	2.24	7.33	22
56	2.01	6.59	23	2.29	7.51	21
58	2.06	6.74	23	2.34	7.69	21
60	2.10	6.90	22	2.40	7.86	20
62	2.15	7.05	22	2.45	8.04	20

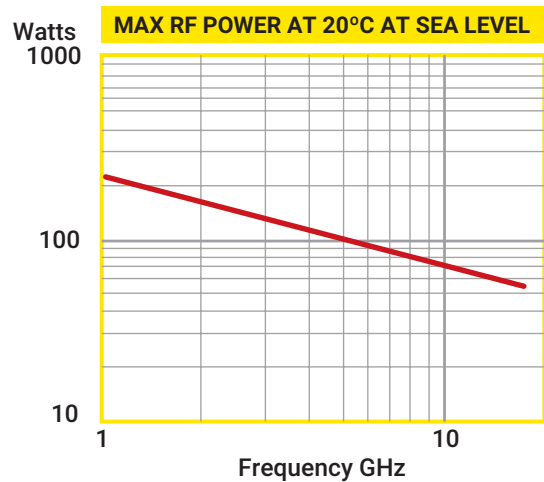
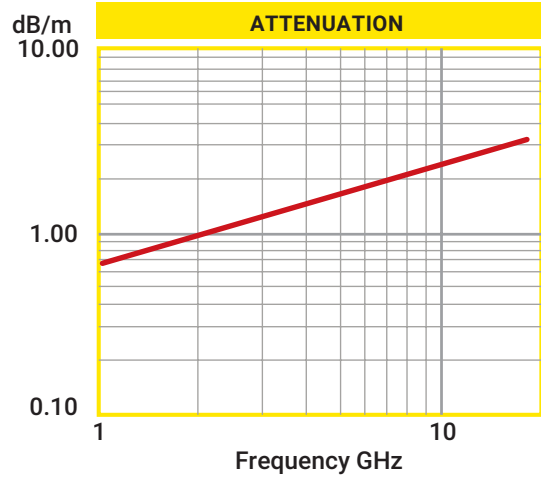
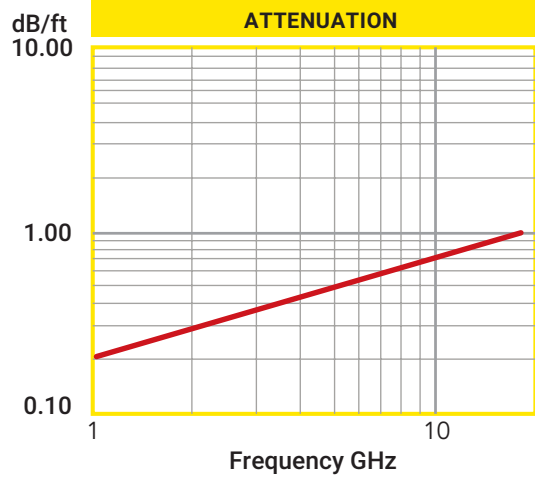



CONNECTORS FOR RF085

RF 085 SERIES

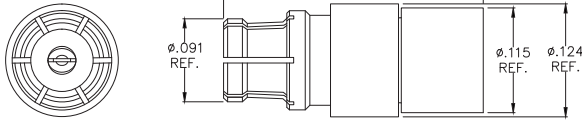

GPO JACK/FEMALE (GGJS-TPRF085)

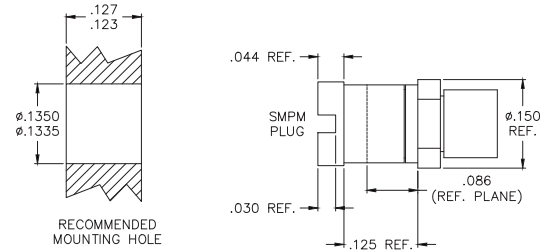

GPO MALE BULKHEAD (GGPB-TPRF085)

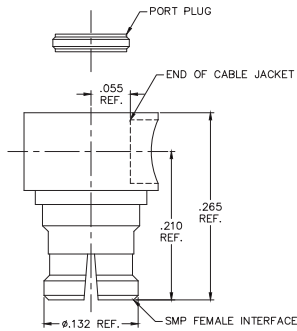

GPO FEMALE RIGHT ANGLE (GJR-TPRF085)

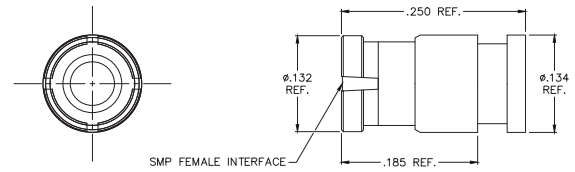

GPO JACK/FEMALE (GJS-TPRF085)

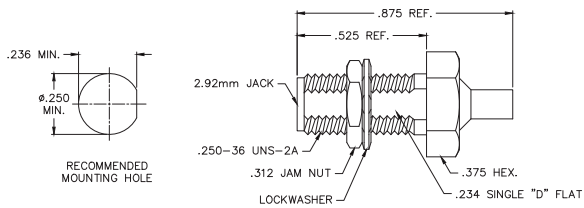

2.92MM FEMALE BULKHEAD (KJB-TPRF085)

Other connector types and styles are available, please contact the factory



CONNECTORS FOR RF085

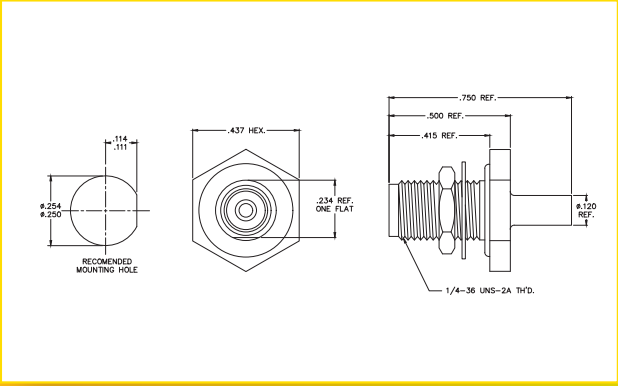

SMA FEMALE BULKHEAD (SJBD-TPRF085)

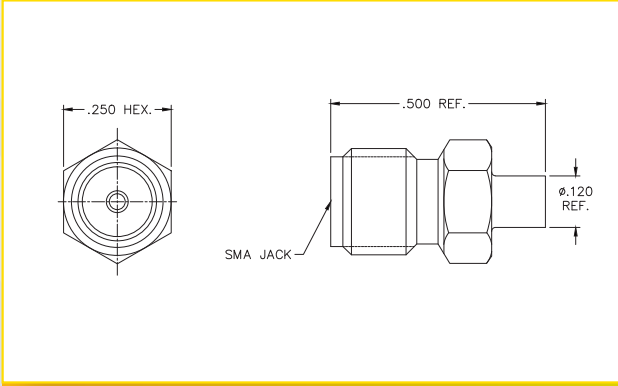

SMA FEMALE (SJSD-TPRF085)

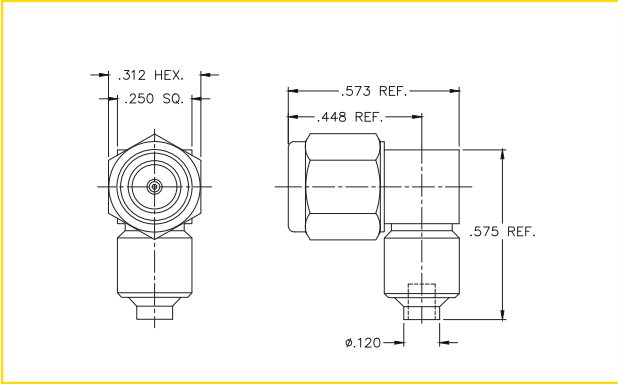

SMA MALE RIGHT ANGLE (SPRCD-TPRF085)

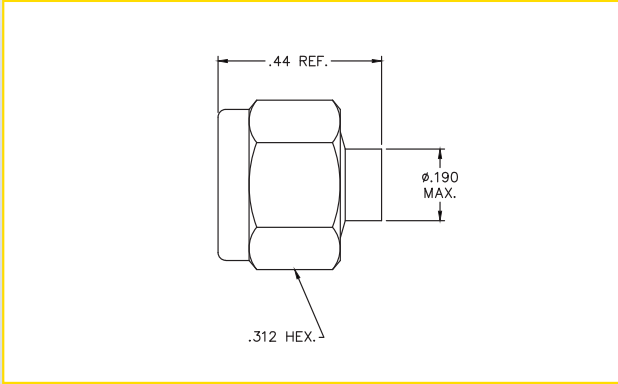

SMA MALE (SPSD-TPRF085)

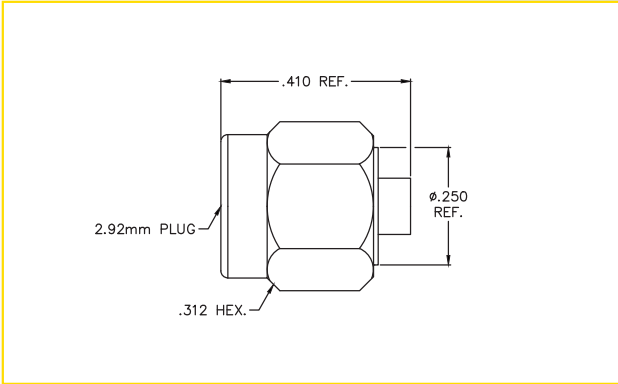

2.92MM MALE (KPSD-TPRF085)

RF 085 SERIES

Other connector types and styles are available, please contact the factory



RF141

OPERATING UP TO 33 GHz



Center Conductor
Silver Plated
Copper

Dielectric
PTFE

Foil
Silver Plated
Copper

Braid
Tin Plated Copper
RF141 - (0.141", 3.58 mm)

CABLE SPECIFICATIONS

	RF141
ELECTRICAL CHARACTERISTICS	
Impedance	50 +/- 2Ω
Cut Off Frequency (cable only, max)	33 GHz
Capacitance	28.6 pF/ft.
Velocity of Propagation	71%
Time Delay	1.43 ns/ft.
Shielding Effectiveness up to 18GHz	>90 dB
Cable Attenuation Factors (K1, K2) *	10.6, 0.86
Power Handling	See Chart
MECHANICAL CHARACTERISTICS	
Weight	0.19 oz/ft (17.86 g/m)
Static Bend Radius	0.375" (9.53 mm)
Dynamic Bend Radius	0.75" (19.05 mm)

FEP Jacket available upon request

*Attenuation = $K_1\sqrt{f} + K_2f$ (cable only)



RF141

OPERATING UP TO 33 GHz

CABLE ATTENUATION

ATTENUATION (MAX)			
RF141			
GHz	dB/ft.	dB/m	Power(W) @ 20°C @ Sea Level
0.5	0.078	0.226	635
1	0.11	0.38	430
2	0.17	0.55	291
4	0.25	0.81	197
6	0.31	1.02	157
8	0.37	1.21	133
10	0.42	1.38	118
12	0.47	1.54	106
14	0.52	1.70	97
16	0.56	1.84	90
18	0.60	1.98	84

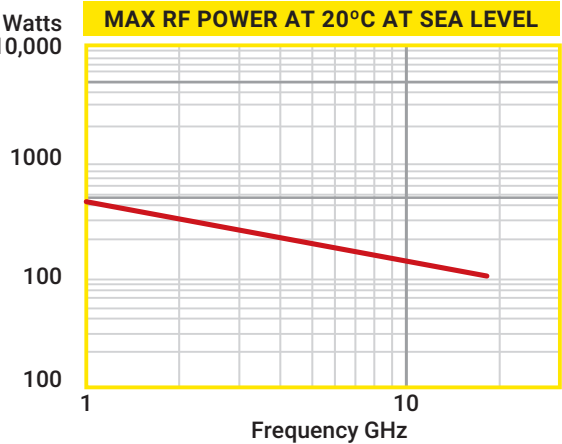
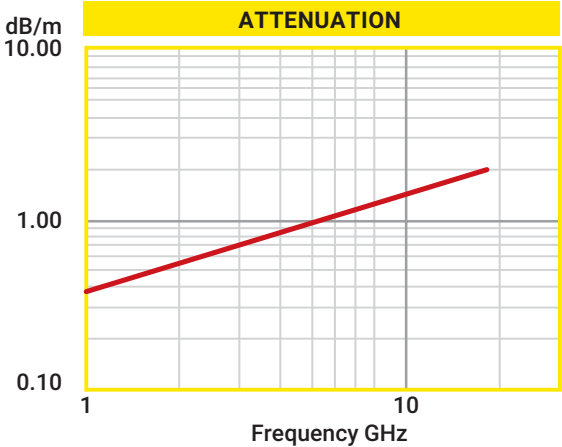
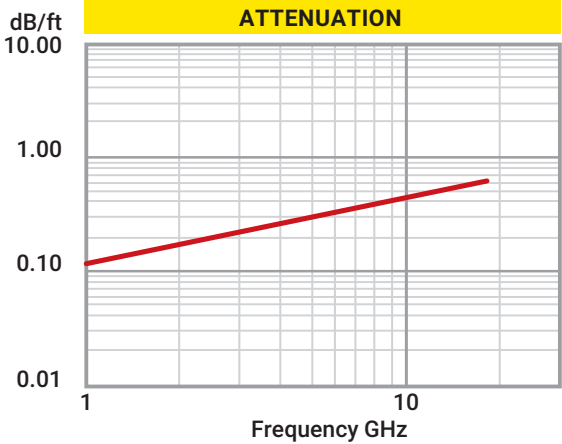



CONNECTORS FOR RF141

RF 141 SERIES

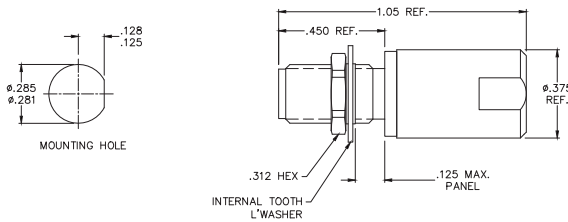

SMA FEMALE BULKHEAD (SJB-TPRF141)

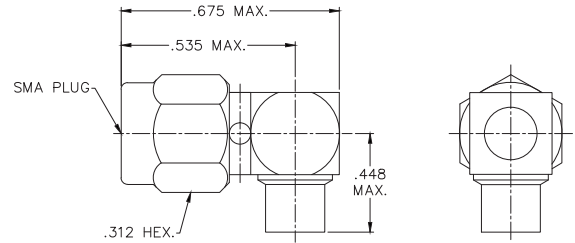

SMA MALE RIGHT ANGLE DIRECT SOLDER (SPRCD-TPRF141)

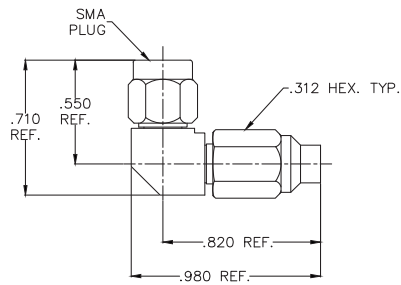

SMA MALE RIGHT ANGLE (SPRC-TPRF141)

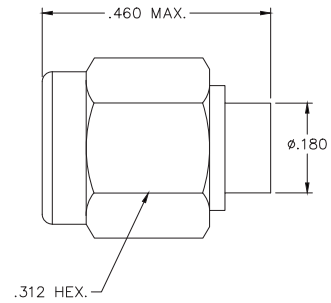

SMA MALE DIRECT SOLDER (SPSD-TPRF141)

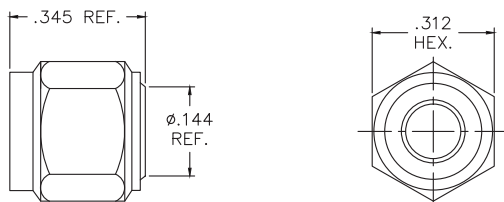

SMA MALE SHELL (SPSH-TPRF141)

Other connector types and styles are available, please contact the factory



CONNECTORS FOR RF141

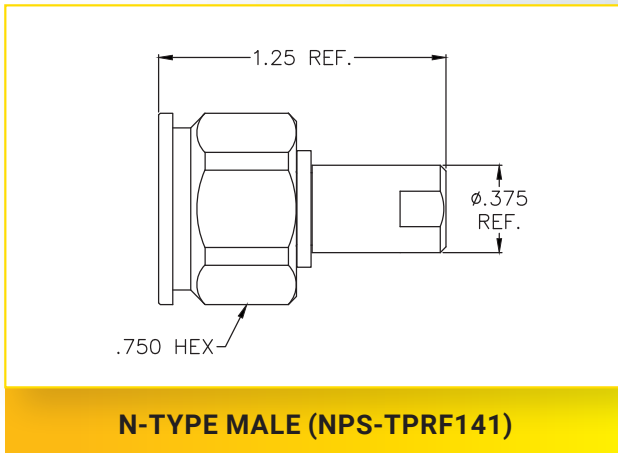
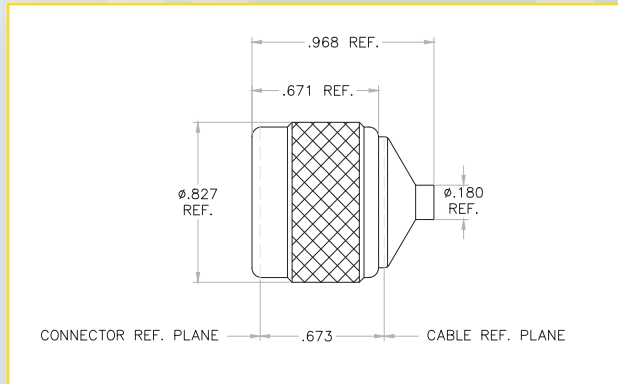
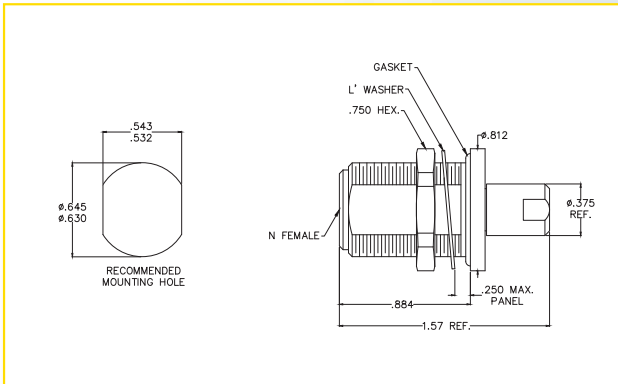
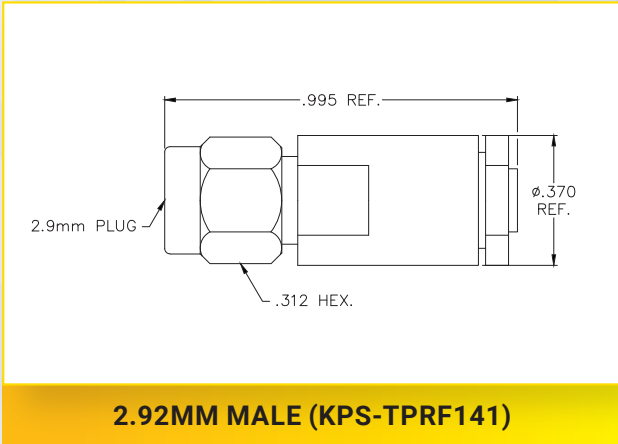
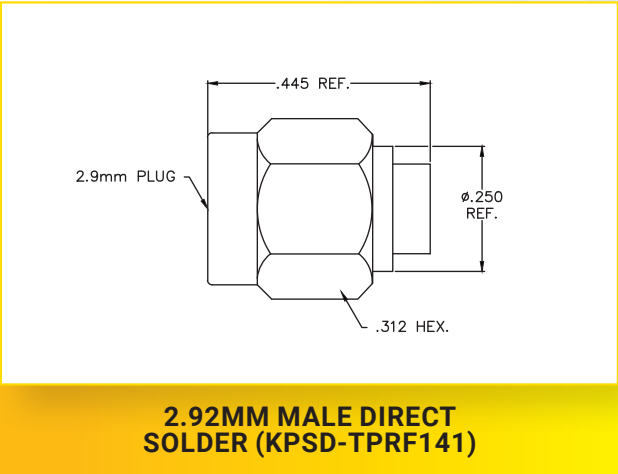

RF 141 SERIES



RF250

OPERATING UP TO 18 GHz



Center Conductor
Silver Plated
Copper

Dielectric
PTFE

Foil
Silver Plated
Copper

Braid
Tin Plated Copper
RF250 - (0.230", 5.84 mm)

CABLE SPECIFICATIONS

	RF250
ELECTRICAL CHARACTERISTICS	
Impedance	50 +/- 2Ω
Cut Off Frequency (cable only, max)	18 GHz
Capacitance	28.6 pF/ft.
Velocity of Propagation	71%
Time Delay	1.43 ns/ft.
Shielding Effectiveness up to 18GHz	>90 dB
Cable Attenuation Factors (K1, K2) *	6.4, 0.95
Power Handling	See Chart
MECHANICAL CHARACTERISTICS	
Weight	1.06 oz/ft (98.2 g/m)
Static Bend Radius	0.375" (95.25mm)
Dynamic Bend Radius	1.0" (25.4mm)

FEP Jacket available upon request

*Attenuation = $K1\sqrt{f} + K2f$ (cable only)



RF250

OPERATING UP TO 18 GHz

CABLE ATTENUATION

ATTENUATION (MAX)

RF250

GHz	dB/ft.	dB/m	Power(W) @ 20°C @ Sea Level
0.5	0.05	0.16	1615
1	0.07	0.23	1033
2	0.11	0.36	661
4	0.17	0.56	423
6	0.22	0.72	326
8	0.26	0.85	271
10	0.29	0.95	235
12	0.34	1.12	209
14	0.37	1.21	189
16	0.41	1.35	173
18	0.44	1.44	161

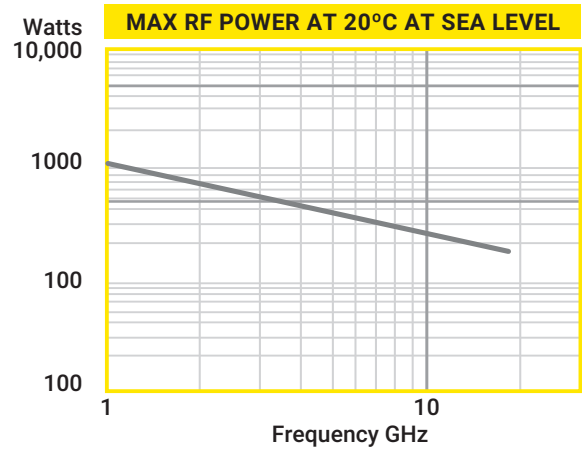
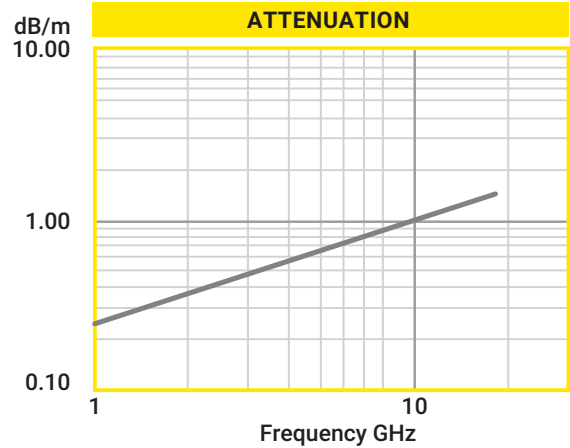
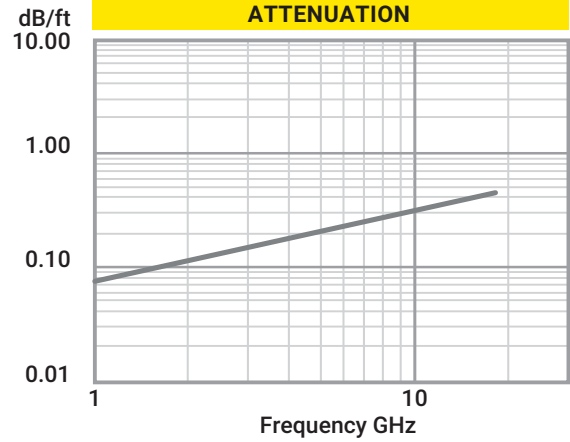



CONNECTORS FOR RF250

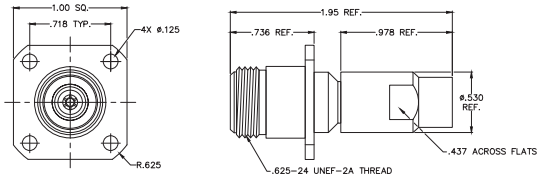

**N-TYPE FEMALE 4 HOLE
FLANGE MOUNT (NJP4-TPRF250)**

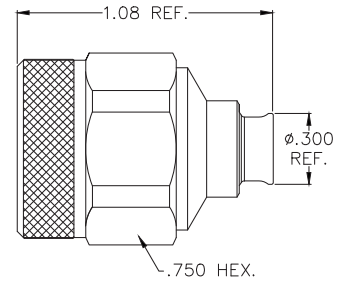

NPSDTPRF250-SPEC_A_GEN

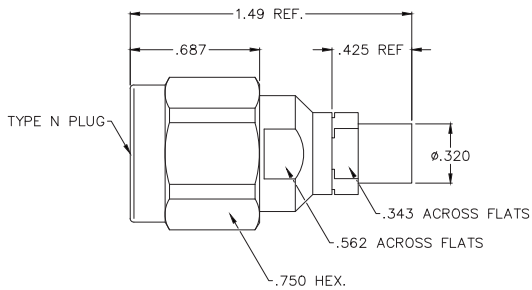

N-TYPE MALE (NPS-TPRF250)

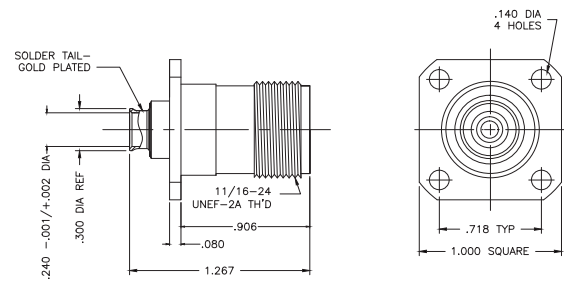

**SC FEMALE DIRECT SOLDER 4 HOLE
FLANGE MOUNT SCJP4-TPRF250**

Other connector types and styles are available, please contact the factory



CONNECTORS FOR RF250

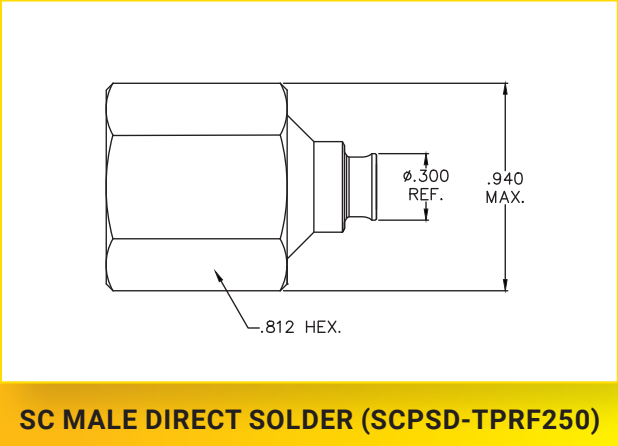

SC MALE DIRECT SOLDER (SCPSD-TPRF250)

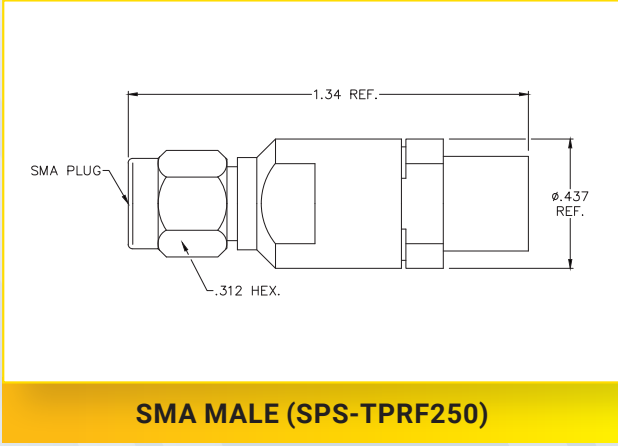

SMA MALE (SPS-TPRF250)

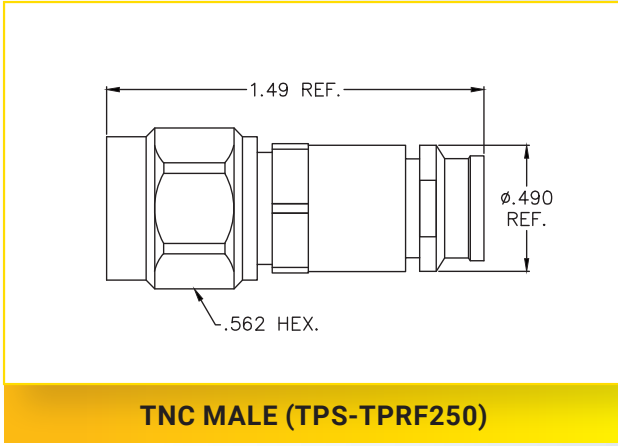

TNC MALE (TPS-TPRF250)



SEMI RIGID SERIES



Center Conductor
Silver Plated
Copper/Steel Solid

Dielectric
PTFE

Outer Jacket
Copper
50S047 - (0.047", 1.19 mm)
50S085 - (0.088", 2.23 mm)
50S141 - (0.141", 3.58 mm)
50S250 - (0.250", 6.35 mm)

CABLE SPECIFICATIONS

	50S047	50S085	50S141	50S250
ELECTRICAL CHARACTERISTICS				
Impedance	50 +/- 2Ω	50 +/- 2Ω	50 +/- 2Ω	50 +/- 2Ω
Cut Off Frequency (cable only, max)	110 GHz	62 GHz	35 GHz	18 GHz
Capacitance	29 pF/ft.	28.6 pF/ft.	28.6 pF/ft.	28.6 pF/ft.
Velocity of Propagation	70%	71%	71%	71%
Time Delay	1.45 ns/ft.	1.43 ns/ft.	1.43 ns/ft.	1.43 ns/ft.
Shielding Effectiveness up to 18GHz	>90 dB	>90 dB	>90 dB	>90 dB
Cable Attenuation Factors (K1, K2) *	33.2, 0.83	18.7, 0.82	10.5, 0.85	6.0, 0.81
Power Handling	See Chart	See Chart	See Chart	See Chart
MECHANICAL CHARACTERISTICS				
Weight	0.06 oz/ft (5.60 g/m)	0.26 oz/ft (24.5 g/m)	0.52 oz/ft (48.37 g/m)	1.76 oz/ft (163.7 g/m)
Minimum Bend Radius	0.0625" (1.59mm)	0.125" (3.18 mm)	0.25" (6.35 mm)	0.375" (9.52mm)
ENVIRONMENTAL CHARACTERISTICS				
Operating Temperature Range ¹				-65°C to +125°C
RoHS 3 (EU 2015/863)				Yes

Semi-Rigid supplied in cut lengths or coils.

Available as bare copper or plated with tin, tin-lead, or silver.

*Attenuation = $K1\sqrt{f} + K2f$ (cable only)



SEMI RIGID SERIES

CABLE ATTENUATION

ATTENUATION (MAX)

50S047

GHz	dB/ft.	dB/m	Power(W)@ 20°C @ Sea Level
0.5	0.24	0.78	82
1	0.34	1.11	58
5	0.78	2.57	25
10	1.13	3.71	19
18	1.56	5.10	14

ATTENUATION (MAX)

50S085

GHz	dB/ft.	dB/m	Power(W)@ 20°C @ Sea Level
0.5	0.14	0.45	232
1	0.20	0.64	162
5	0.46	1.51	70
10	0.67	2.21	48
18	0.94	3.09	35

ATTENUATION (MAX)

50S141

GHz	dB/ft.	dB/m	Power(W)@ 20°C @ Sea Level
0.5	0.08	0.26	600
1	0.11	0.37	450
5	0.28	0.91	180
10	0.42	1.36	120
18	0.60	1.96	83

ATTENUATION (MAX)

50S250

GHz	dB/ft.	dB/m	Power(W)@ 20°C @ Sea Level
0.5	0.05	0.15	1950
1	0.07	0.22	1500
5	0.17	0.57	765
10	0.27	0.89	350
18	0.40	1.31	210

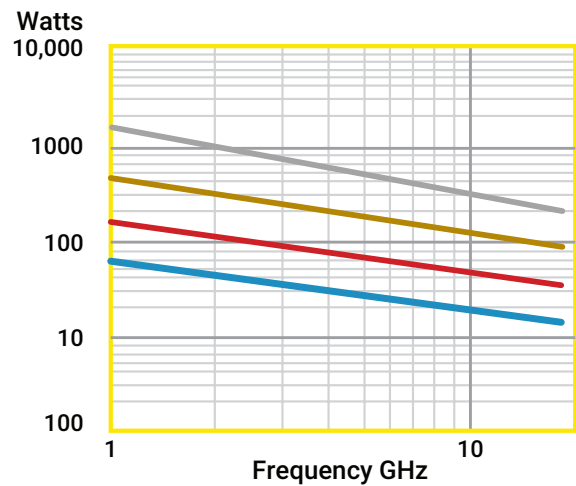
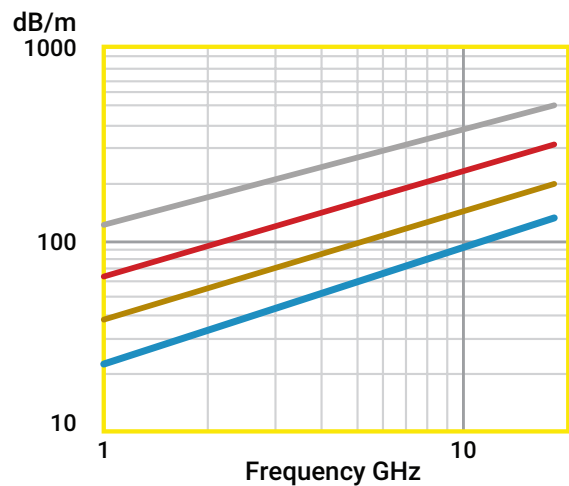
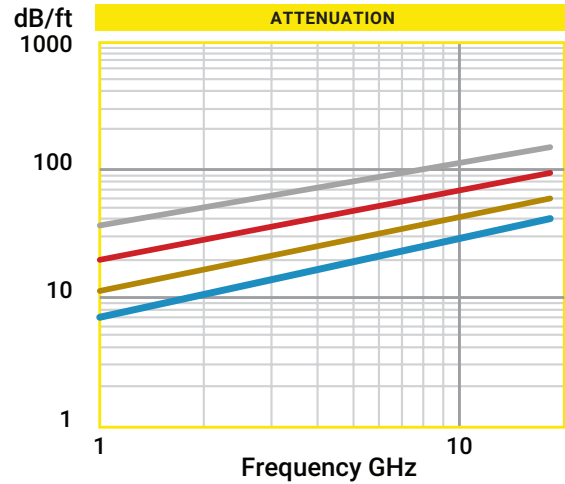

CONNECTOR OPTIONS



This catalog lists the most common configurations for each cable type. If necessary, IW can modify existing designs or design a custom connector to meet your specific requirements.

Our standard connectors meet the environmental specifications of MIL-PRF-39012. Our N, TNCA and SMA connectors are optimized to be 18 GHz, all others meet applicable industry standards.

MATERIALS & FINISHES

Component	Material Specifications	Finish Specifications
Bodies	Stainless Steel per AMS-5640 UNS-S30300, Type 1	Passivation per SAE-AMS-2700
Coupling Nut	Stainless Steel per AMS-5640 UNS-S30300, Type 1	Passivation per SAE-AMS-2700
Contacts	Beryllium Copper per ASTM-B-196 Brass per ASTM-B-16	Gold Plated per ASTM-B-488 Gold Plated per ASTM-B-488
Solder Ferrule	Brass per ASTM-B-16	Gold Plated per ASTM-B-488
Dielectric	PTFE (polytetrafluoroethylene) per ASTM-D-1710 Kel-F ASTM-D-1430-03 ULTEM* (Grade 1000) <i>*Trademark General Electric Corporation</i>	
Gasket	Silicone Rubber per A-A-59588 Viton ASTM-D-1418	

CONNECTOR OPTIONS

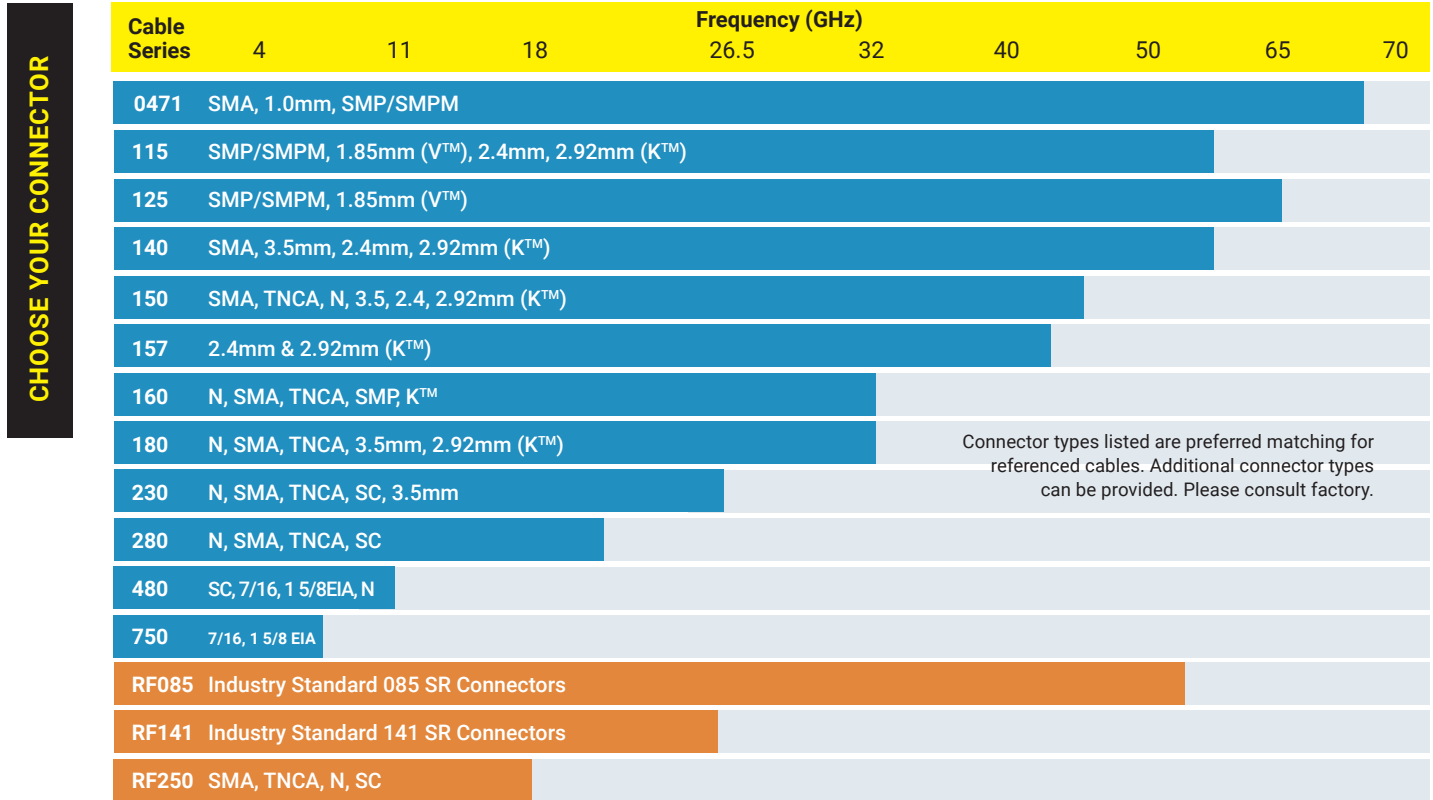

Calculation of Cable Assembly Loss Standard

$$dB = \left(\frac{\text{Cable Attenuation in dB/ft}}{12} \times L(\text{in.}) \right) + \text{Connector Loss}$$

Where L is Length in Inches

Calculation of Cable Assembly Loss Metric

$$dB = \left(\text{dB/m} \times L(\text{m}) \right) + \text{Connector Loss}$$

CONNECTOR INSERTION LOSS (PER CONNECTOR) (F IN GHZ)

Cable Series	Connector Type	Maximum Cable Frequency (GHz)	Straight (dB)	Right Angle (dB)
0471	SMA, 2.92mm (K™), 2.4mm, 1.85mm (V™), SMP/SMPM	110	.012 x F	.017 x F
115	SMP/SMPM, 1.85mm (V™), 2.4mm, 2.92mm (K™)	60	.012 x F	.017 x F
125	SMP/SMPM, 1.85mm (V™)	70	.005 x F	N/A
140	2.4 mm, 2.92mm (K™)	50	.01 x F	N/A
150	SMA, TNCA, N, 3.5, 2.4, 2.92mm (K™)	45	.01 x F	N/A
157	2.4mm & 2.92mm (K™)	40	.01 x F	N/A
160	N, SMA, TNCA, SMP, K™	22	.012 x F	.017 x F
180	N, SMA, TNCA 3.5 mm/2.92mm (K™)	18 26.5	.012 x F .01 x F	.017 x F N/A
230	N, SMA, TNCA, SC 3.5 mm	18 26.5	.012 x F .01 x F	.017 x F N/A
280	N, SMA, TNCA, SC	22	.012 x F	.017 x F
480	N, 7/16, SC & C, 15/8 EIA	11	.012 x F	.017 x F
750	7/16, 1 5/8 EIA, 3 1/8 EIA	7.5	.012 x F	
RF085	Industry Standard 085 SR Connectors	60	.012 x F	.017 x F
RF141	Industry Standard 141 SR Connectors	26.5	.01 x F	N/A
RF250	SMA, TNCA, N, SC	18	.012 x F	.017 x F

CABLE ASSEMBLY PART NUMBER BUILDER

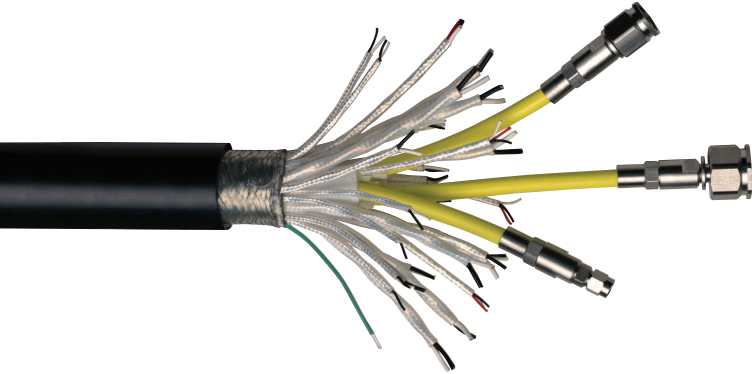

CONNECTOR CODES

- B** BNC
- G** GPO*/SMP
- GG** GPPO*/SMPM
- K** 2.92 mm (K™)
- MB** SMB
- MC** SMC
- N** N
- O** OSP*/BMA
- S** SMA
- SC** SC
- SS** SSMA
- T** TNCA
- V** 1.85 mm (V™)
- Z1** ZMA-90°
- Z2** ZMA-120°
- Z3** ZMA-130/130/100
- Z4** ZMA-110/110/140
- 7** 7 mm
- 3** 3.5 mm
- 2** 2.4 mm

TYPE CODES

- J** Jack
- P** Plug

STYLE CODES

- B** Bulkhead mount
- O** Obtuse angle (135°)
- P2** 2 hole panel mount
- P4** 4 hole panel mount
- R** Right angle
- RW** Right angle w/ wire holes
- RX** Extended right angle
- S** Straight
- SD** Straight direct solder
- SH** Shell type
- SW** Straight w/ wire holes
- RC** Right angle, cube body
- RCD** Right angle, cube body, direct solder
- SQ** Straight "Quik-Flex™"

OPTIONAL PROTECTION

- A** Stainless steel flexible armor
- N** Black neoprene jacket
- NX** Nomex
- LC** Low smoke / zero halogen polyurethane

† LC – LS/ZH jacket is available for 140-480 series cables, including 03/06/08; not recommended for Re Flex™. LC jacket can be combined with external armor code 'A' for maximum crush resistance in outdoor environments.

†† Neoprene, 'N' can be applied to all cable types.

Please consult the factory for custom/ application specific jacket requirements.

DIFFERENTIATOR CODES

- 1** Solid center conductor
- 3** Tuf-Flex™ solid center conductor
- 6** Stranded conductor
- 8** Tuf-Flex™ stranded center conductor

* OSP is a trademark of M/ACOM.

* GPO/GPPO is a trademark of Corning Gilbert

* K/V is a trademark of Anritsu

CABLE ASSEMBLY PART NUMBER BUILDER

With so many variables involved in creating custom wires for multiple purposes, IW has devised an Part Number (P/N) Coding System which we use to readily identify all our microwavcables.

In the first example part number below, the cable assembly is an SMA right angle plug to a 2301 armored cable at 36" long to an SMA straight plug.

STANDARD PART NUMBER

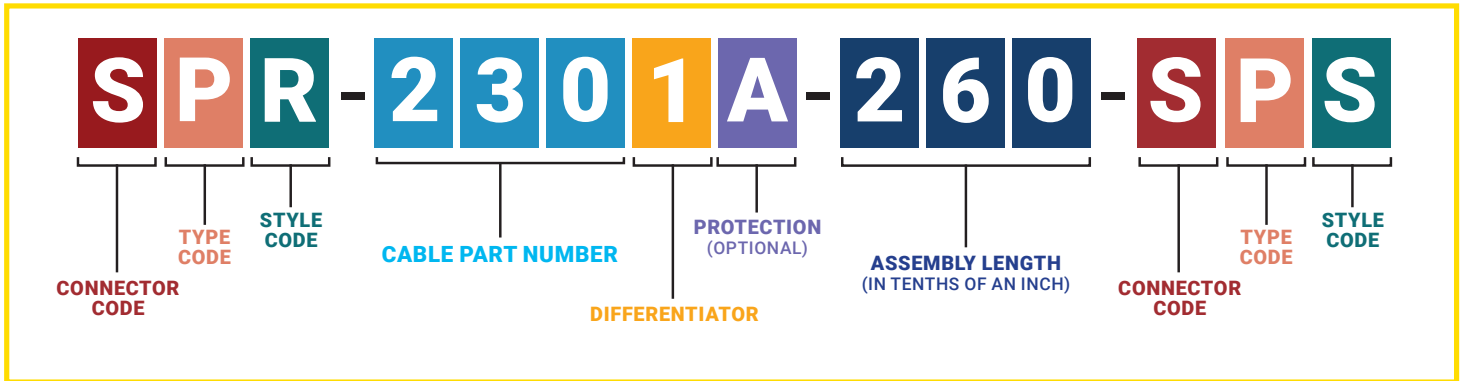

METRIC PART NUMBER

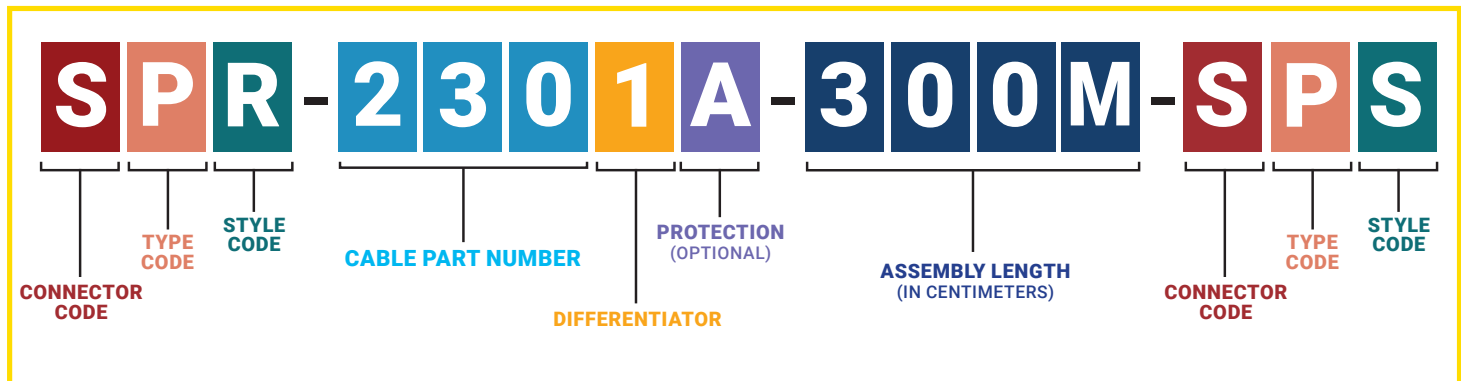

Note: Metric part number format is X.XX meters – 300M defines a 3m length assembly; a 10m assembly part number with the same connectors as shown above is SPR-2301A-1000M-SPS

ADAPTER PART NUMBER

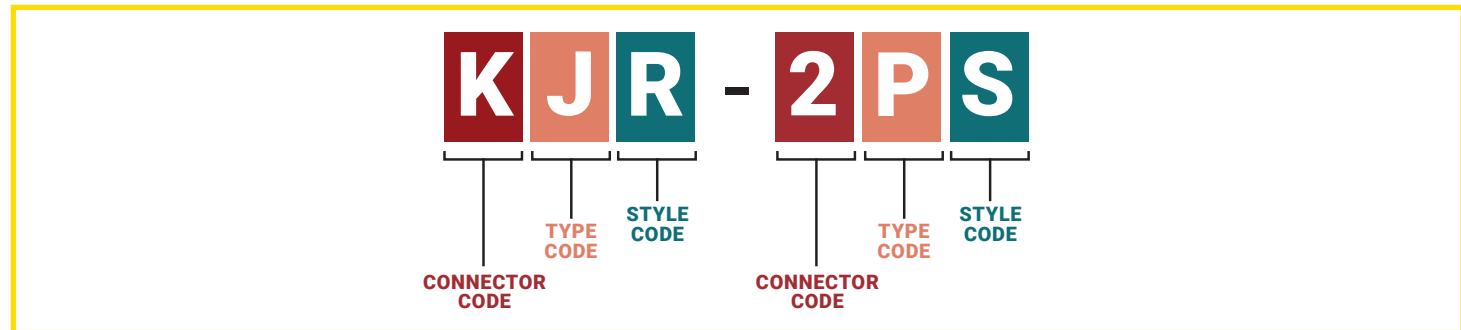

ASSEMBLY LENGTH DEFINITION

The outlines below show typical cable assembly configurations and reference points to determine overall length.

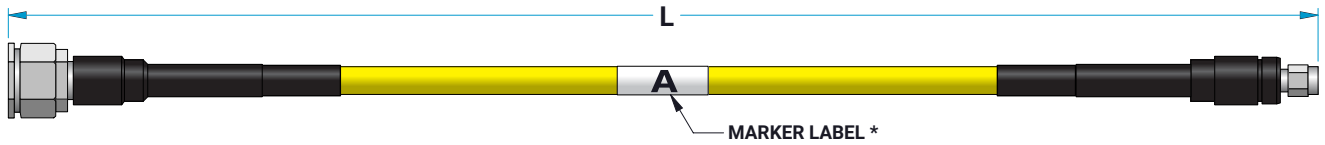

Fig. 1 – NPS-XXXX-XXX-SPS

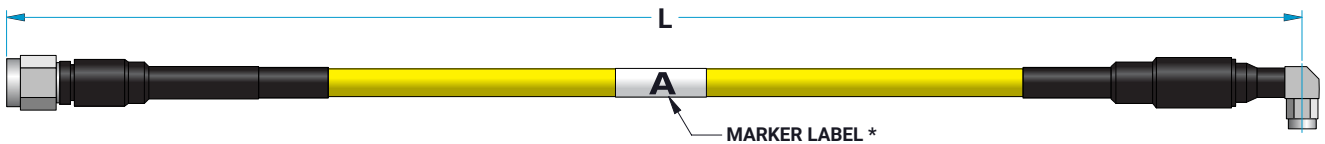

Fig. 2 – TPS-XXXX-XXX-SPRC

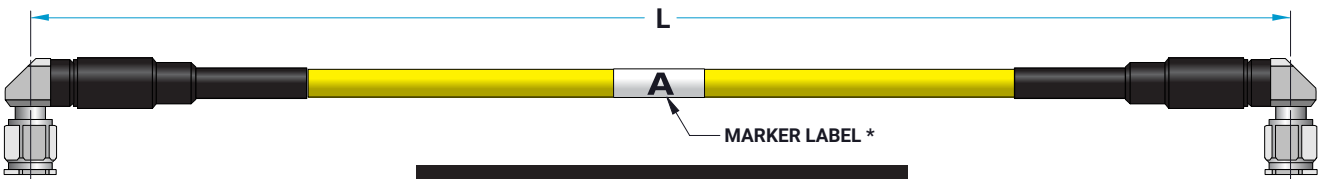

Fig. 3 – TPR-XXXX-XXX-TPR

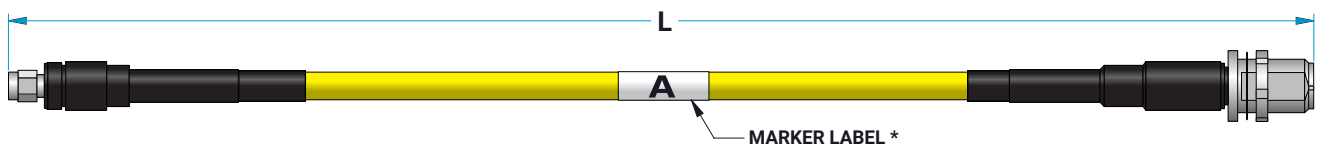

Fig. 4 – SPS-XXXX-XXX-NJB

* A center marker label is fitted to all assemblies over 6" in length; two markers located close to the cable ends are fitted for assemblies greater than 10ft./120"/3m.

Length (in.)	Tolerance (in.)	Length (cm)	Tol (cm)
6 to < 12	+0.50/-0.00	16 to < 30	+1.5/-0.00
12 to < 72	+1.00/-0.00	30 to < 180	+3/-0.00
72 < Length	+2.00/-0.00	180 < Length	+6/-0.00

Note: For Re-Flex™ assemblies with SMA direct solder or shell style connectors, the tolerances are...

2" to < 36"	±0.100"
36" to < 72"	±0.250"
72" < Length	±0.500"

COAXIAL ADAPTERS PART NUMBERS

	KJS	KPS	NJS	NPS	SCJS	SCJS	SJS	SPS	TBJ	TJP4	TJS	TPS	2JS	2PS	3JS	3PS	7S
KJR		X															
KJS	X	X											X	X	X	X	
KPR		X															
KPS	X	X											X	X	X		
NJB			X				X	X			X						
NJP4							X	X									
NJS			X	X	X	X	X	X			X	X					
NPR				X													
NPS			X	X	X	X	X	X			X	X					
SCJS			X	X													X
SCPS			X	X													X
SJS			X	X			X	X	X	X	X	X					X
SPS			X	X			X	X			X	X					X
TJB							X	X			X	X					
TJP4							X										
TJS			X	X			X	X	X			X					X
TPS			X	X			X	X	X		X	X					X
2JS	X	X											X	X	X	X	X
2PS	X	X											X	X		X	X
3JS	X	X											X		X	X	
3PS	X												X	X	X	X	

Additional styles available. Consult factory

OPTIONAL PROTECTION

BESPOKE PROTECTION

Microwave transmission lines are quite often exposed to a wide range of hostile environments. These may include extreme temperature, abrasion, compressive forces, high pressure fluids, solvents, chemicals, salt water, UV, vibration, and mechanical stress, just to name a few.

CUSTOM SOLUTIONS

In addition to our internally ruggedized cables, IW has a wide range of materials and processes designed to protect the integrity of our cable assemblies. These include a variety of metallic and non-metallic external sheaths to address your specific application. Please contact us for details.

**ZEL****Tefzel™ jacket**

Tefzel™ is a trademark of Chemours Company FC, LLC

NX**Fire resistant Nomex® braid**

Nomex® is a registered trademark of the DuPont Corporation

A**Interlocked stainless steel armor, crush resistant
up to 400 lbs per linear inch****N****Neoprene weather proof jacket****ALC****Armor w/extruded Polyurethane jacket**

TUF-FLEX™ CABLE PERFORMANCE

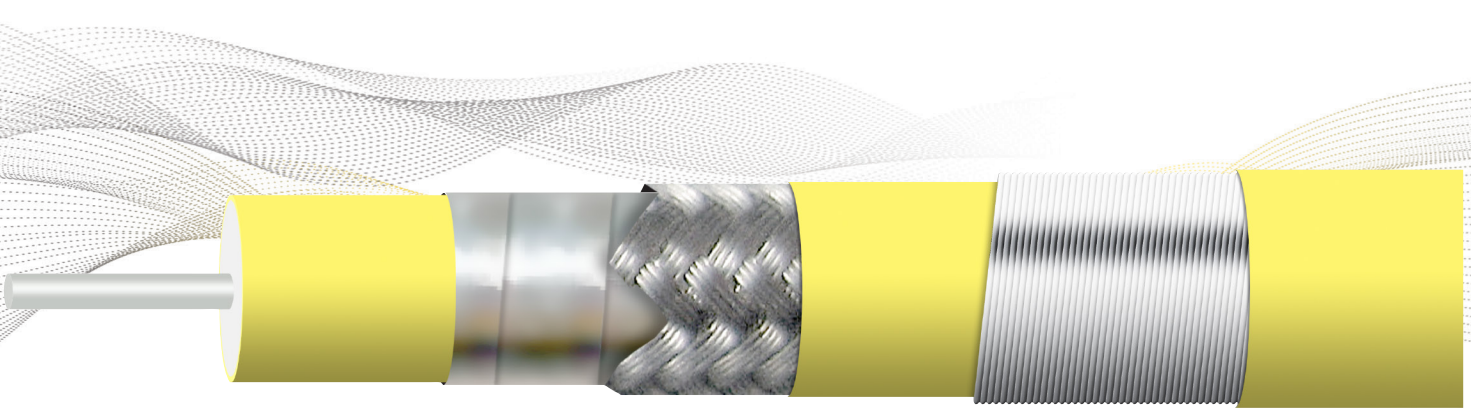

IW's range of Tuf-Flex™ cables was introduced to provide a high level of crush resistance for applications where an unarmored cable could be subject to damage, e.g. long assemblies used in a test chamber; down-mast, air frame, etc. where a cable needs to be secured in position and could be subject to high levels of vibration.

The following tables show the results of crush and bend tests performed on IW's Tuf-Flex™ internally ruggedized cable. The test samples were 2ft. overall length, using 1803 cable.

Results show maximum VSWR and Insertion Loss, tested across a frequency range of 40 MHz to 18 GHz. The test sample was placed between two 1" diameter plates with the force applied to the top plate.

**TUF-FLEX™ CABLE PERFORMANCE
CRUSH RESISTANCE**

1803 Cable		
Force (lbs.)	VSWR (max.)	Insertions Loss dB (max.)
0	1.32	1.1
80	1.32	1.1
160	1.32	1.1
200	1.32	1.1
250	1.35	1.1
300	1.43	1.2

The same cable was tested to measure performance with successively tighter bend radii.

**TUF-FLEX™ CABLE PERFORMANCE
BEND RADIUS**

1803 Cable		
Bend Radius (inches)	VSWR (max.)	Insertions Loss dB (max.)
Straight	1.25	1.1
1/4	1.25	1.1
1/8	1.32	1.1
Straight	1.25	1.1

The serving used to create the armor not only provides excellent crush resistance, but maintains the concentricity of the cable as it is flexed through a radius, enabling RF performance to be maintained.

PHASE MATCH AND TIME DELAY

For applications where phase or electrical length is a critical performance parameter, IW can provide matched assembly sets, tested to customer specifications, typically up to 40 GHz, with both Low Loss Phase Stable and Re-Flex™ cable types.

Relative phase matching is a common requirement achieved with multiple assembly sets. Typical phase matching tolerances are shown in Table 1 below.

FREQUENCY (GHz)	PHASE MATCH (DEGREES)
10	± 2
18	± 3.5
26.5	± 5
40	± 8

Tighter tolerances may be achievable; IW engineers review all matching requirements on a case by case basis. In addition, IW also provides time delay matched assemblies with tolerances in the order of 2pS being achievable with both Low Loss and Re-Flex™ cable types, and individual assemblies can also be supplied trimmed to a specific electrical length.

All matched assemblies are tested 100% for insertion loss and VSWR performance parameters in addition to phase.

PHASE CHARACTERISTICS

MAX PHASE CHANGE

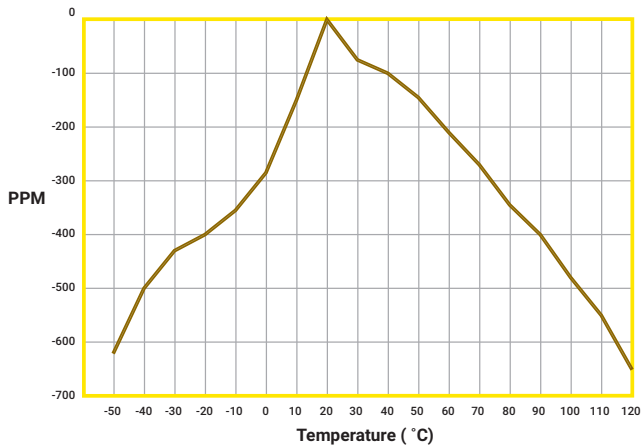

Max Phase Change for the following cable series:
 140, 150, 157, 170, 180, 230, 280 & 480

TYPICAL PHASE CHANGE

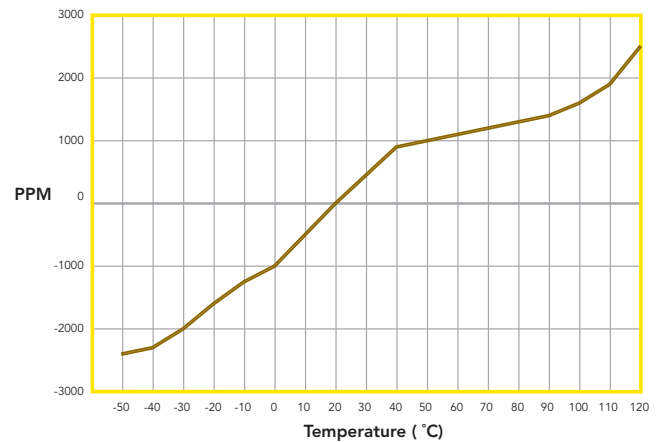

Typical phase Change for the following cable series
 047, 115, 125, 160, RF085, RF141 and RF250

DETERMINATION OF PHASE CHANGE OVER TEMPERATURE

The following example illustrates how to calculate the change in phase (and the tracking error) of cable assemblies over a specific temperature range. In this example, the cable is IW 2801, and the temperature range is -40°C to +80°C.

* determined by the charts above

** tracking error of two or more assemblies of the same type

PHASE CHANGE WITH FLEXING

Phase change when flexing will be slightly different depending on the particular cable. Larger cables have more dielectric and greater internal forces, thus phase change will be greater for cables with larger diameters. When wrapped 360° around a 4 inch diameter mandrel, the phase change will be:

$\pm 0.30^\circ \cdot f$ - for cables 480, 280, 230, 180 and 170

$\pm 0.20^\circ \cdot f$ - for cables 157, 150 and 140

1. CALCULATE ELECTRICAL LENGTH

2. CALCULATE CHANGE IN PHASE

3. CALCULATE TRACKING ERROR

Frequency = 10 GHz	f
Assembly length = 72 in	L
Start temp = 20°C	T
Dielectric const = 1.4	e
Change in PPM = -500*	PPM
PPM tracking error = ± 100 PPM tracking	
Electrical length = TBD	Φ
Change in phase = TBD	$\Delta\Phi$
Tracking error = TBD**	Φ tracking

$$\Phi = \frac{L \cdot \sqrt{e} \cdot f \cdot 360}{11.808}$$

$$\Phi = \frac{72 \cdot \sqrt{1.4} \cdot 10 \cdot 360}{11.808} = 25,973^\circ$$

$$\Delta\Phi = \frac{\Phi \cdot \text{PPM}}{1,000,000}$$

$$\Delta\Phi = \frac{25973 \cdot (-500)}{1,000,000} = -12.93^\circ$$

$$\Phi_{\text{tracking}} = \frac{\Phi \cdot (\text{PPM tracking})}{1,000,000}$$

$$\Phi_{\text{tracking}} = \frac{25973 \cdot (\pm 100)}{1,000,000} = \pm 2.6^\circ$$



ENGINEERING DESIGN DATA

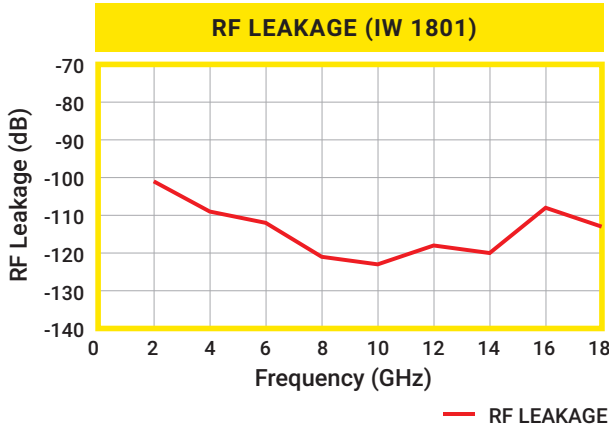

Measured values of IW 1801 cable using the test method specified in MIL-T-81490.

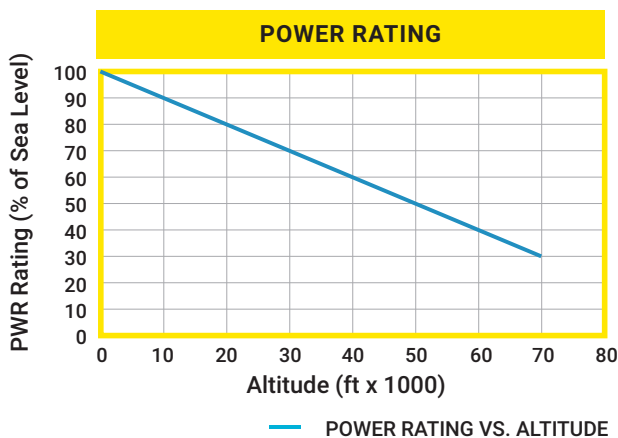
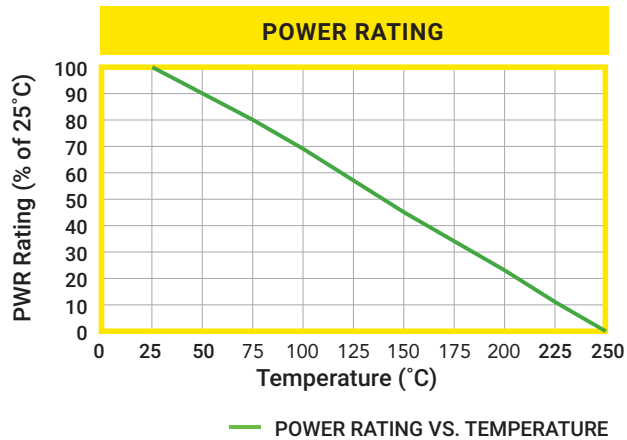

Insertion Loss vs. Temperature

$$dB_T = \alpha_{20} \sqrt{.0038 (T-20)} + 1$$

Use this equation to determine cable loss (dB) at any temperature (T) in degrees Celcius. α_{20} is the cable loss at 20°C

COAXIAL TRANSMISSION LINE EQUATIONS

Impedance (W)

$$Z_0 = \frac{138.059}{\sqrt{\epsilon}} \cdot \log_{10} \left(\frac{D}{d} \right)$$

Cut Off Frequency (GHz)

$$f_{co} = \frac{7.52}{\sqrt{\epsilon} \cdot (D + d)}$$

Velocity of Propogation (%)

$$V_p = \frac{100}{\sqrt{\epsilon}}$$

Outer Conductor Loss (dB)

$$A_c = \frac{2.745 \cdot 10^{-4}}{Z_0} \sqrt{\rho f} \left(\frac{K_o l}{D} \right)$$

Inner Conductor Loss (dB)

$$A_c = \frac{2.745 \cdot 10^{-4}}{Z_0} \sqrt{\rho f} \left(\frac{K_i l}{D} \right)$$

Dielectric Loss (dB)

$$A_d = (23.15 \cdot 10^{-10}) \cdot \sqrt{\epsilon} \cdot f \cdot \tan \delta \cdot l$$

Reflection Loss (dB)

$$A_r = 10 \log_{10} \left[\frac{(VSWR + 1)^2}{4(VSWR)} \right]$$

Time Delay (ns/ft)

$$TD = 1.016 \sqrt{\epsilon}$$

Capacitance (pf/ft)

$$C = \frac{1016 \sqrt{\epsilon}}{Z}$$

D = Inner diameter of outer conductor (inches)

d = Outer diameter of inner conductor (inches)

ϵ = Dielectric constant

ρ = Resistivity in Ohm-cm

f = Frequency in Hertz

l = Length in inches

Z₀ = Characteristic impedance

K_o = Outer conductor stranding factor

K_i = Inner conductor stranding factor

tan δ = Loss tangent of dielectric

CABLE HANDLING

The following contains a list of precautions and procedures that should be taken when handling or installing Insulated Wire cable assemblies. They should be used as guidelines and followed whenever possible. By doing this you can ensure a long assembly life which requires virtually no maintenance.

HANDLE CABLE WITH CARE

IW cable assemblies are designed to operate at the highest electrical performance level. High performance cables such as these require special handling procedures to ensure optimum electrical performance. Many of these handling procedures are outlined in detail, however taking just a few basic preventative measures during handling can significantly extend the life of the assembly. You should always take care to prevent anything from being placed on an assembly. This could result in internal damage caused by compression. Also, prevent the cable from bending below its minimum bend radius as this will cause the cable to kink, which results in internal damage and subsequent degradation in RF performance.

AVOID TORQUING DOWN CONNECTOR ENDS UNTIL BOTH CONNECTORS ARE MATED IN POSITION

It is important to first hand tighten both connectors into position before any torque is applied. If a connector is torqued down before the assembly is routed into position, excessive torsion could be applied at the torqued connector's termination during the routing. These torsion forces could cause the dielectric to change its mechanical position at the connector termination. This could ultimately lead to an electrical failure.

LIMIT BEND RADIUS WHENEVER POSSIBLE

Although IW cable assemblies can accommodate a very small bend radius, it is recommended to use the widest possible radius to fit the application. This will help to keep mechanical stresses low through the bend and prolong the life of the assembly.

AVOID TWISTING ASSEMBLY TO ORIENT CONNECTORS

When installing assemblies with right angle connectors, do not twist the cable or connectors to orient with the mating connectors. Twisting the assembly could result in mechanically changing the dielectric position at the termination and ultimately lead to an electrical failure. Assemblies should be purchased with a specific connector offset angle to match the proper mating connector. If an offset angle needs to be changed during assembly installation, proper adjustment procedures can be obtained by calling IW's Technical Support.

AVOID BENDING THE ASSEMBLY AT THE CONNECTOR TERMINATION

A cable assembly should never be bent at the back of the connector. Applying a bend prematurely at the end of an assembly and allowing the bend to encompass the connector could lead to the build up of excessive cable forces against the connector and through the bend area. The applied forces will cause the cable to kink. Electrical degradation and possible failure may result.

AVOID PULLING AN ASSEMBLY THROUGH CHANNELING BY THE CONNECTOR END TERMINATION

Never pull an assembly by its connector when routing it through a structure, channeling or building. Doing this could mechanically damage the connector termination. The assembly should always be pulled by the cable itself. Furthermore, the installation should be assisted by pushing the assembly through the channeling while the cable is pulled. Additionally, it is less stressful to the assembly if it is installed in phases (through individual sections) rather than a single run across the entire routing length.

NEVER ALLOW AN ASSEMBLY TO SUPPORT ITS OWN WEIGHT WHEN ROUTED IN A VERTICAL INSTALLATION

Never allow an assembly to hang freely by its own weight. Clamp down the cable at equal intervals along its length. Cable hangers can be used when it is not possible to clamp down the assembly in a vertical installation provided the assembly has been reinforced for such an installation. Using multiple hangers whenever possible is also recommended to help evenly distribute the assembly's weight along the run.

AVOID SUBJECTING THE CONNECTOR ENDS TO CABLE AXIAL LOADS

Cable assembly life can be increased by clamping down the cable a few inches from the connector ends in applications where the cable will be moving (such as a moving antenna) or where a high vibration condition exists. Clamping the cable down at the cable ends reduces mechanical loads applied to the connector when the cable is moved.

CABLE HANDLING

AVOID THE USE OF CABLE TIES

Most high performance cables use an air filled dielectric core. This makes the cable very soft. Therefore any compressive load applied to the cable has the potential of collapsing the dielectric core within the cable. Cable ties and tie wraps are not recommended for this reason. They offer virtually no load distribution and consequently focus very high compressive forces through the tied down area. A concentrated force such as this almost always deforms the cable and significantly degrades assembly performance. For best holding results with minimal clamping forces, IW recommends rubberized clamps. Be sure to select a clamp that will apply a minimum amount of compression force while still offering the desired holding strength. Selecting a clamp that is too small can do as much damage to an assembly as a cable tie.

ALWAYS WRAP CONNECTORS IN WEATHER PROOFING WHEN INSTALLING OUTSIDE

All cable connections that will be subjected to rain and snow should be wrapped in a weather proofing material. A self fusing silicone tape is recommended to create a weather tight seal over the connection. If weather precautions are not taken, water will eventually work its way into the connector assembly causing high insertion losses.

ALWAYS PROVIDE ADEQUATE DRIP LOOPS

Always allow for a drip loop in outside applications to prevent water from flowing down the cable and onto the connector. Over time the water could work its way into the connector assembly causing high insertion losses.

TAKE EXTRA CARE ON SHORT ASSEMBLIES

- Always bend assemblies around mandrels whenever possible.
- The use of mandrels or wheels will help to evenly distribute bending loads applied to the cable. This is the preferred method for bending cables.
- Take caution when bending cables by hand.
- Sometimes bending a cable by hand is the only option. In this case the following method should be used:
 - Start at bending point keeping hands close together.
 - Bend the cable a little at a time working in an outward direction along the bend.
 - Return to the center point of the bend and work in an outward direction making the bend a little tighter.
- Continue to return to the center of the bend, and working outward until the desired bend is reached.

TAKE CAUTION BENDING CABLES UNDER 12" IN LENGTH

An assembly that is 12" in length and smaller can be very rigid depending on the cable type. The cable becomes rigid because its inner and outer conductors are fully (mechanically) terminated to the cable connectors.

The cable is terminated this way to yield maximum electrical performance. Unfortunately, it minimizes the bending characteristics of the assembly because the cable is too short to accommodate the total material volume displacement needed for a typical bend. Often, the minimum bend radius can not be achieved without damaging the assembly. Therefore, short cables should only be used in applications where slight jogging bends will be used. A longer assembly that uses a service loop should be considered as a replacement for a short cable in situation where a tight or sharp bend is needed.



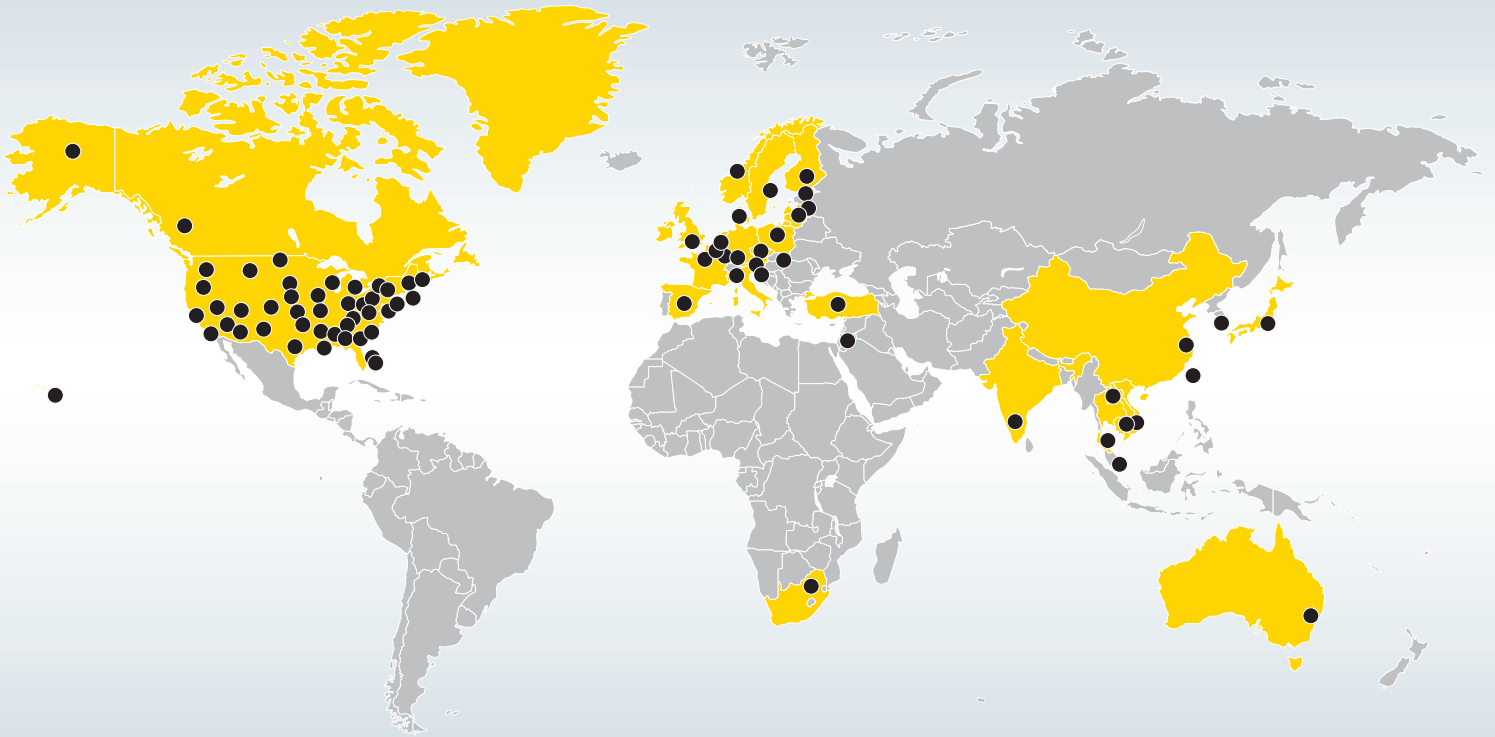

Contact us to find out where your nearest
local IW representative is located



www.insulatedwire.com



INSULATED WIRE
INCORPORATED

INSULATED WIRE INC

960 Sylvan Avenue,
Bayport, NY 11705

t +1 631-472-4070

e nysales@insulatedwire.com

www.insulatedwire.com

Visit our website for contact information on your local representative.

Please don't hesitate to contact IW directly if you are unable to locate a representative in your area.