

2.9mm Design Specifications

General

Materials:	SST, Corrosion-resistant, Non-magnetic 303, per ASTM A484 & A582. Beryllium Copper per ASTM-B-196, QQ-C-530, Oxide-noryl™, MIL-P-46129
Finish:	Center contacts and solder components shall be plated per MIL-G-45204 Type II, Class I over Nickel plate per QQ-N-290, Body & Body components shall be passivated per ASTM A380
Compatibility:	Mechanically compatible with 3.5mm and SMA connectors.

Electrical Frequency:

DC-40 GHz

Nominal Impedance:

50 Ohms

Temperature Rating:

-55° C to 100° C

Mechanical

Connector Durability:

500 cycles minimum

Contact Torque:

4.0 inch-ounces minimum

Coupling nut mating torque: 8-10 inch lbs.

Environmental

Corrosion (salt spray):

MIL-STD-202, method 101, test condition B 5% salt solution

Vibration High Frequency:

MIL-STD-202, method 204, test condition D (20 G's)

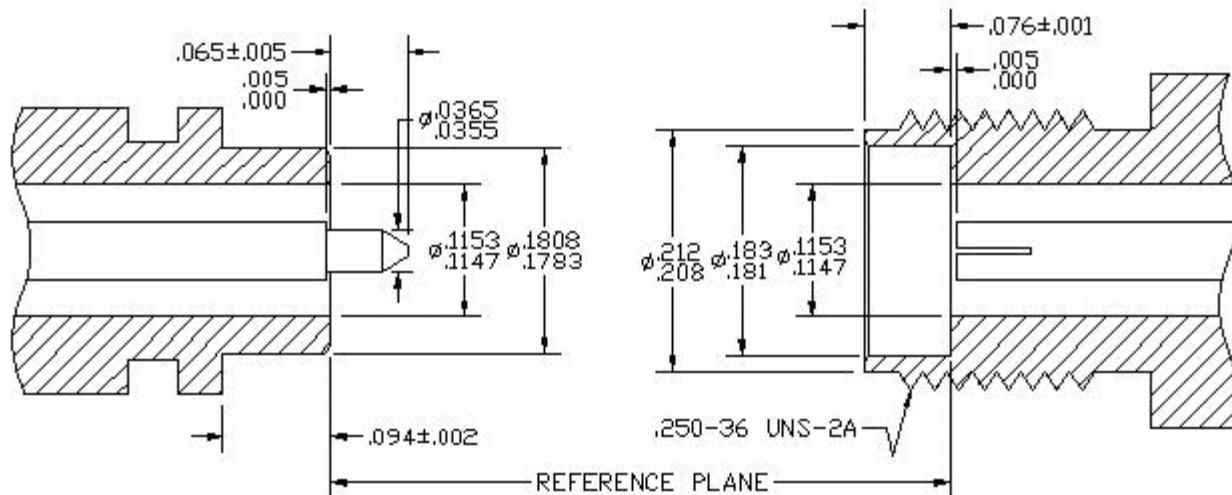

25-925-2000-90

2.9mm Jack to 2.9mm Jack
Bulkhead Mount

DC-40 GHz

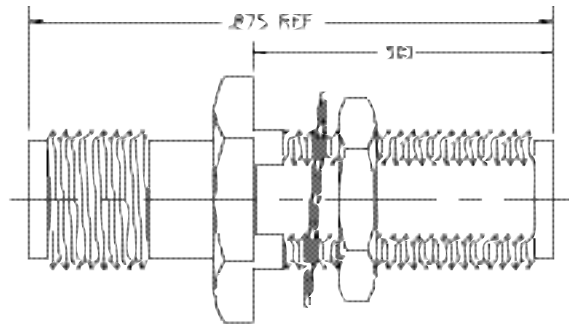
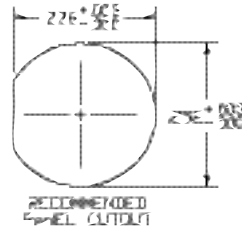

25-925-3500-90

2.9mm Jack to 2.9mm Jack
Bulkhead Mount

DC-40 GHz

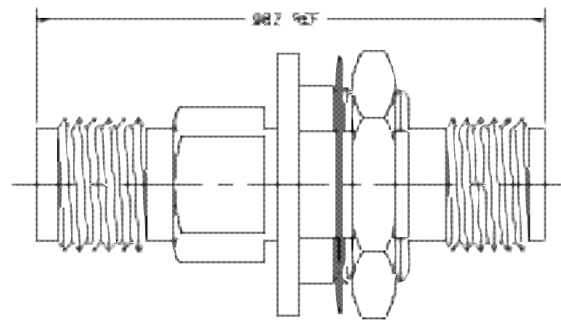
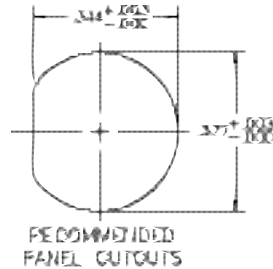

25-925-4010-90

2.9mm Jack to 2.9mm Jack
4 Hole Flange Mount

DC-40 GHz

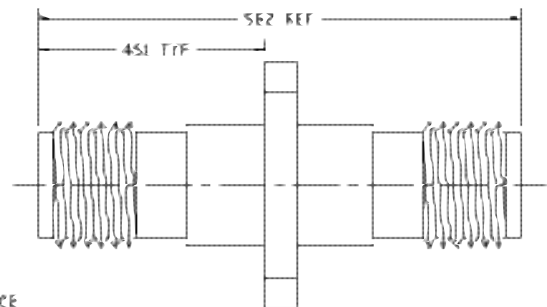
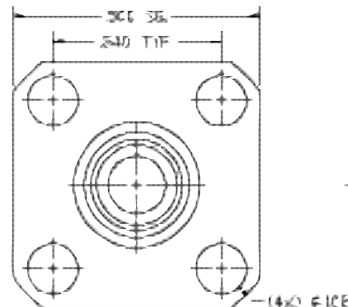

24-925-2010-90

2.9mm Plug to 2.9mm Jack R/A

DC-40 GHz

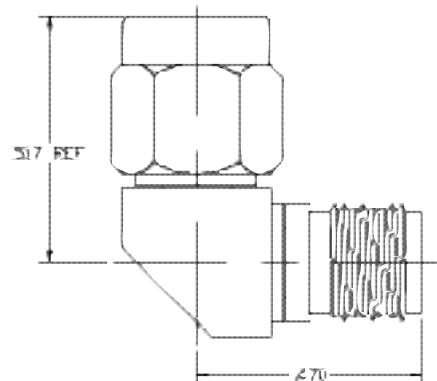

2.9mm In-Series Adapters

24-925-0000-90

2.9mm Plug to 2.9mm Jack

DC-40 GHz

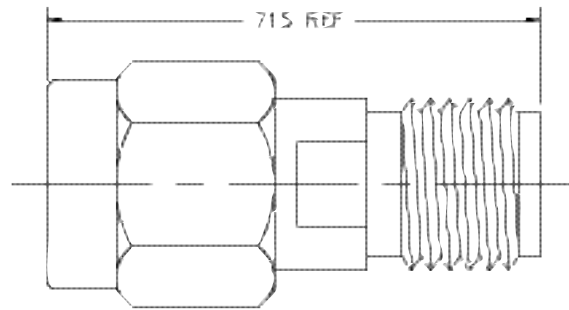
**25-925-0000-90**

2.9mm Jack to 2.9mm Jack

DC-40 GHz

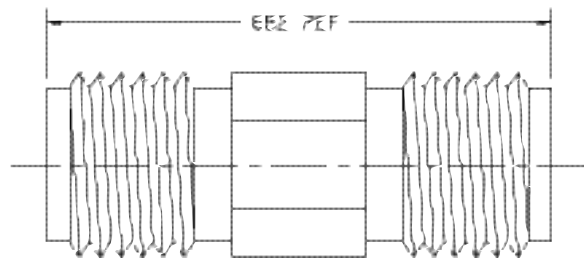
**24-924-0000-90**

2.9mm Plug to 2.9mm Plug

DC-40 GHz

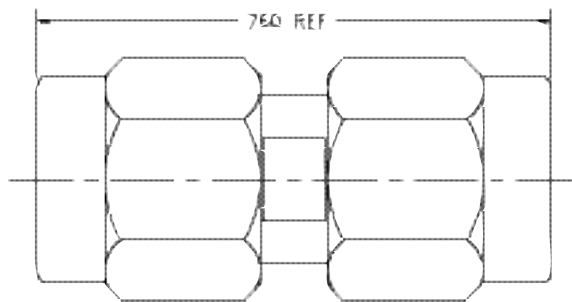
**24-924-2010-90**

2.9mm Plug to 2.9mm Plug R/A

DC-40 GHz

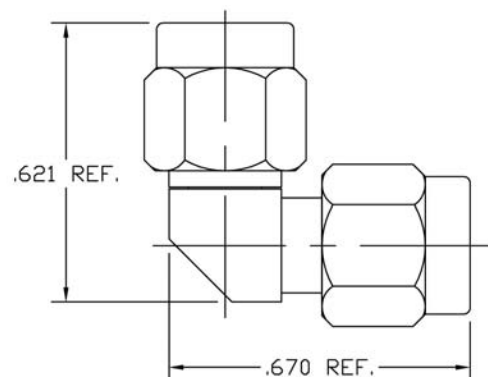

24-925-3100-90

2.9mm Plug to 2.9mm Jack
4 Hole Flange Mount

DC-40 GHz

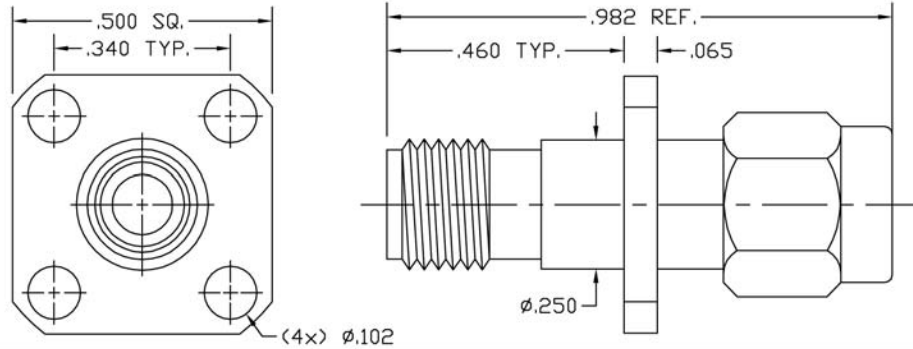

25-925-2000-91

2.9mm Jack to 2.9mm Jack
Bulkhead Mount
(No O-Ring)

DC-40 GHz

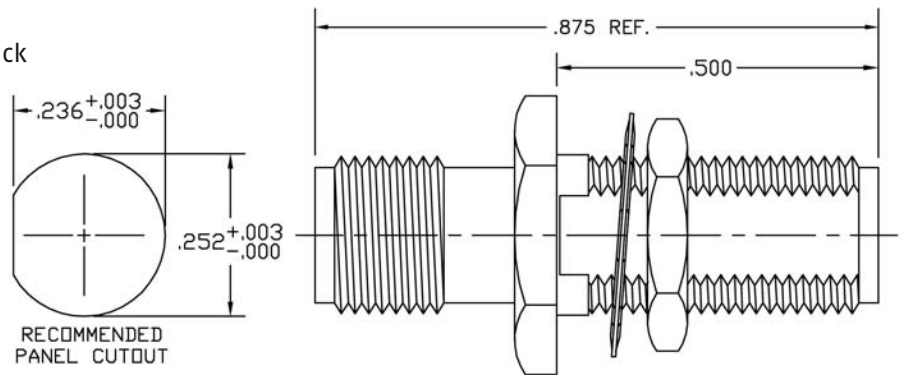

25-925-2000-92

2.9mm Jack to 2.9mm Jack
Bulkhead Mount

DC-32 GHz

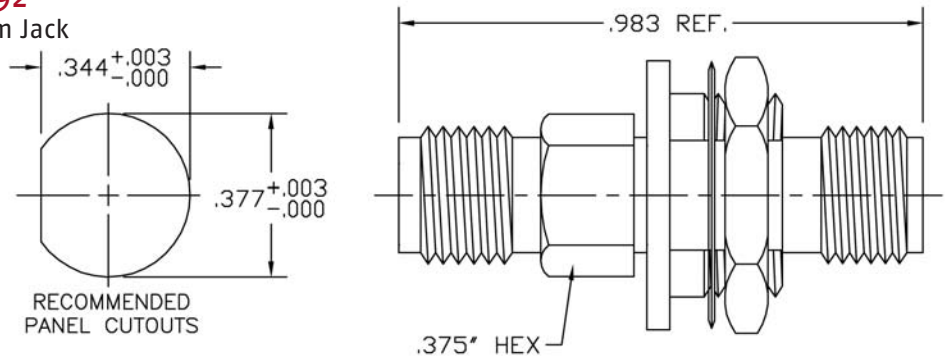

25-925-2000-93

2.9mm Jack to 2.9mm Jack
Bulkhead Mount

DC-40 GHz

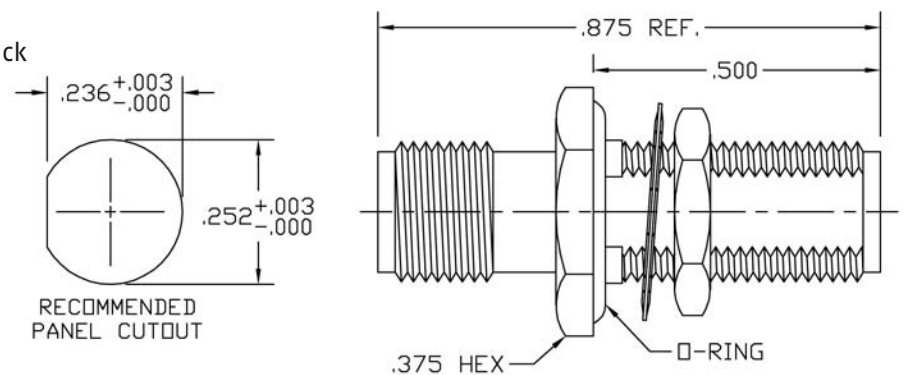

2.9mm In-Series Adapters



25-925-2010-90

2.9mm Jack to 2.9mm Jack R/A

DC-40 GHz

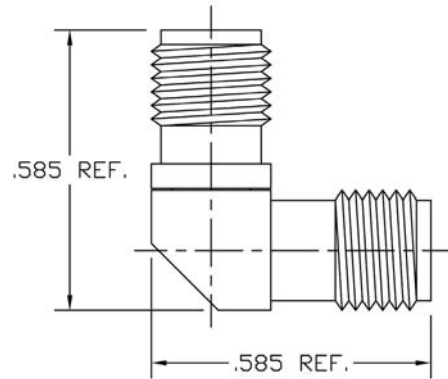

25-925-2040-90

2.9mm Jack to 2.9mm Jack
Hermetic Bulkhead

DC-40 GHz

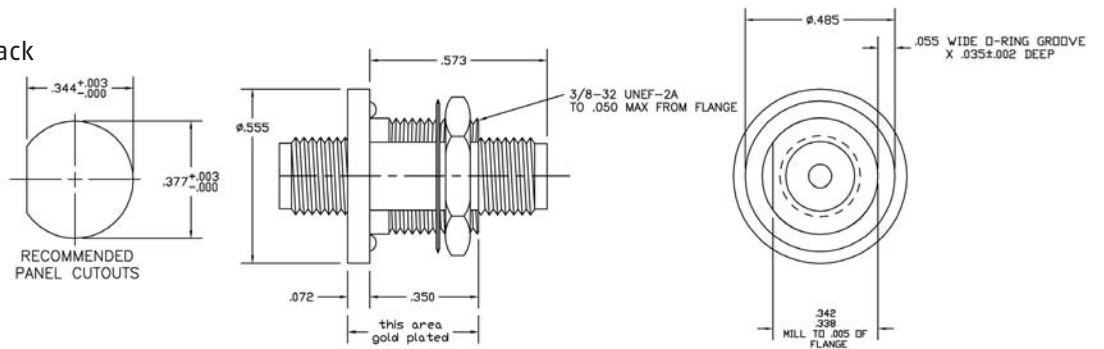

2.9mm Cable Connectors

25-000-1585-90

2.9mm Jack to .085 S/R Cable
Solder Clamp

DC-40 GHz

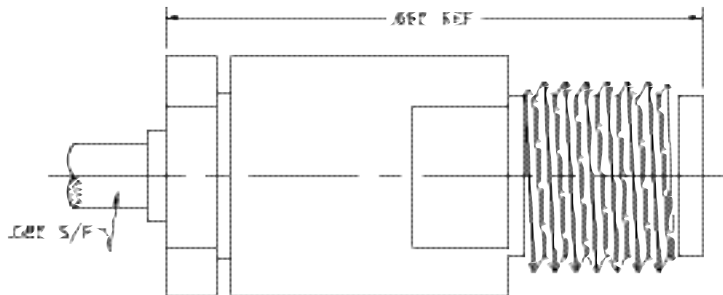

25-000-1541-90

2.9mm Jack to .141 S/R Cable
Solder Clamp

DC-40 GHz

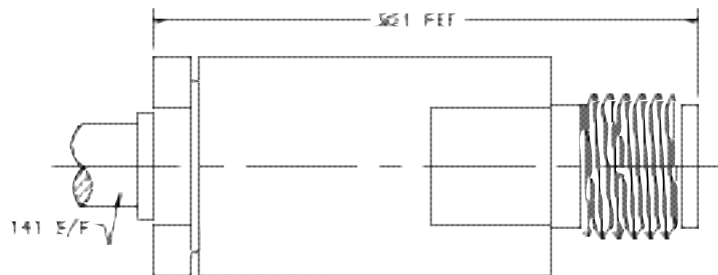

24-000-1085-90

2.9mm Plug to .085 S/R Cable
Direct Solder

DC-40 GHz

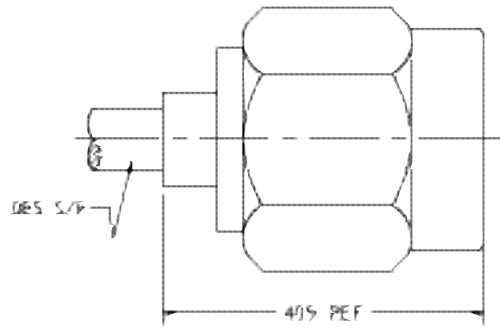

24-000-1041-90

2.9mm Plug to .141 S/R Cable
Direct Solder

DC-40 GHz

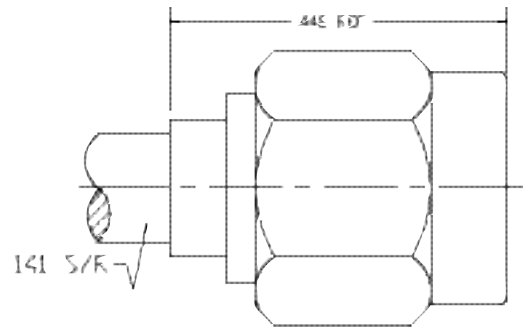

24-000-1012-90

2.9mm Plug to UT120 Low Loss
Direct Solder

DC-40 GHz

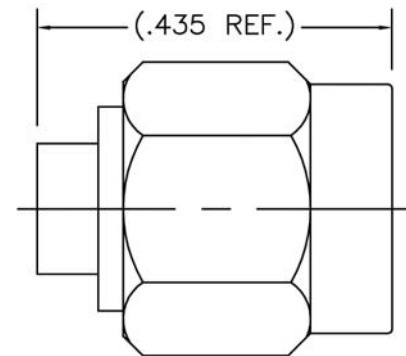

24-000-1501-90

2.9mm Plug to IW1501
Solder Clamp

DC-40 GHz

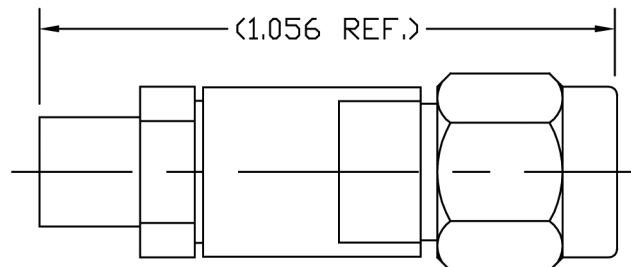

24-000-1503-90

2.9mm Plug to IW1503
Solder Clamp

DC-40 GHz

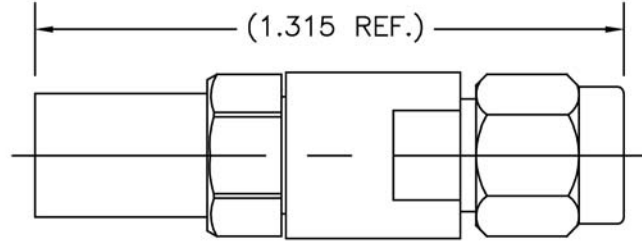

24-000-1516-90

2.9mm Plug to SFT-316
Solder Clamp

DC-40 GHz

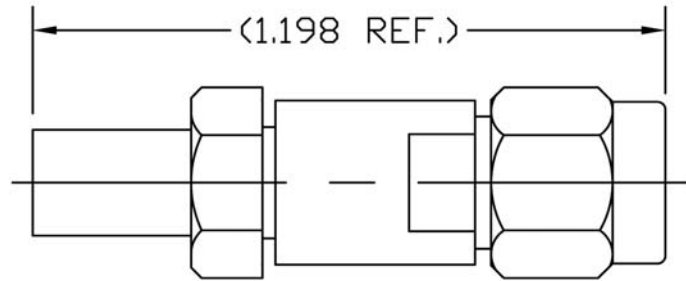

24-000-1523-0

0
2.9mm Plug to LL120
Solder Clamp

DC-40 GHz

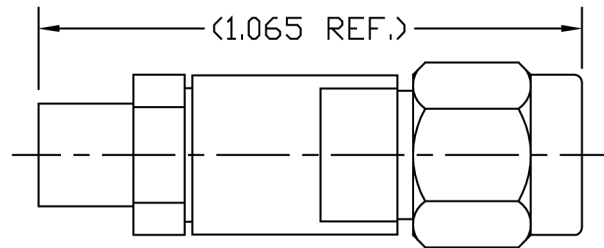

24-000-1541-90

2.9mm Plug to .141 S/R
Solder Clamp

DC-34 GHz

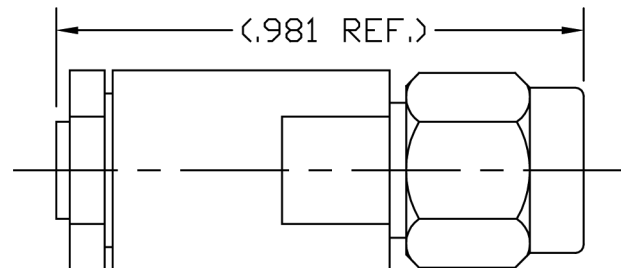

24-000-1547-80

2.9mm Plug to .047 S/R
Solder Clamp

DC-40 GHz

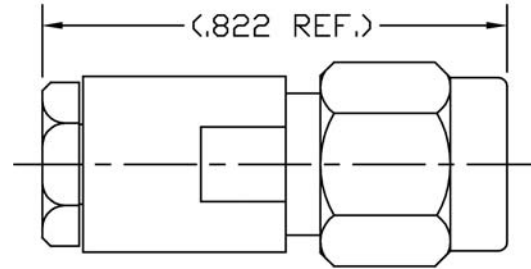

24-000-1563-9

0

2.9mm Plug to HP160
Solder Clamp

DC-40 GHz

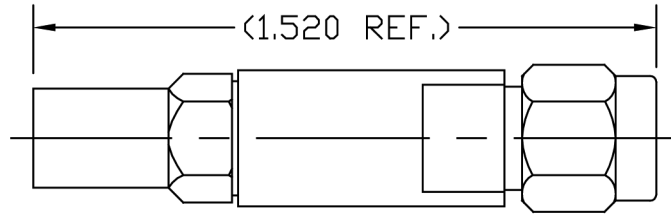

24-000-1585-90

2.9mm Plug to .085 S/R
Solder Clamp

DC-40 GHz

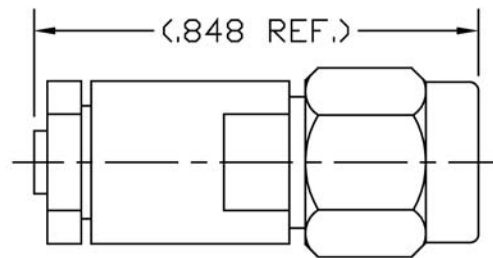

24-000-1597-9

0

2.9mm Plug to LL142
Solder Clamp

DC-40 GHz

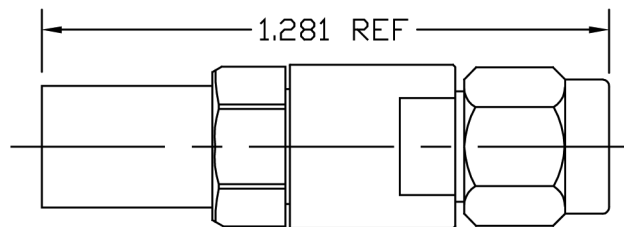

2.9mm Cable Connectors

24-041-1501-902.9mm Plug R/A to IW1501
Solder Clamp

DC-40 GHz

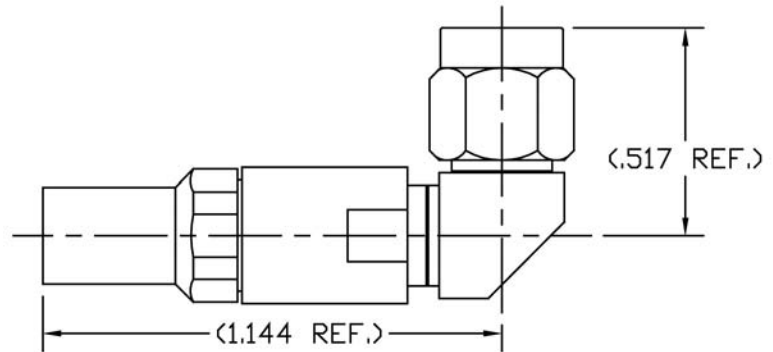
**24-041-1562-90**2.9mm Plug R/A to Lab-Flex 162
Solder Clamp

DC-40 GHz

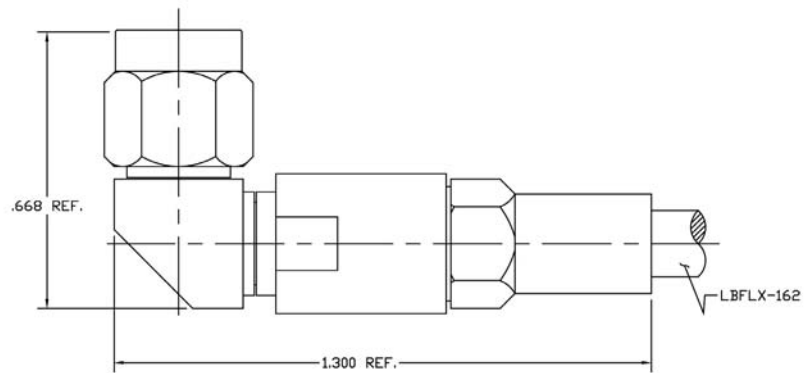
**24-041-1597-90**2.9mm Plug R/A to LL142
Solder Clamp

DC-40 GHz

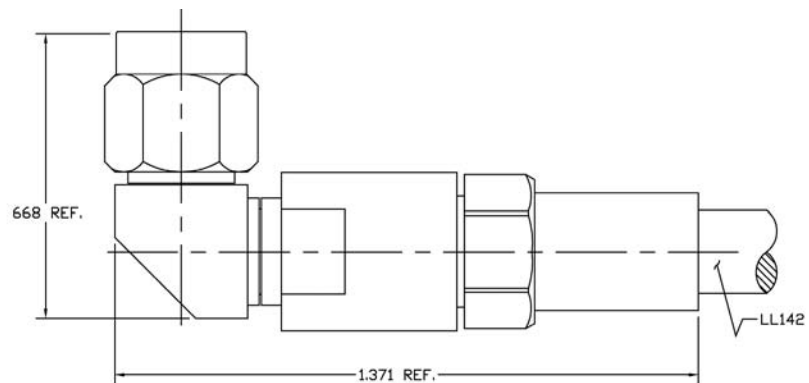
**25-000-1508-90**2.9mm Jack to .085 Low Loss
Solder Clamp

DC-40 GHz

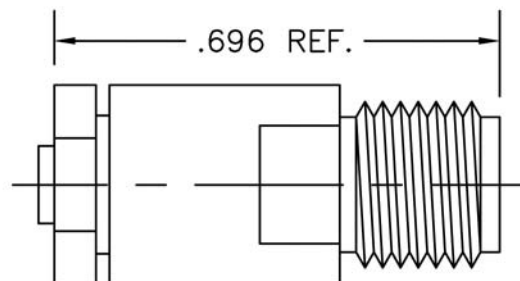

2.9mm Cable Connectors

25-020-1563-90

2.9mm Jack Bulkhead to HP160
Solder Clamp
DC-40 GHz

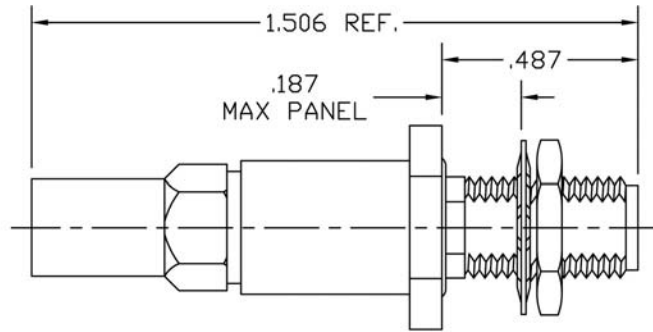
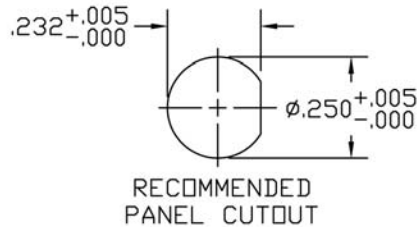

25-020-1585-90

2.9mm Jack Bulkhead to .085 S/R
Solder Clamp
DC-40 GHz

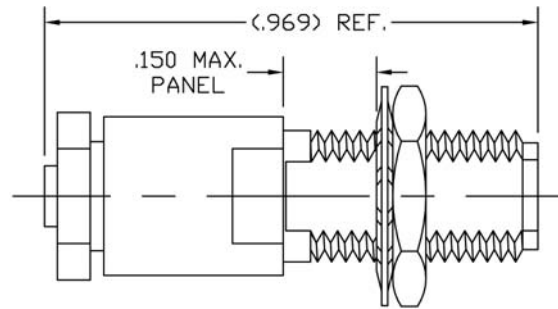
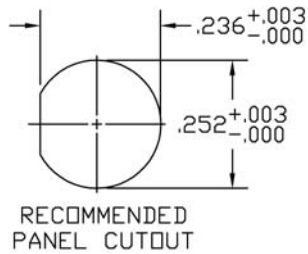

2.9mm Receptacles

25-145-1510-12

2.9mm Jack Receptacle
(Sparkplug)

DC-40 GHz

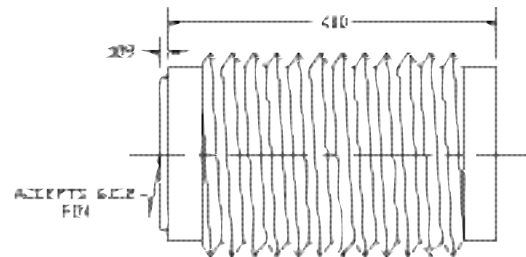

24-145-1510-12

2.9mm Plug Receptacle
(Sparkplug)

DC-40 GHz

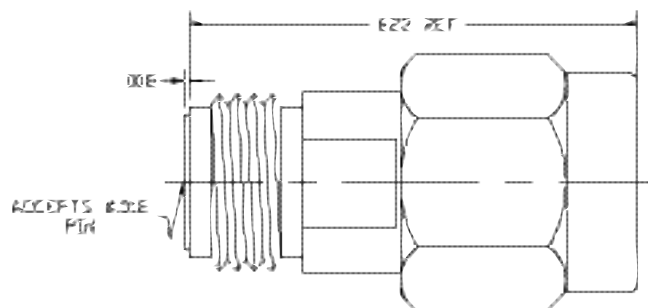

2.9mm Receptacles

25-130-1500-90

2.9mm Jack Receptacle
2 Hole Flange Mount

DC-40 GHz

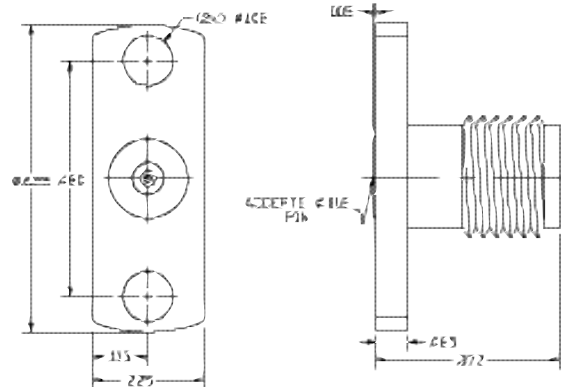

25-131-1500-90

2.9mm Jack Receptacle
4 Hole Flange Mount

DC-40 GHz

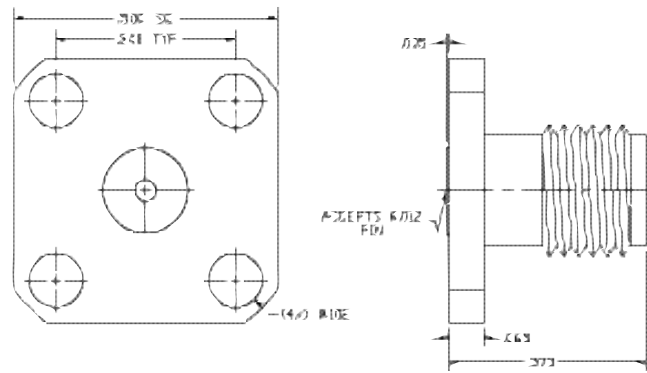

24-130-1500-90

2.9mm Plug Receptacle
2 Hole Flange Mount

DC-40 GHz

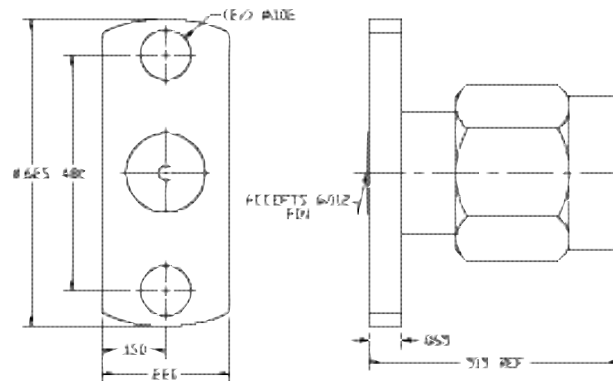

24-131-1500-90

2.9mm Plug Receptacle
4 Hole Flange Mount

DC-40 GHz

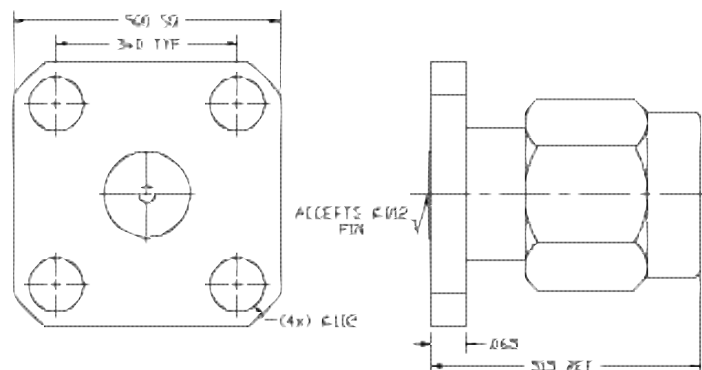

24-130-1000-90
2.9mm Plug Receptacle
2 Hole Flange Mount

DC-40 GHz

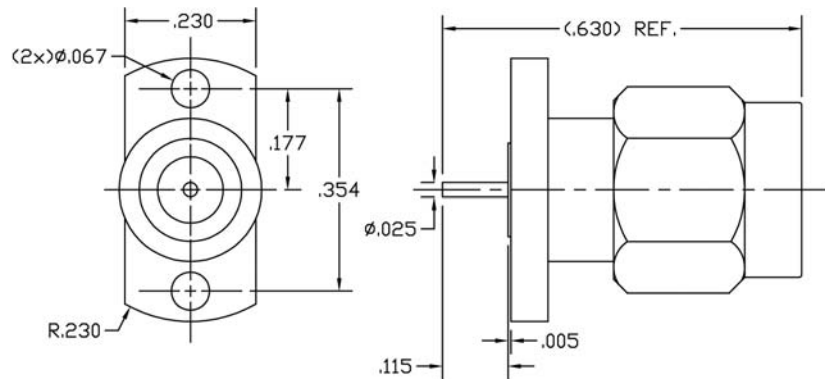

24-131-1000-90
2.9mm Plug Receptacle
4 Hole Flange Mount

DC-40 GHz

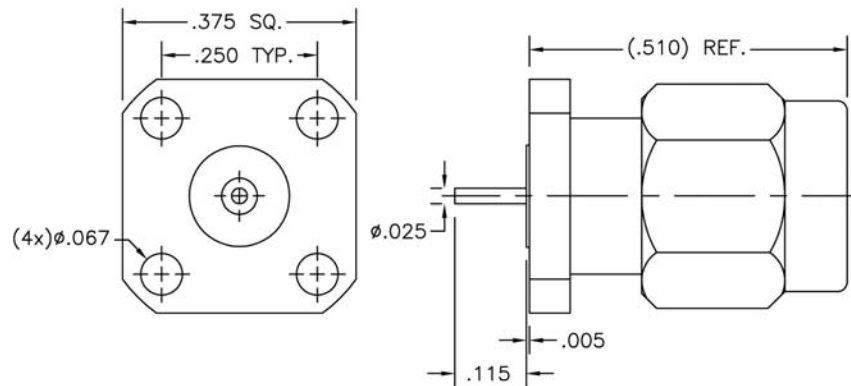

25-131-1000-96
2.9mm Jack Receptacle
4 Hole Flange Mount

DC-40 GHz

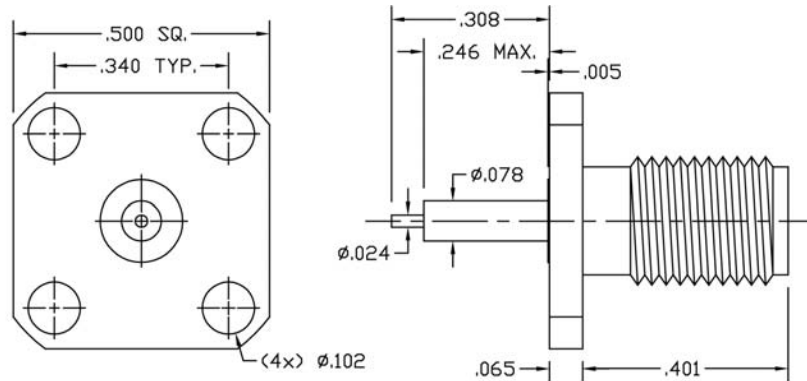

25-146-1000-90
2.9mm Jack PCB Mount

DC-40 GHz

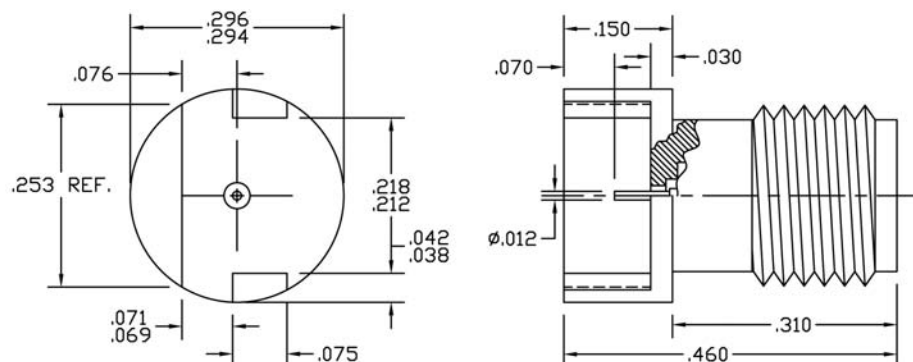

2.9mm Receptacles

25-131-1500-92
 2.9mm Jack Receptacle 4
 Hole Flange Mount
 Accepts .020 Diameter Pin

DC-40 GHz

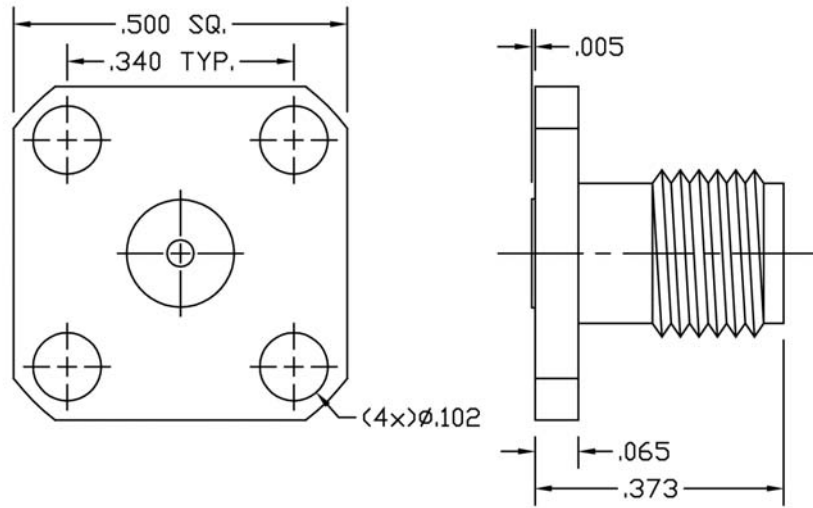

25-130-1000-90
 2.9mm Jack Receptacle
 2 Hole Flange Mount

DC-40 GHz

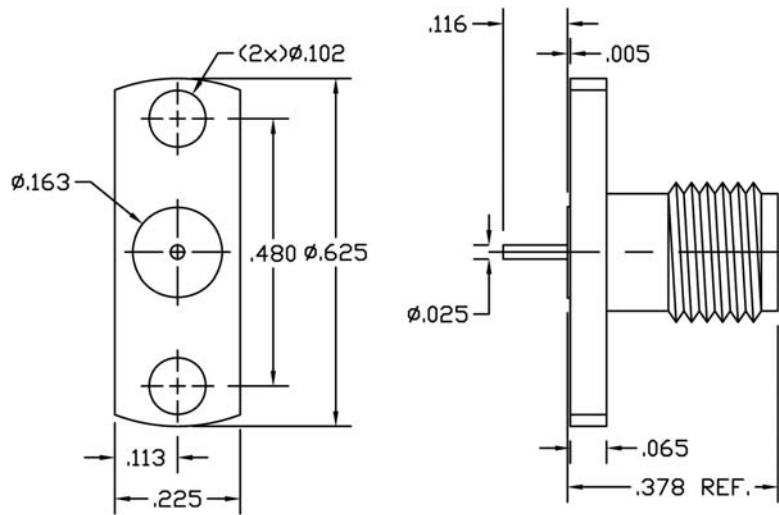

25-146-1000-92
 2.9mm Jack PCB Mount

DC-50 GHz

